

IWAKI Magnetic Drive Pump

MDM Series (ISO Version)

Instruction Manual

 Read this manual before use of product

Thank you for selecting IWAKI Magnetic Drive Pump MDM Series. This instruction manual, which is divided into five sections, namely "Safety", "Outline of Product", "Installation", "Operation" and "Maintenance", deals with the correct handling and operation procedures for the pump. To make maximum use of the pump and to ensure safe and long time operation of the pump, please read this manual thoroughly and carefully prior to operating the pump.

Contents



SAFETY SECTION	1
OUTLINE OF PRODUCT	4
1. Unpacking and inspection.....	5
2. Model code.....	6
3. Conditions to be used.....	7
4. Structure and names of parts.....	8
INSTALLATION	9
5. Installation.....	10
6. Piping.....	11
7. Electrical wiring.....	13
OPERATION	14
8. Precautions on operation.....	15
9. Operation.....	16
10. Pump stopping.....	16
MAINTENANCE	17
11. Trouble shooting.....	18
12. Maintenance & inspection.....	20
13. Disassembling & assembling.....	21
14. Repair parts list.....	27
15. Mass of pump.....	35

SAFETY SECTION



For the Safe and Correct Handling of the Pump

- Before use of the pump, read carefully this "Safety Section" to prevent accidents and to avoid the damage or loss of other assets.
- Observe and abide by the instructions described in this "Safety Section". These instructions are very important for protecting pump users or other persons from hazard or from loss of assets.
- Meaning of symbols







Following two symbols describe the extent of hazards and loss which may brought if the instructions are not observed or if the pump is wrongly used.

 Warning	Nonobservance or misapplication of the contents of the "Warning" could lead to a death or heavy injury of person.
 Caution	Nonobservance or misapplication of the contents of the "Caution" could lead to an injury of person or damage of assets.









Following two symbols describe the content to be observed.

	Prohibited action or procedure is indicated. Inside or near this circle, a concrete activity to be prohibited is depicted.
	Action or procedure which must be performed without fail is indicated. Inside this circle, a concrete activity to be performed is depicted.

Safety Section

 Warning	
<ul style="list-style-type: none"> Magnet field danger The magnet drive pumps contain very strong magnets. The strong magnet field could adversely affect persons who are assisted by electronic devices such as pacemakers etc. 	
<ul style="list-style-type: none"> Always turn off power supply prior to maintenance works etc. Pay special attention so that no other operator turns on by mistake the power supply while someone is working on the pump. In a noisy or poor visibility environment, display a sign near power supply switch to notify other person that someone is "WORKING" on the pump. Power supply mistakenly turned on during maintenance works may lead to personal injury. Each operator must pay special attention. 	 Power off
<ul style="list-style-type: none"> Wear protectors When piping is removed or pump is disassembled/assembled, wear protective gear such as safety goggles and protective gloves etc. 	 Wear protective gear
<ul style="list-style-type: none"> Lifting pump When pump is lifted, apply chain or belt to eye bolt and motor to keep the pump & motor horizontally. 	
<ul style="list-style-type: none"> No remodeling Remodeling of pump may result in serious personal injury or damage of the pump. Do not attempt remodeling pump because it is very dangerous. 	 No Remodeling
<ul style="list-style-type: none"> Dangerous liquid When the pump is used to transfer dangerous liquids mentioned as below, the pump must always be checked and watched so that the liquid can not be leaked. The operation of pump leaking the liquid may result in personal injury, explosion or fire accident. <ul style="list-style-type: none"> Explosive or flammable liquids Corrosive or stimulus toxic liquids Liquids harmful to human health 	

Safety Section

 CAUTION	
<ul style="list-style-type: none"> Attention to magnetic force This pump employs strong magnets. Special attention must be paid not to be injured by attracting force of magnets. Follow the procedure "Disassembling and Assembling" when the maintenance works are done. 	
<ul style="list-style-type: none"> Do not run pump dry Do not run pump dry (without liquid). If the pump run dry, heat is generated by rubbing, which causes pump damage. If the pump is operated with suction side valve closed, the pump runs dry. 	 Do not run dry
<ul style="list-style-type: none"> Countermeasures for static electricity When low electric conductivity liquid such as ultra-pure water and fluor inactive liquid (e.g. Fluorinert™) are handled, the static electricity may be generated in the pump, which may cause static discharge and pump break down. Take countermeasures to avoid and remove the static electricity. 	
<ul style="list-style-type: none"> Qualified operator The pump must be handled or operated by the person who has enough knowledge and well acquainted with the pump. 	
<ul style="list-style-type: none"> For specified application only The use of pump in any application other than those clearly specified may result in the failure or damage of the pump. 	
<ul style="list-style-type: none"> Ventilate the site When handling the liquid which may generate toxic gas, safety measures such as ventilation must be taken to prepare for the accidental liquid leakage. 	
<ul style="list-style-type: none"> Countermeasure to liquid flowing out Protective measurement must be taken against liquid flowing out caused by damage of pump or pipe by accident. Also, appropriate measurement must be taken so that the liquid can not directly flow out on the ground. 	
<ul style="list-style-type: none"> Disposal of used pump Disposal of used or damaged pump must be done in accordance with local laws and regulations. (Consult a licensed industrial waste products disposing company.) 	

OUTLINE OF PRODUCT

<i>1. Unpacking and inspection</i>	<i>5</i>
<i>2. Model code.....</i>	<i>6</i>
<i>3. Conditions to be used.....</i>	<i>7</i>
<i>4. Structure and names of parts.....</i>	<i>8</i>

1. Unpacking and inspection

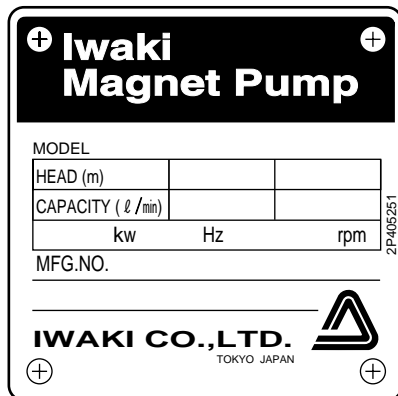

After unpacking of the pump, check the following points.

- (1) If the product is ordered one.
Check model code, discharge capacity, discharge pressure, voltage which are written on nameplate of pump and motor to see if they conform to your order.
- (2) If the product is not damaged or bolts are not loosened during transportation.
- (3) If accessories are attached.
Standard accessories:
Bolts for back pull-out M12 × 100: 2pcs
(M10 × 50 : 2pcs for MDM25-1)
Optional accessories if ordered

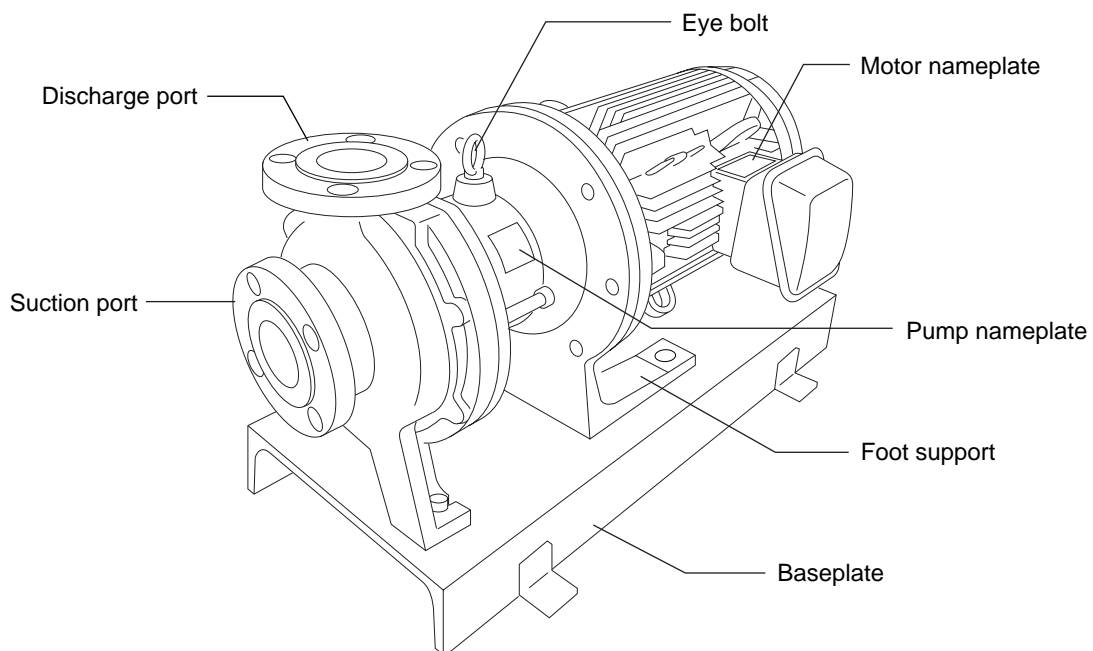

2. Model code

MDM50 - 150 1 E KK F 075 I - D 2

① ② ③ ④ ⑤ ⑥ ⑦ ⑧ ⑨ ⑩

- ① Pump discharge bore Suction Discharge
 25: 40 × 25
 32: 50 × 32
 40: 65 × 40
 50: 80 × 50
- ② Nominal impeller diameter: 110 - 195 (mm)
- ③ Impeller range: 1: Low head impeller type 2: High head impeller type (Available for MDM25 only)
- ④ Casing material: E: CFR-ETFE P: PFA
- ⑤ Bearing/spindle material: KK:SiC/SiC CF:High density carbon/High purity ceramic
- ⑥ Type of motor to be mounted: F : Flange mounted motor type
- ⑦ Motor output: 015 : 1.5 kW, 022 : 2.2 kW, 040 : 4.0 kW, 055 : 5.5 kW
 075 : 7.5 kW, 110 : 11 kW
- ⑧ Standard for connection flange/motor
 I : ISO flange + IEC motor J : JIS flange + JIS motor
- ⑨ Drain/special version

	Drain	Baseplate	Standard or Special version
A	Without drain	With baseplate	Standard
S			Special version
D	With drain		Standard
X			Special version
B	Without drain	Without baseplate	Standard
Y			Special version
E	With drain		Standard
Z			Special version

Note: For PFA material type, air vent is always equipped for "with drain" type.

- ⑩ Motor pole : 2 : 2 pole motor

3. Conditions to be used

1. Permissible pressure

Permissible pressure of the pump is 1 MPa. Pay attention so that the pump discharge pressure does not exceed this figure.

2. Slurry containing liquid

Basically slurry containing liquid can not be handled but SiC bearing type (KK type) can handle it in the following conditions:

- Slurry concentration up to 5 wt%
- Slurry hardness up to 80 Hs
- Slurry size up to 50 μm

3. Performance change caused by specific gravity and viscosity of liquid

When specific gravity and viscosity are larger than water, shaft power, discharge capacity and discharge head will change depending on specific gravity and viscosity of pumped liquid. The pump was made and shipped according to the information given to IWAKI. If the liquid condition is changed, ask and confirm IWAKI to use the pump without problem.

4. Influence by liquid temperature

The chemical liquid changes its viscosity, vapor pressure and corrosivity according to the temperature change. Pay attention to the change of liquid characteristics.

Liquid temperature range: ETFE material type	0 - 105 deg. C
PFA material type	0 - 120 deg. C
Ambient temperature range: 0 - 40 deg. C	
Ambient humidity range: 35 - 85% RH	

Note: For temperature range of each chemical liquid, refer to Chemical Resistant Table on booklet "Technical Information on MDM Series".

4. Structure and names of parts

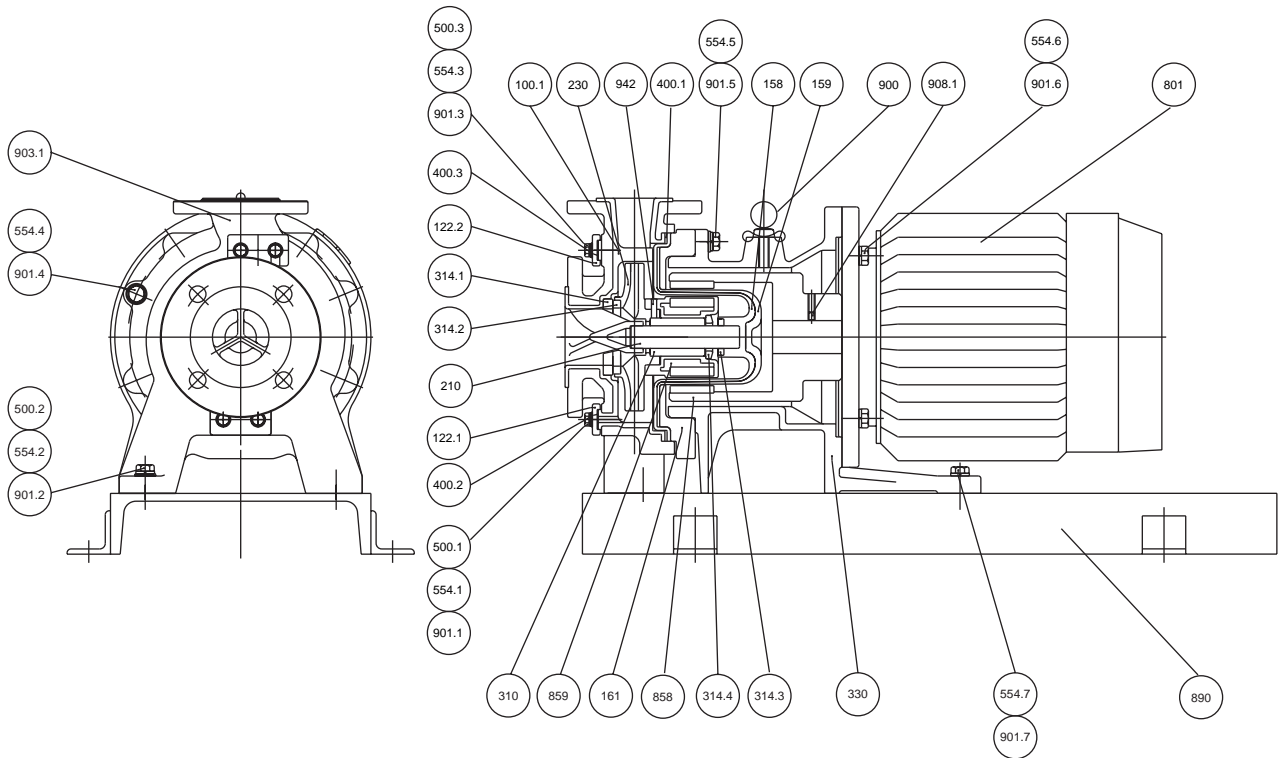

NO.	Parts name	Q'ty	NO.	Parts name	Q'ty
100.1	Front casing	1	554.2	Spring washer	2
100.2	Cover	1	554.3	Spring washer	2
122.1	Drain plate	1	554.4	Spring washer	8 (6) Note
122.2	Air vent plate	1	554.5	Spring washer	4
158	Rear casing	1	554.6	Spring washer	4
159	Rear casing cover	1	554.7	Spring washer	2
161	Rear casing support	1	801	Motor	1
210	Spindle	1	858	Drive magnet unit	1
230	Impeller	1	859	Magnet capsule unit	1
310	Bearing	1	890	Base plate	1
314.1	Liner ling	1	900	Eye bolt	1
314.2	Mouth ring	1	901.1	Hex. head bolt	2
314.3	Rear thrust	1	901.2	Hex. head bolt	2
314.4	Rear ring	1	901.3	Hex. head bolt	2
330	Foot support	1	901.4	Hex. head bolt	8 (6) Note
400.1	Gasket	1	901.5	Hex. head bolt	4
400.2	Drain gasket	1	901.6	Hex. head bolt	4
400.3	Air vent gasket	1	901.7	Hex. head bolt	2
500.1	Plain washer	2	903.1	Hex. head bolt	5
500.2	Plain washer	2	908.1	Hex. socket head bolt	2
500.3	Plain washer	2	942	Impeller pin	2
554.1	Spring washer	2			

Note: Q'ty in parenthese is for MDM25-1 (low head type)

INSTALLATION

<i>5. Installation</i>	10
<i>6. Piping</i>	11
<i>7. Electrical wiring</i>	13

5. Installation

Example of recommended piping

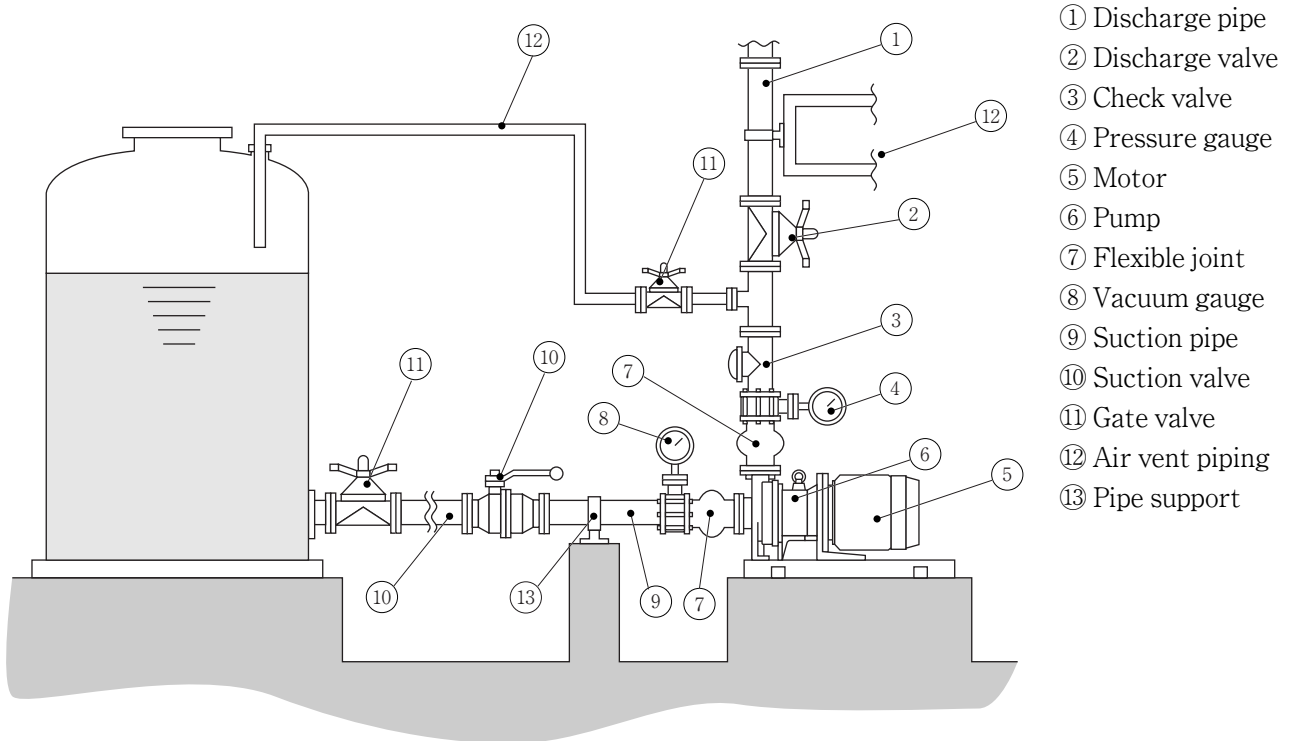

1. Installed position

- Install and fix the pump on the foundation which is not affected by vibration generated by other machines.
- Keep enough space around the pump for the back pull-out of motor, assembly and disassembly of the pump.
- Foundation area must be larger than pump base plate.

2. Location

- Install the pump as close to the tank as possible and at lower position than the tank (flooded suction).
- If the pump is installed at the location that the pump suction port comes higher position than the liquid level of tank (suction lift style), install the priming piping and foot valve at the end.

3. Foundation

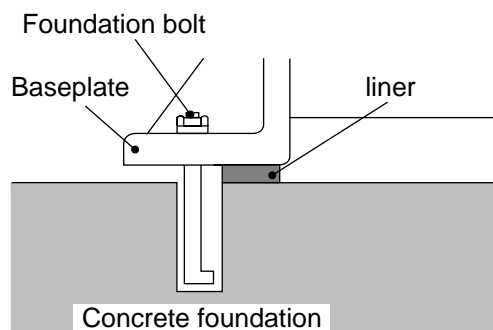

6. Piping

1. Tightening of pipe flange

Table below shows the bolt size and tightening torque for the connection of pipe flange to pump flange. Tightening torque is the figure when metallic flange and rubber gasket are used.

Bolt size	Tightening torque
M16	78.4 N · m

2. Pipe load and moment

Pipe load and moment put on the pump should not exceed the figures shown below.

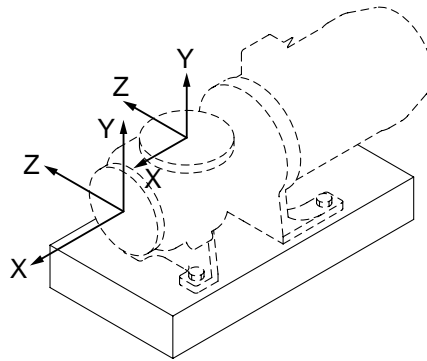

Allowable pipe load on pump flange

Direction of load	Load kN			
	Discharge flange		Suction flange	
	MDM25, 32, 40	MDM50	MDM25, 32, 40	MDM50
F _x	0.71	1.07	0.89	1.33
F _y (Pression/Tension)	0.89/0.44	1.33/0.67	0.58	0.89
F _z	0.58	0.89	0.71	1.07

Allowable moment on pump flange

Direction of load	Moment kN · m			
	Discharge flange		Suction flange	
	MDM25, 32, 40	MDM50	MDM25, 32, 40	MDM50
M _x	0.35	0.72	0.46	0.95
M _y	0.46	0.95	0.35	0.72
M _z	0.23	0.47	0.23	0.47

3. Suction piping

(1) Flooded suction

Flooded suction is recommended.

(2) Pipe diameter

Pipe diameter should be larger than pump inlet bore.

(3) Shortest piping

Employ less bends and shortest piping length.

(4) Straight piping

Employ straight pipe just before pump inlet port.

Pump inlet bore 50A or smaller : Straight pipe of 500 mm or longer

Pump inlet bore 65A or larger : Straight pipe of 8 times as larger than inlet port

(5) Air pocket in piping

Do not allow any projection in piping where air may be trapped along the suction pipe.

Suction pipe should have an ascending gradient of 1/100 toward the pump.

(6) Different diameter of pipes

If diameter of pump suction port is different from that of suction pipe, use the eccentric reducer pipe. Connect the eccentric reducer pipe so that upper side is level. Residual air may not go out if it is mounted in reverse.

(7) Gate valve in suction side

In case of flooded suction, install gate valve in suction piping. It is needed when the pump is disassembled and inspected.

(8) Piping for flushing

Install pump flushing piping in case that the dangerous liquid will be handled.

(9) End of suction piping

The end of suction pipe always should be located 500 mm or more below the liquid level.

(10) In case of suction lift piping

- The end of suction piping should be 1 to 1.5 times of pipe diameter or more away from the bottom of suction tank.
- Install foot valve or check valve in suction piping.

(11) Pipe support

Install the pipe support so that the weight of pipe can not be directly loaded to the pump.

(12) Pipe connection

Pipes must be connected securely so that the air can not be sucked in. If the sealing is not perfect, air is sucked in, which causes pump damage.

4. Discharge piping

(1) Pipe diameter

In case the discharge piping is long, the specified performance may not be obtained because of unexpected pipe resistance if the pipe diameter is the same as pump bore. Calculate the pipe resistance in advance to decide proper diameter of pipe.

(2) Gate valve

Install the gate valve in discharge piping to adjust flow rate and to protect motor from over loading. If the check valve is also installed, recommended arrangement is : Pump → Check valve → Gate valve

(3) Pressure gauge

Install a pressure gauge in discharge piping to check the operating conditions such as discharge head etc.

(4) Check valve

Check valve must be installed in the following cases.

- Discharge piping is longer than 15 to 20 meters.
- Actual head exceeds 15 meters.
- Height difference between liquid level and discharge pipe end exceeds 9 meters.
- When two pumps are used in parallel.

(5) Air vent

If horizontal discharge piping is longer than 15 to 20 meters, install air vent on the way.

(6) Drain

If the liquid must be drained to protect from freezing, install the drain valve.

(7) Pipe support

Install the pipe support so that the pipe weight can not be loaded to pump.

(8) Priming piping

Install piping for priming in case of suction lift.

7. Electrical wiring

Electrical works or wiring must be carried out by qualified and authorized person according to local law or regulation.

- Use the electromagnetic switch which conforms to motor specifications such as voltage and capacity etc.
- If pump is installed outdoor, wiring must be done so that water can not get into switch.
- Electromagnetic switch and push-button switch must securely installed apart from the pump.
- Star-delta starter, inverter or soft starter must be used to start the pump which is equipped with motor of 5.5 kW or more power.

OPERATION

<i>8. Precautions on operation</i>	<i>15</i>
<i>9. Operation (Starting).....</i>	<i>16</i>
<i>10. Pump stopping.....</i>	<i>16</i>

9. Operation (Starting)

1. Fully close discharge valve and fully open suction valve.
2. Fill liquid into pump
 - In case of flooded suction, confirm if suction valve is fully opened.
 - In case of suction lift, prime to fill liquid into suction piping.
3. Check rotating direction of motor.
 - Start motor momentarily (within a second) to check direction. Direction is shown on "arrow" mark on pump. (Clockwise seen from motor fan side)
 - Also check if motor fan smoothly stops when switched off. If it does not stop smoothly, pump rotating parts may be locked. Check the rotating parts.
4. Air vent operation
 - Before pump operation, vent the air in the pump.
 - Fully open the valve in air vent piping and repeat one second running for three to five times.
 - After the air vent running, fully close the discharge valve.
 - Note: In case air vent piping is not equipped, open the discharge valve to repeat momentary run several times.
5. Starting pump
 - Start pump with discharge valve fully closed. (Maximum one minute)
 - Confirm that discharge pressure rises to shut-down pressure.
 - Gradually open discharge valve to get specified pressure (capacity).
 - Note: Pay attention to over-load caused by excessively opened valve.
 - Keep minimum allowable capacity to avoid seizure of bearing or rubbing parts.
 - MDM25 : 20 ℓ /min.
 - MDM32, 40 & 50 : 50 ℓ /min.

10. Pump stopping

1. Slowly close the discharge valve
 - Quick closing of valve may cause water hammer and pump damage.
2. Switch off and stop the pump
 - Confirm if pump stops smoothly. If pump stops suddenly and not smoothly, inspection is needed.
3. When the pump is stopped for a long period, anti freezing measure must be taken so that the liquid can not be frozen in the pump or piping.

Maintenance

<i>11. Troubleshooting.....</i>	<i>18</i>
<i>12. Maintenance & inspection</i>	<i>20</i>
<i>13. Disassembling & assembling.....</i>	<i>21</i>
<i>14. Repair parts list.....</i>	<i>27</i>
<i>15. Mass of pump.....</i>	<i>35</i>

11. Troubleshooting

Troubles	Symptom on pump		Cause	Check & countermeasures
	When disch. valve closed	When disch. valve opened		
Liquid can not be sucked		Press. gauge & vacuum gauge indicate zero.	<ul style="list-style-type: none"> • Lack of priming liquid • Dry running 	<ul style="list-style-type: none"> • Stop pump and replenish pump with liquid to re-start.
	Primed liquid drops quickly		<ul style="list-style-type: none"> • Foot valve is clogged by foreign matters. 	<ul style="list-style-type: none"> • Clean foot valve • Check if foreign matters are not adhered to valve seat.
	After starting, pressure drops as soon as discharge valve is opened.	Pressure gauge vibrates and drops to zero.	<ul style="list-style-type: none"> • Air is sucked from suction pipe or gasket. 	<ul style="list-style-type: none"> • Check if connected flanges are completely sealed. • Check if liquid level of tank is not excessively lowered.
			<ul style="list-style-type: none"> • Disconnected magnet coupling 	<ul style="list-style-type: none"> • Check amperage to see if motor is not overloaded. • Check if foreign matters do not lock impeller or magnet capsule • Check if voltage is normal.
	Press. gauge shows low pressure		<ul style="list-style-type: none"> • Low pump speed • Reverse rotation 	<ul style="list-style-type: none"> • Check wiring or motor. • Interchange wiring connection.
Discharge capacity is small.	Pressure gauge & vacuum gauge indicates normal figure.	Vacuum gauge indicates high figure.	<ul style="list-style-type: none"> • Strainer is clogged by foreign matters. 	<ul style="list-style-type: none"> • Remove foreign matters.
		Vacuum gauge indicates very high figure.	<ul style="list-style-type: none"> • Air pocket in suction piping 	<ul style="list-style-type: none"> • Check and remedy suction piping.
			<ul style="list-style-type: none"> • Foreign matters are clogged at impeller inlet. 	<ul style="list-style-type: none"> • Remove foreign matters.
		Pressure gauge & vacuum gauge vibrate.	<ul style="list-style-type: none"> • Air is sucked in from suction pipe or gasket. 	<ul style="list-style-type: none"> • Check connection part of pipes and retighten it.
<ul style="list-style-type: none"> • Foreign matters clog at discharge side. 	<ul style="list-style-type: none"> • Remove foreign matters. • Remove foreign matters or scales in piping. 			
		Vacuum gauge indicates high but pressure gauge indicates normal.	<ul style="list-style-type: none"> • There are resistance such as air pocket etc. in suction piping. 	<ul style="list-style-type: none"> • Check if there is not protruded section in suction piping.

Troubles	Symptom on pump		Cause	Check & countermeasures
	When disch. valve closed	When disch. valve opened		
Discharge capacity is small.	Pressure gauge & vacuum gauge indicates normal figure.	Pressure is high but vacuum is normal.	<ul style="list-style-type: none"> • Too high actual head or too large pipe resistance 	<ul style="list-style-type: none"> • Check actual head of discharge piping and loss of pipe resistance.
	Pressure is low and vacuum is very low.	Pressure is low and vacuum is low.	<ul style="list-style-type: none"> • Motor rotates in reverse 	<ul style="list-style-type: none"> • Interchange motor wiring.
Motor is overheated.			<ul style="list-style-type: none"> • Lowered power voltage 	<ul style="list-style-type: none"> • Check voltage or frequency.
			<ul style="list-style-type: none"> • Overload 	<ul style="list-style-type: none"> • Check density and viscosity of liquid
			<ul style="list-style-type: none"> • Too high ambient temperature 	<ul style="list-style-type: none"> • Ventilate
Discharge capacity is rapidly reduced.		Vacuum gauge indicates high figure.	<ul style="list-style-type: none"> • Foreign matters clog suction piping. 	<ul style="list-style-type: none"> • Remove foreign matters.
Pump vibrates.			<ul style="list-style-type: none"> • Foundation is not perfect. 	<ul style="list-style-type: none"> • Re-install the pump.
			<ul style="list-style-type: none"> • Loosened mounting bolts. 	<ul style="list-style-type: none"> • Re-tighten
			<ul style="list-style-type: none"> • Cavitation occurs. 	<ul style="list-style-type: none"> • Resolve the reason of cavitation.
			<ul style="list-style-type: none"> • Worn or melted bearing 	<ul style="list-style-type: none"> • Replace
			<ul style="list-style-type: none"> • Broken magnet capsule or spindle 	<ul style="list-style-type: none"> • Replace
			<ul style="list-style-type: none"> • Bad dynamic balance of drive magnet 	<ul style="list-style-type: none"> • Resolve the reason or replace
			<ul style="list-style-type: none"> • Worn bearing of motor 	<ul style="list-style-type: none"> • Replace bearing or motor

12. Maintenance & inspection

⚠ Warning

- Magnetic force is very strong. Pay attention when you handle the magnet capsule or driving magnet so that fingers can not be injured by attraction of magnets.
- The persons who are assisted by electronic devices such as pacemakers etc. are prohibited to approach the magnet capsule and drive magnet.

⚠ Caution

- Magnetic force is very strong. Pay attention iron pieces or powder can not be attracted to the magnet capsule or drive magnet.
- Do not approach the magnetic card to the pump not to break the data.

1. Periodical inspection (Once a six months)

Parts name	Inspection items	Countermeasures
Drive magnet	• If there is no rubbed trace.	• If abnormality is found, consult dealer.
	• If drive magnet housing is correctly mounted or if hex. bolts are not loosened.	• Re-mount the drive magnet to motor shaft or re-tighten the bolt.
	• Decentering of magnet and motor shaft. (Max. 0.1 mm)	• Re-tighten bolts or replace drive magnet. (Consult dealer if replacement is needed.)
Rear casing	• Rubbed trace in inner surface.	• If abnormality is found, consult dealer.
	• If there is no cracks.	• If crack is found, replace.
	• Wear of thrust ring.	• If worn abnormally, consult dealer.
	• Dirty inside.	• Cleaning
Magnet capsule	• If there is no rubbed trace.	• If abnormality is found, consult dealer.
	• If there is no cracks.	• If abnormality is found, consult dealer.
	• Measure the bearing inner diameter.	• Replace if worn excessively.
	• If impeller is securely fixed to magnet capsule.	• If loosened, replace or consult dealer.
Impeller	• Measure the mouth ring thickness.	• Replace if excessively worn.
	• If there is no cracks.	• Replace if cracked.
	• If there is no trace of cavitation. (Abnormal wear, seizure etc.)	• Resolve the reason.
	• Dirt or clog inside impeller.	• Clean
	• Change of dimension.	• Replace if abnormality is found.
Front casing	• Dirty wet-end.	• Clean
	• If there is no cracks.	• Replace if abnormality is found.
	• If there is no abnormal wear, cracks, rubbed traces in liner ring.	• Consult dealer if abnormality is found.
	• Clogged drain.	• Clean
	• If there is no swelling or cracks in gasket.	• Replace if abnormality is found.
	• If there is no rubbed trace.	• Consult if abnormality is found.
Spindle	• If there is no crack.	• Replace if abnormality is found.
	• Wear against bearing	• Replace if excessively worn.

2. Wear limit of bearing and spindle (Time to be replaced)

Unit: mm

Model	Bearing inner dia.		Spindle outer dia.	
	New one	Wear limit	New one	Wear limit
MDM25-□□1	20	21	20	19
MDM25-□□2, MDM32, MDM40	26	27	26	25
MDM50	30	31	30	29

Note1. When the clearance between bearing inner dia. and spindle outer dia. exceeds 1 mm, replace by new ones.

Carbon bearing (CF) type: Replace by new one either spindle or bearing which is worn more (normally it is bearing).

SiC bearing (KK) type: Replace by new ones both bearing and spindle.

2. It may possible that rubbing parts are worn a little in a short time after the pump is started first time, but it is not abnormal.

3. Wear limit of mouth ring (Time to be replaced)

Step between mouth ring and impeller is 2 mm when the pump is shipped. Replace mouth ring when this step becomes zero.

Model	Thickness of mouth ring	
	New one	Wear limit
MDM25, 32	8 mm	6 mm
MDM40, 50	9 mm	7 mm

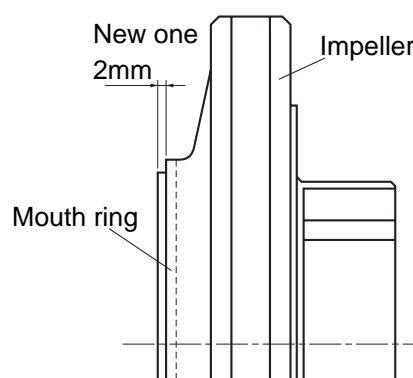

13. Disassembling & assembling

Tool list

Following tools are necessary to disassemble and assemble the pump.

Tool	MDM25-□□1	MDM25-□□2 MDM32, 40, 50	Remarks
Spanner	13 mm, 17 mm, 19 mm	13 mm, 19 mm, 24 mm	1 pc/each
Hex. wrench	4 mm, 5 mm	4 mm, 5 mm	1 pc/each
Plastic round bar	24 mm dia. × 80 L	34 mm dia. × 100 L	To remove & mount bearing
Plastic welder or industrial dryer	1 unit		
Hand press	1 unit		

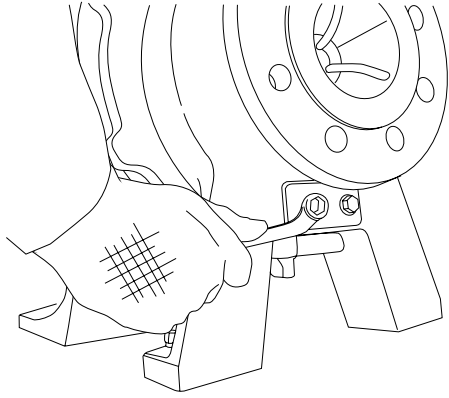

1. Disassembly of pump casing

- (1) Remove hex. bolts (909.1) and drain plate (122.1) to drain liquid inside.

For the type without drain, disassemble the pump after the liquid inside is neutralized or the pump is cleaned by water.

Warning

If all the hex. bolts are loosened simultaneously, liquid will splash and will result in injury.

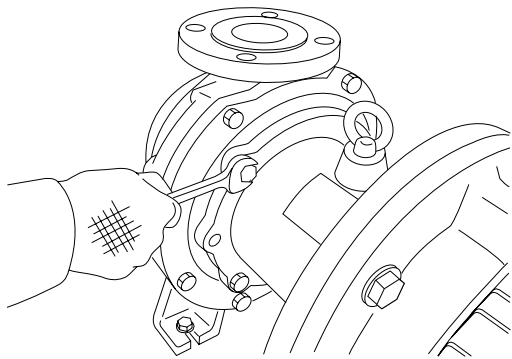

- (2) Remove hex. bolts (901.7) of foot support (330).
- (3) Remove hex. bolts (901.5) of pump side.

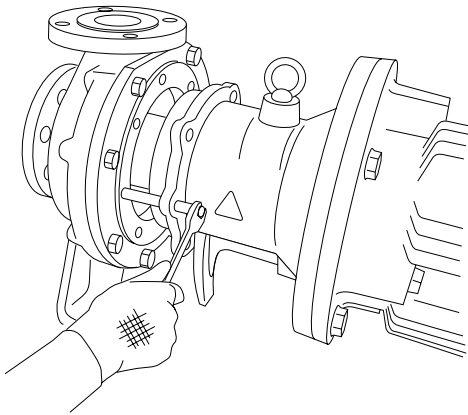

- (4) Separate pump body from foot support by screwing two bolts (M12 × 100, and M10 × 50 for MDM25-1) from motor side through bolt threads holes of foot support. Screw in bolts alternatively to remove foot support backward. (Screw in bolts by approx. 80 mm).
- (5) Pull out backward motor and foot support by lifting them by crane or so. Take care so that the motor and foot support are pulled out straight to backward. Otherwise, drive magnet (858) touches the rear casing (158).

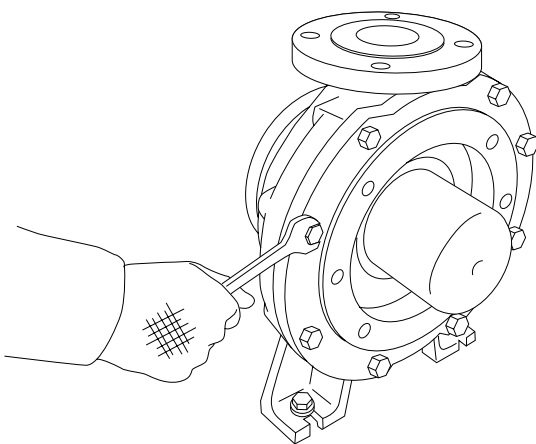

- (6) Remove hex. bolts (901.4) of cover (100.2) to pull out rear casing holder.

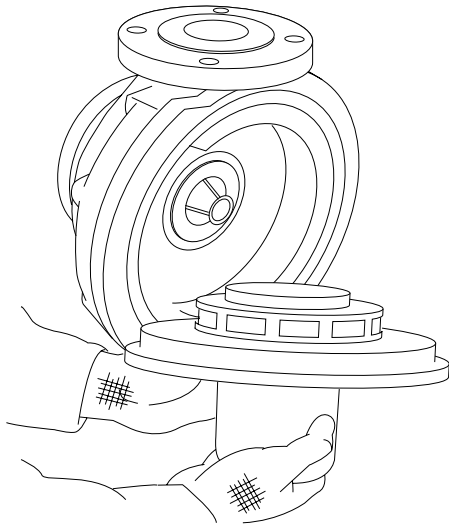

- (7) Then, remove rear casing (158) from rear casing cover (159). If rear casing is hard to remove, remove it by turning. Pay attention not to drop the impeller (230)/magnet capsule (859) unit which is located in the rear casing.

2. Removal of impeller and bearing

- (1) Stand up the claw of rear ring (314.4) after it was heated by plastic welder or industrial dryer.

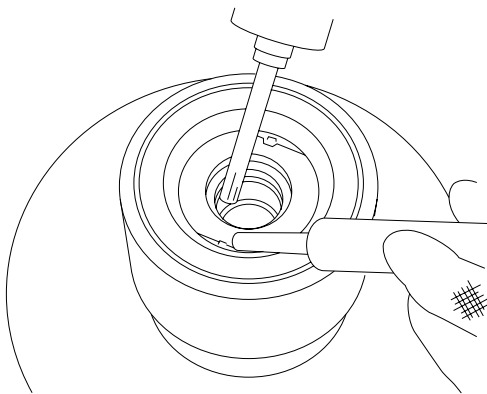

- (2) Apply plastic made round bar of 34 mm dia. × 100L (24 mm dia. × 80 L for MDM25) on the bearing end through impeller side and remove bearing (310) and rear ring (314.4) using hand press etc.

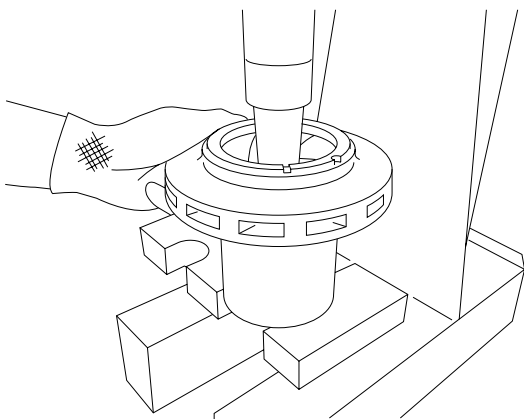

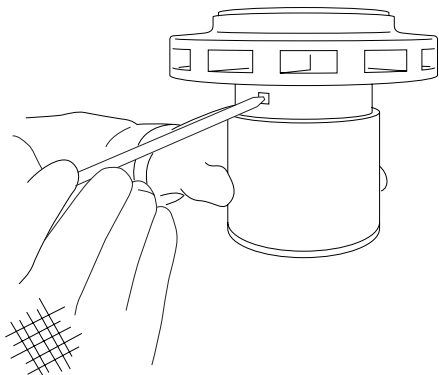

- (3) Remove impeller fixing pin (942) of upper part of magnet capsule by pushing it by screw driver or like. (Ask IWAKI for removing impeller of PFA material type.)

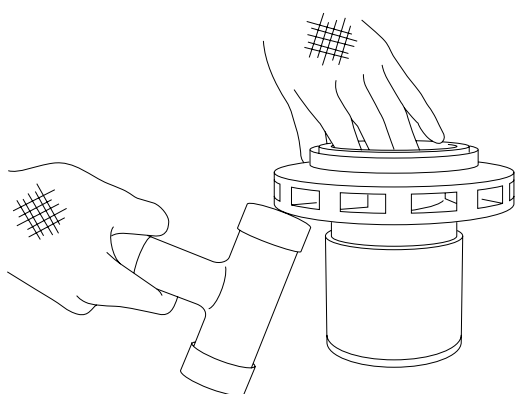

- (4) Remove impeller (230) from magnet capsule (859). If it is hard to remove, slightly strike the impeller back side with plastic hammer.

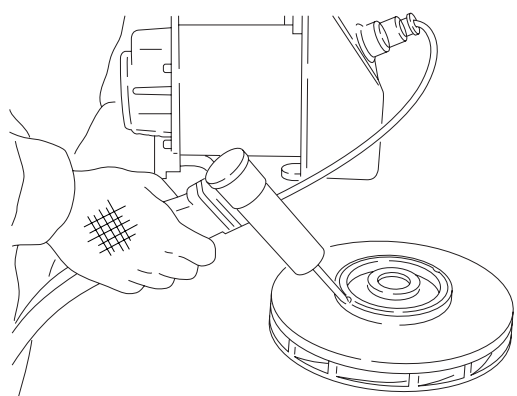

3. Replacement of mouth ring

- (1) Stand up the claw of impeller after it was heated by plastic welder or industrial dryer.
- (2) Replace the mouth ring (314.2), and fix it by heating the claw with plastic welder or industrial dryer and push the claw down.

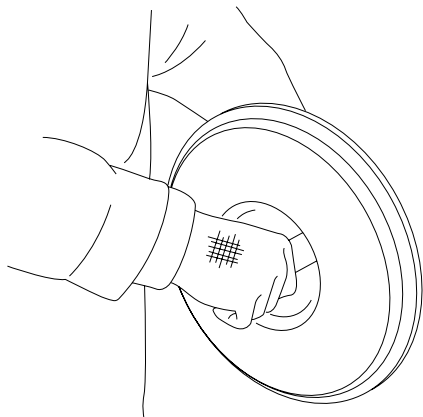

4. Replacement of spindle

- (1) Spindle (210) is slightly pressed into rear casing (158). Pull out the spindle by a hand.
If it is hard to pull it out, pull it out by shaking it right and left.
- (2) Wipe off the stain at spindle inserted part of rear casing and insert the spindle. Use hand press or like if it is hard to insert.

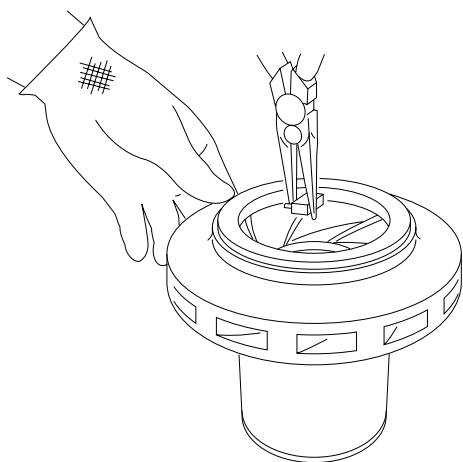

5. Mounting impeller and bearing

- (1) Put together the depressed and hollowed parts of impeller and magnet capsule and insert the impeller into magnet capsule.
At the same time, align the insert ports of impeller pin.
- (2) Insert the impeller pin. Pliers are useful for easy insertion.

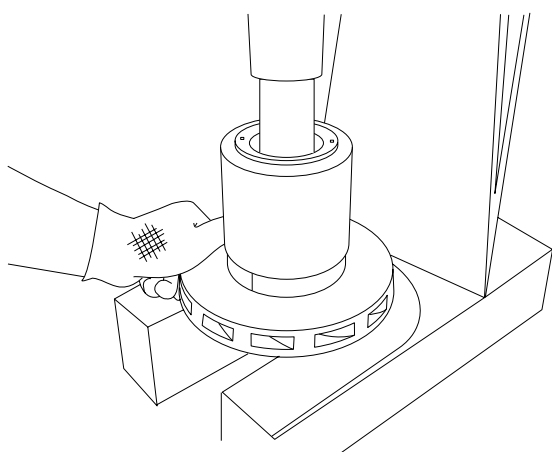

- (3) Put the magnet capsule on top and insert the bearing into magnet capsule by using hand press. Before starting the works, warm the magnet capsule putting it in water of 90 deg. C.
- (4) Then, insert the rear ring and fix it by heating the claw with plastic welder or industrial dryer to weld it and push it to rear ring.

6. Assembling

Assemble the pump in reverse procedures paying attention to the following points.

- Replacement of gasket

Do not fail to replace the gasket by new one. Pay attention so that it cannot be forgotten to be put or it can be mounted correctly without twist or bite. Clean the sealing surface before mounting the gasket.

- Tightening of bolts

Tighten the bolts diagonally and evenly.

- Cleaning of magnet capsule

Powdered iron or like can be attracted to the magnet capsule. Remove the foreign matters before assembling.

(1) Mount the gasket on front casing (100.1).

(2) Mount impeller/magnet capsule unit on rear casing and mount them on front casing by rotating the rear casing right and left.

(3) Then mount the rear casing cover and securely fix the rear casing support by tightening hex. bolts diagonally and evenly.

- Tightening torque

MDM25-□1 : 44.1 N · m (450 kgf-m)

MDM25-□2, MDM32, MDM40, MDM50 : 58.8 N · m
(600 kgf-m)

(4) Remove foreign matters from the drive magnet.

(5) Lift the foot support/motor and insert the faucet part of foot support into the rear casing support by unscrewing the bolts alternatively. (Before the works, attached bolts (M12 × 100) are screwed by half into the foot support.

(6) Then, fix the foot support and rear casing support by hex. bolts. Foot support must be inserted straight, otherwise, drive magnet will touch the rear casing cover.

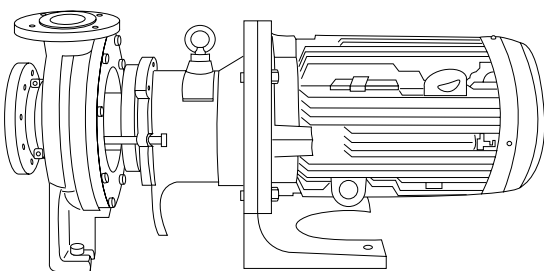
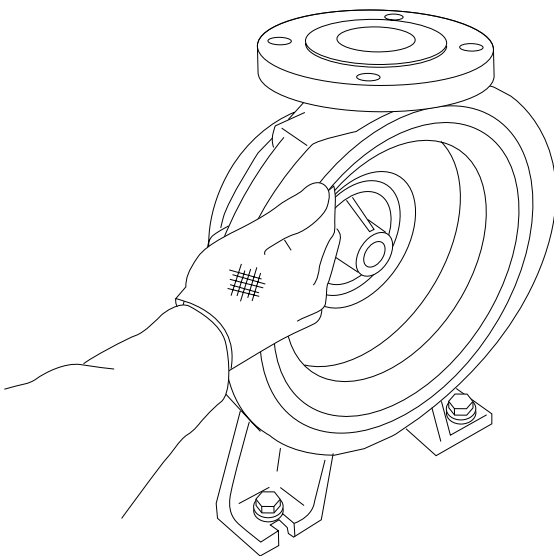

14. Repair parts list

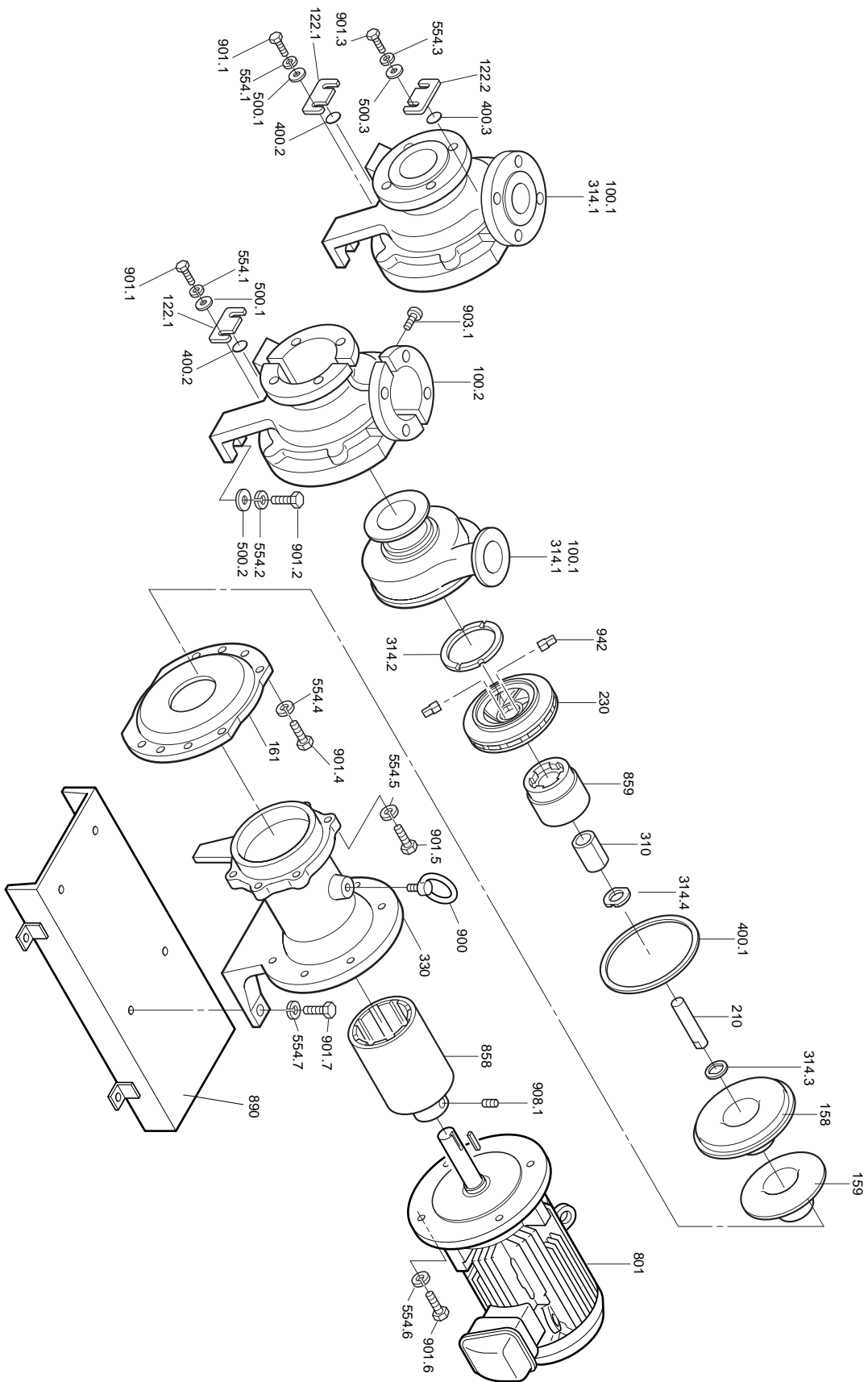

NO	Parts name	Model code	Material	Qty	MDM25-1 Low head Code No.	MDM25-2 High head Code No.	MDM32 Code No.	MDM40 Code No.	MDM50 5.5/7.5kW Code No.	MDM50 11/15kW Code No.	Remarks	
100.1+	Front casing	PKK	PFA+SiC	1	MDM0001						With drain hole	
314.1		EKK	CFRETFE+SiC	1	MDM0002	MDM0110	MDM0203	MDM0279	MDM0366	MDM0366	With drain hole	
		ECF	CFRETFE+High purity alumina ceramic	1	MDM0003	MDM0111	MDM0204	MDM0280	MDM0367	MDM0367	With drain hole	
		PKK	PFA+SiC	1	MDM0004							Without drain hole
		EKK	CFRETFE+SiC	1	MDM0005	MDM0112	MDM0205	MDM0281	MDM0368	MDM0368	MDM0368	Without drain hole
100.1+	Front casing unit	ECF	CFRETFE+High purity alumina ceramic	1	MDM0006	MDM0113	MDM0206	MDM0282	MDM0369	MDM0369	Without drain hole	
314.1		PKK	PFA+Ductile iron+SiC	1		MDM0499	MDM0503	MDM0506	MDM0493	MDM0496	With drain hole	
100.2+	Cover unit	PKK	PFA+Ductile iron+SiC	1		MDM0509	MDM0504	MDM0507	MDM0494	MDM0497	Without drain hole	
903.1		PKK	Ductile iron	1	MDM0501						For MDM25-1PFA	
122.1	Drain plate	EKK, ECF	Ductile iron	1	MDM0502	MDM0500	MDM0505	MDM0508	MDM0495	MDM0498	For ETFE	
122.2			Steel	1	MDM0009	MDM0009	MDM0009	MDM0009	MDM0009	MDM0009		
158	Air vent plate		Steel	1	MDM0009	MDM0009	MDM0009	MDM0009	MDM0009	MDM0009	For PFA	
159	Rear casing cover	PKK	PFA	1	MDM0010	MDM0117	MDM0210	MDM0210	MDM0370	MDM0370		
		EKK, ECF	CFRETFE	1	MDM0011	MDM0118	MDM0211	MDM0211	MDM0371	MDM0371		
161	Rear casing support		FRP	1	MDM0012	MDM0119	MDM0212	MDM0212	MDM0119	MDM0119		
210	Spindle	PKK, EKK	Ductile iron	1	MDM0013	MDM0120	MDM0213	MDM0213	MDM0120	MDM0120		
		ECF	SiC	1	MDM0014	MDM0121	MDM0121	MDM0121	MDM0372	MDM0372		
230	Impeller		High density carbon	1	MDM0015	MDM0122	MDM0122	MDM0122	MDM0373	MDM0373		
230+		Impeller ass'y										
314.2												
230+	Impeller/magnet capsule ass'y											
310+												
314.2+												
314.4+												
859+												
942												
310	Bearing	PKK, EKK	SiC	1	MDM0016	MDM0123	MDM0123	MDM0123	MDM0374	MDM0374		

Refer to impeller parts list

NO	Parts name	Model code	Material	Qty	MDM25-1 Low head Code No.	MDM25-2 High head Code No.	MDM32 Code No.	MDM40 Code No.	MDM50 5.5/7.5kW Code No.	MDM50 11/15kW Code No.	Remarks
314.2	Mouth ring	PKK, EKK	SiC	1	MDM0018	MDM0018	MDM0018	MDM0488	MDM0376	MDM0376	
314.3	Rear thrust	ECF	PTFE	1	MDM0019	MDM0019	MDM0019	MDM0489	MDM0377	MDM0377	
314.4	Rear ring	PKK, EKK	PTFE	1	MDM0020	MDM0125	MDM0125	MDM0125	MDM0378	MDM0378	
314.4	Rear ring	PKK, EKK	SiC	1	MDM0021	MDM0126	MDM0126	MDM0126	MDM0126	MDM0126	
330	Foot support	ECF	High purity alumina ceramic	1	MDM0022	MDM0127	MDM0127	MDM0127	MDM0127	MDM0127	
330	Foot support	F015, F022	Ductile iron	1	MDM0023						
400.1	Gasket	F040	Ductile iron	1		MDM0128	MDM0128	MDM0128			
400.2	Drain gasket	F055, F075	Ductile iron	1		MDM0129	MDM0129	MDM0129			
400.3	Air vent gasket	F110	Ductile iron	1					MDM0467		
400.1	Gasket		PTFE	1	MDM0024	MDM0130	MDM0214	MDM0214	MDM0130	MDM0130	
400.2	Drain gasket		PTFE	1	MDM0025	MDM0025	MDM0025	MDM0025	MDM0025	MDM0025	With drain type
400.3	Air vent gasket		PTFE	1	MDM0025	MDM0025	MDM0025	MDM0025	MDM0025	MDM0025	With drain of PFA
500.1	Plain washer		Stainless steel	2	MDM0026	MDM0026	MDM0026	MDM0026	MDM0026	MDM0026	
500.2	Plain washer		Stainless steel	2	MDM0027	MDM0027	MDM0027	MDM0027	MDM0027	MDM0027	
500.3	Plain washer		Stainless steel	2	MDM0026	MDM0026	MDM0026	MDM0026	MDM0026	MDM0026	
554.1	Spring washer		Stainless steel	2	MDM0028	MDM0028	MDM0028	MDM0028	MDM0028	MDM0028	
554.2	Spring washer		Stainless steel	2	MDM0029	MDM0029	MDM0029	MDM0029	MDM0029	MDM0029	
554.3	Spring washer		Stainless steel	2	MDM0028	MDM0028	MDM0028	MDM0028	MDM0028	MDM0028	
554.4	Spring washer		Stainless steel	6 or 8	MDM0030	MDM0029	MDM0029	MDM0029	MDM0029	MDM0029	6 pcs for MDM25-1
554.5	Spring washer		Stainless steel	4	MDM0030	MDM0029	MDM0029	MDM0029	MDM0029	MDM0029	
554.6	Spring washer		Stainless steel	4	MDM0030	MDM0029	MDM0029	MDM0029	MDM0029	MDM0490	
554.7	Spring washer		Stainless steel	2	MDM0029	MDM0029	MDM0029	MDM0029	MDM0029	MDM0029	
801	Motor			1							
858	Drive magnet unit	F015	Rare earth magnet + steel	1	MDM0031						
		F022	Rare earth magnet + steel	1	MDM0032						
		F040	Rare earth magnet + steel	1		MDM0131	MDM0131	MDM0131			
		F055	Rare earth magnet + steel	1		MDM0132	MDM0132	MDM0132			
		F075	Rare earth magnet + steel	1				MDM0286	MDM0286	MDM0286	
		F110	Rare earth magnet + steel	1						MDM0468	

NO	Parts name	Model code	Material	Qty	MDM25-1 Low head Code No.	MDM25-2 High head Code No.	MDM32 Code No.	MDM40 Code No.	MDM50 5.5/7.5kW Code No.	MDM50 11/15kW Code No.	Remarks
		PKK-F022	Rare earth magnet + PFA	1	MDM0033						
		PKK-F040	Rare earth magnet + PFA	1		MDM0133	MDM0133				
		PKK-F055	Rare earth magnet + PFA	1		MDM0133	MDM0133	MDM0133			
		PKK-F075	Rare earth magnet + PFA	1			MDM0287	MDM0287			
		PKK-F110	Rare earth magnet + PFA	1					MDM0469		
		EKK/ECF-F015	Rare earth magnet + CFRETFE	1	MDM0034						
		EKK/ECF-F022	Rare earth magnet + CFRETFE	1	MDM0034						
		EKK/ECF-F037	Rare earth magnet + CFRETFE	1		MDM0134	MDM0134				
		EKK/ECF-F055	Rare earth magnet + CFRETFE	1		MDM0134	MDM0134	MDM0134			
		EKK/ECF-F075	Rare earth magnet + CFRETFE	1				MDM0288			
		EKK/ECF-F110	Rare earth magnet + CFRETFE	1					MDM0470		
890	Base plate		Steel	1	MDM0035	MDM0135	MDM0135	MDM0135	MDM0135	MDM0471	
900	Eye bolt		Steel	1	MDM0036	MDM0036	MDM0036	MDM0036	MDM0036	MDM0036	
901.1	Hex. head bolt		Stainless steel	2	MDM0037	MDM0037	MDM0037	MDM0037	MDM0037	MDM0037	
901.2	Hex. head bolt		Stainless steel	2	MDM0038	MDM0136	MDM0136	MDM0136	MDM0136	MDM0136	
901.3	Hex. head bolt		Stainless steel	2	MDM0037	MDM0037	MDM0037	MDM0037	MDM0037	MDM0037	
901.4	Hex. head bolt		Stainless steel	6 or 8	MDM0039	MDM0137	MDM0137	MDM0137	MDM0137	MDM0137	6 pcs for MDM25-1
901.5	Hex. head bolt		Stainless steel	4	MDM0040	MDM0136	MDM0136	MDM0136	MDM0136	MDM0136	
901.6	Hex. head bolt		Stainless steel	4	MDM0041	MDM0136	MDM0136	MDM0136	MDM0136	MDM0491	
901.7	Hex. head bolt		Stainless steel	2	MDM0042	MDM0136	MDM0136	MDM0136	MDM0136	MDM0136	
903.1	Hex. socket head bolt		Steel	5	MDM0043	MDM0043	MDM0043	MDM0043	MDM0043	MDM0043	
908.1	Hex. socket head bolt		Steel	2	MDM0044	MDM0044	MDM0044	MDM0044	MDM0044	MDM0044	
942	Impeller pin		PFA	2	MDM0045	MDM0138	MDM0138	MDM0138	MDM0138	MDM0138	

MDM25 Impeller parts list

Model	NO	Parts name	Impeller size code	Motor power	Q'ty/ unit	Parts code No.		
						PKK	EKK	ECF
MDM25-1	230	Impeller	165		1	MDM0046	MDM0067	MDM0067
			160		1	MDM0047	MDM0068	MDM0068
			150		1	MDM0048	MDM0069	MDM0069
			140		1	MDM0049	MDM0070	MDM0070
			130		1	MDM0050	MDM0071	MDM0071
	230+ 314.2	Impeller a'ssy	165		1	MDM0053	MDM0074	MDM0093
			160		1	MDM0054	MDM0075	MDM0094
			150		1	MDM0055	MDM0076	MDM0095
			140		1	MDM0056	MDM0077	MDM0096
			130		1	MDM0057	MDM0078	MDM0097
	230+ 310+ 314.2+ 314.4+ 859+ 942	Impeller/magnet capsule a'ssy	165	1.5kW	1	MDM0060	MDM0085	MDM0101
			160	1.5kW	1	MDM0061	MDM0086	MDM0102
			150	1.5kW	1	MDM0062	MDM0087	MDM0103
			140	1.5kW	1	MDM0063	MDM0088	MDM0104
			130	1.5kW	1	MDM0064	MDM0089	MDM0105
			165	2.2kW	1	MDM0060	MDM0085	MDM0101
			160	2.2kW	1	MDM0061	MDM0086	MDM0102
			150	2.2kW	1	MDM0062	MDM0087	MDM0103
			140	2.2kW	1	MDM0063	MDM0088	MDM0104
130			2.2kW	1	MDM0064	MDM0089	MDM0105	
MDM25-2	230	Impeller	195		1	MDM0139	MDM0163	MDM0163
			190		1	MDM0140	MDM0164	MDM0164
			180		1	MDM0141	MDM0165	MDM0165
			170		1	MDM0142	MDM0166	MDM0166
			160		1	MDM0143	MDM0167	MDM0167
	230+ 314.2	Impeller ass'y	195		1	MDM0147	MDM0171	MDM0187
			190		1	MDM0148	MDM0172	MDM0188
			180		1	MDM0149	MDM0173	MDM0189
			170		1	MDM0150	MDM0174	MDM0190
			160		1	MDM0151	MDM0175	MDM0191
	230+ 310+ 314.2+ 314.4+ 859+ 942	Impeller/magnet capsule a'ssy	195	4.0kW	1	MDM0155	MDM0179	MDM0195
			190	4.0kW	1	MDM0156	MDM0180	MDM0196
			180	4.0kW	1	MDM0157	MDM0181	MDM0197
			170	4.0kW	1	MDM0158	MDM0182	MDM0198
			160	4.0kW	1	MDM0159	MDM0183	MDM0199
			195	5.5kW	1	MDM0155	MDM0179	MDM0195
			190	5.5kW	1	MDM0156	MDM0180	MDM0196
			180	5.5kW	1	MDM0157	MDM0181	MDM0197
			170	5.5kW	1	MDM0158	MDM0182	MDM0198
			160	5.5kW	1	MDM0159	MDM0183	MDM0199

Note: Tell us pump model code and Mfg. No. when impeller is ordered because actual impeller size may not be the same as those shown here.

MDM32/40/50 Impeller parts list

Model	NO	Parts name	Impeller size	Motor power	Q'ty/ unit	Parts code No.					
						PKK	EKK	ECF			
MDM32	230	Impeller	165		1	MDM0215	MDM0239	MDM0239			
			160		1	MDM0216	MDM0240	MDM0240			
			150		1	MDM0217	MDM0241	MDM0241			
			145		1	MDM0218	MDM0242	MDM0242			
			140		1	MDM0219	MDM0243	MDM0243			
			130		1	MDM0220	MDM0244	MDM0244			
			120		1	MDM0221	MDM0245	MDM0245			
	230+ 314.2	Impeller ass'y	165		1	MDM0223	MDM0247	MDM0263			
			160		1	MDM0224	MDM0248	MDM0264			
			150		1	MDM0225	MDM0249	MDM0265			
			145		1	MDM0226	MDM0250	MDM0266			
			140		1	MDM0227	MDM0251	MDM0267			
			130		1	MDM0228	MDM0252	MDM0268			
			120		1	MDM0229	MDM0253	MDM0269			
	230+ 310+ 314.2+ 314.4+ 859+ 942	Impeller/magnet capsule ass'y	165	4.0kW	1	MDM0231	MDM0255	MDM0271			
			160	4.0kW	1	MDM0232	MDM0256	MDM0272			
			150	4.0kW	1	MDM0233	MDM0257	MDM0273			
			145	4.0kW	1	MDM0234	MDM0258	MDM0274			
			140	4.0kW	1	MDM0235	MDM0259	MDM0275			
			130	4.0kW	1	MDM0236	MDM0260	MDM0276			
			120	4.0kW	1	MDM0237	MDM0261	MDM0277			
			165	5.5kW	1	MDM0231	MDM0255	MDM0271			
			160	5.5kW	1	MDM0232	MDM0256	MDM0272			
			150	5.5kW	1	MDM0233	MDM0257	MDM0273			
			145	5.5kW	1	MDM0234	MDM0258	MDM0274			
			140	5.5kW	1	MDM0235	MDM0259	MDM0275			
			130	5.5kW	1	MDM0236	MDM0260	MDM0276			
			120	5.5kW	1	MDM0237	MDM0261	MDM0277			
			MDM40	230	Impeller	165		1	MDM0379	MDM0481	MDM0481
						160		1	MDM0475	MDM0482	MDM0482
150		1				MDM0476	MDM0483	MDM0483			
140		1				MDM0477	MDM0484	MDM0484			
130		1				MDM0478	MDM0485	MDM0485			
120		1				MDM0479	MDM0486	MDM0486			
110		1				MDM0480	MDM0487	MDM0487			
230+ 314.2	Impeller ass'y	165			1	MDM0296	MDM0324	MDM0345			
		160			1	MDM0297	MDM0325	MDM0346			
		150			1	MDM0298	MDM0326	MDM0347			
		140			1	MDM0299	MDM0327	MDM0348			
		130			1	MDM0300	MDM0328	MDM0349			
		120			1	MDM0301	MDM0329	MDM0350			
		110			1	MDM0302	MDM0330	MDM0351			

Model	NO	Parts name	Impeller size	Motor power	Q'ty/ unit	Parts code No.		
						PKK	EKK	ECF
MDM40	230+	Impeller/magnet capsule ass'y	165	4.0kW	1	MDM0303	MDM0331	MDM0352
	310+		160	4.0kW	1	MDM0304	MDM0332	MDM0353
	314.2+		150	4.0kW	1	MDM0305	MDM0333	MDM0354
	314.4+		140	4.0kW	1	MDM0306	MDM0334	MDM0355
	859+		130	4.0kW	1	MDM0307	MDM0335	MDM0356
	942		120	4.0kW	1	MDM0308	MDM0336	MDM0357
			110	4.0kW	1	MDM0309	MDM0337	MDM0358
			165	5.5kW	1	MDM0303	MDM0331	MDM0352
			160	5.5kW	1	MDM0304	MDM0332	MDM0353
			150	5.5kW	1	MDM0305	MDM0333	MDM0354
			140	5.5kW	1	MDM0306	MDM0334	MDM0355
			130	5.5kW	1	MDM0307	MDM0335	MDM0356
			120	5.5kW	1	MDM0308	MDM0336	MDM0357
			110	5.5kW	1	MDM0309	MDM0337	MDM0358
			165	7.5kW	1	MDM0310	MDM0338	MDM0359
			160	7.5kW	1	MDM0311	MDM0339	MDM0360
			150	7.5kW	1	MDM0312	MDM0340	MDM0361
			140	7.5kW	1	MDM0313	MDM0341	MDM0362
			130	7.5kW	1	MDM0314	MDM0342	MDM0363
			120	7.5kW	1	MDM0315	MDM0343	MDM0364
	110	7.5kW	1	MDM0316	MDM0344	MDM0365		

Note: Tell us pump model code and Mfg. No. when impeller is orderd because actual impeller size may not be the same as those shown here.

MDM50 Impeller parts list

Model	NO	Parts name	Impeller size	Motor power	Q'ty/ unit	Parts code No.		
						PKK	EFF	ECF
MDM50	230	Impeller	165		1	MDM0289	MDM0317	MDM0317
			160		1	MDM0290	MDM0318	MDM0318
			150		1	MDM0291	MDM0319	MDM0319
			140		1	MDM0292	MDM0320	MDM0320
			130		1	MDM0293	MDM0321	MDM0321
			120		1	MDM0294	MDM0322	MDM0322
			110		1	MDM0295	MDM0323	MDM0323
	230+ 314.2	Impeller ass'y	165		1	MDM0380	MDM0408	MDM0436
			160		1	MDM0381	MDM0409	MDM0437
			150		1	MDM0382	MDM0410	MDM0438
			140		1	MDM0383	MDM0411	MDM0439
			130		1	MDM0384	MDM0412	MDM0440
			120		1	MDM0385	MDM0413	MDM0441
			110		1	MDM0386	MDM0414	MDM0442
	230+ 310+ 314.2+ 314.4+ 859+ 942	Impeller/magnet capsule ass'y	165	5.5kW	1	MDM0387	MDM0415	MDM0443
			160	5.5kW	1	MDM0388	MDM0416	MDM0444
			150	5.5kW	1	MDM0389	MDM0417	MDM0445
			140	5.5kW	1	MDM0390	MDM0418	MDM0446
			130	5.5kW	1	MDM0391	MDM0419	MDM0447
			120	5.5kW	1	MDM0392	MDM0420	MDM0448
			110	5.5kW	1	MDM0393	MDM0421	MDM0449
			165	7.5kW	1	MDM0394	MDM0422	MDM0450
			160	7.5kW	1	MDM0395	MDM0423	MDM0451
			150	7.5kW	1	MDM0396	MDM0424	MDM0452
			140	7.5kW	1	MDM0397	MDM0425	MDM0453
			130	7.5kW	1	MDM0398	MDM0426	MDM0454
			120	7.5kW	1	MDM0399	MDM0427	MDM0455
			110	7.5kW	1	MDM0400	MDM0428	MDM0456
			165	11kW	1	MDM0401	MDM0429	MDM0457
			160	11kW	1	MDM0402	MDM0430	MDM0458
			150	11kW	1	MDM0403	MDM0431	MDM0459
			140	11kW	1	MDM0404	MDM0432	MDM0460
			130	11kW	1	MDM0405	MDM0433	MDM0461
120			11kW	1	MDM0406	MDM0434	MDM0462	
110	11kW	1	MDM0407	MDM0435	MDM0463			

Note: Tell us pump model code and Mfg. No. when impeller is ordered because actual impeller size may not be the same as shown here.

15. Mass of pump

Model	Output (kW)	Total mass without motor & with baseplate (kg)	Total mass without motor & without baseplate (kg)
MDM25 - □□1	1.5	67	42
	2.2	67	42
MDM25 - □□2	4.0	89	64
	5.5	96	66
MDM32	4.0	84	59
	5.5	91	61
MDM40	4.0	89	59
	5.5	91	61
	7.5	91	61
MDM50	5.5	96	71
	7.5	96	71
	11	130	85

IWAKI PUMPS



IWAKI CO., LTD

6-6 Kanda-sudacho, 2-chome, Chiyoda-ku

Tokyo 101-8558 Japan

Tel: (81) 3 3254 2935 Fax: (81) 3 3252 8892

T382 99/7