

Systeme für Aquakultur,
Aquaristik, Labore und
zur Wasseraufbereitung

Systems for aqua culture,
sea water aquaria, labs and
water desalination and purification

Système pour l'Aquaculture,
l'Aquariophilie, le Laboratoire et
le Traitement de l'Eau



AquaCare GmbH & Co. KG
Am Wiesenbusch 11
D-45966 Gladbeck
Tel.: +49-2043-375758-0
Fax: +49-2043-375758-90
<http://www.aquacare.de>
e-mail: info@aquacare.de

Turbo Reactor size 4-5

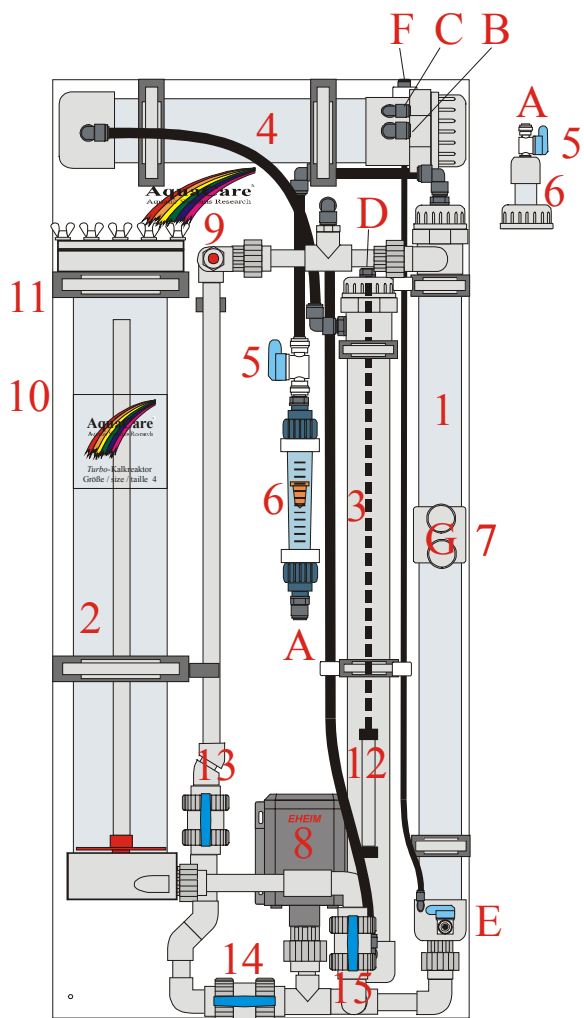
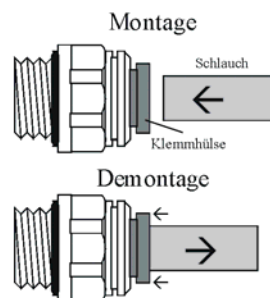

Fig. I



Fig. II



Instruction Manual	
A	Water inlet (with and without flow meter)
B	Water outlet
C	Air outlet
D	Air inlet
E	Water drain
F	CO ₂ inlet
G	3/4" unions (connection for CO ₂ sensor)
1	CO ₂ tube
2	Calcite tube
3	Neutralisation tube
4	Sediment tube
5	Water inlet valve
6	Inspection glass (not with flow meter)
7	Muffle
8	Circulation pump
9	pH sensor connector
10	Maximum filling mark
11	Upper sieve
12	Air stone
13	Ball valve: to CO ₂ tube
14	Ball valve: bypass
15	Ball valve: pump pressure

Fig. III

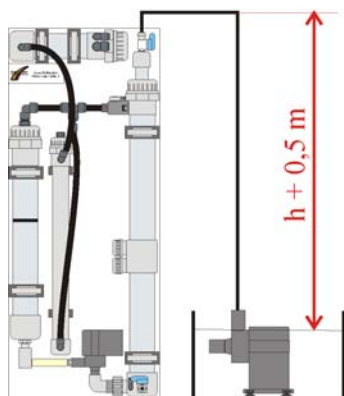
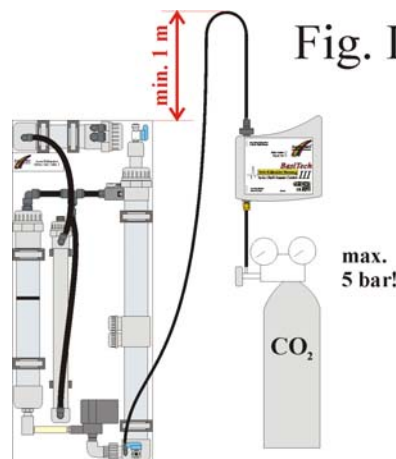

Fig. IV



Instruction manual of AquaCare *Turbo Chalk Reactor – Ca-Reactor*

Principle of the Turbo Chalk Reactors

In the CO₂ tube (1) CO₂ is dosed to lower the pH of the water (about 5,2 to 5,5). The circulation pump (8) pumps the water into the next tube - the calcite tube (2). In this compartment the calcite material is dissolved. The calcite is split into calcium and hydrogen carbonate (alkalinity). The enriched water flows back to the CO₂ tube (1)- the cycle is closed.

The same volume of incoming water flows out of the system - you can see in inflow in the small transparent tube (6) above the CO₂ tube or at the inlet flow meter (option). The volume is controlled with the small ball valve (5). The outflow reaches the neutralizing tube (3). In this compartment air strips out the CO₂ (about 80%) with the help of an air stone (12). The neutralized water flows to the sediment tube (4). Most of the very fine sediment, caused by friction in the calcite tube, sinks down on the bottom of the sediment tube. In this tube small amounts of phosphate adsorbs (chemo sorption) at the sediments.

Mounting the unit

Best place for the reactor:

The *Turbo* Chalk Reactor must be mounted vertically to guarantee the function. Please use the screws (in the plastic bag) to fix the reactor at a wall (stone or wood). If you have another wall please use special plugs.

The AquaCare *Turbo* Chalk Reactor should be mounted in the near of the aquarium or filter tank. The water outlet hose must be fixed in a slope – the hose never should go uphill to the tank (Fig. I). Therefore the sediment tube must be higher than the aquarium or filter tank. You may mount the sediment tube away from the reactor for assemble the tube to the aquarium downhill. But please consider, that you need a stronger air pump and water inlet pump for the neutralizing tube (each meter you need 100 mbar more pressure). Additionally you must take a longer hose from the neutralizing tube to the sediment tube.

Additionally you need an electrical connection in the near (within 1 meter). The best place is a dark place. If the reactor is in the sun you have to cover a black foil around the transparent tubes to prevent algae growth.

Assembling the unit:

For transport some parts of the reactor are disassembled. Assemble the upper connection with pH-connector to the CO₂-tube. Hang in the circulation pump at its wall plate and fix the lower tubes to calcite tube – CO₂-tube – pump. If an AquaCare *Turbo* control is delivered mount the CO₂ sensor at the connection (G) – before unscrew the caps from the gray muffler (7).

Connection of the hoses (see Fig. II):

For mounting the hoses cut them with a sharp knife. For the push fit fittings only use the black AquaCare PE hose/tube. Otherwise use the connectors to other hoses (PVC or silicone).

The pressure hose is pushed into the push fit fitting until it cannot be pushed further. The tube should be gently pulled to ensure that the connection is sound. The connection can be released by pushing back the collet and pulling the tube out.

Water Outlet: (see Fig. I)

The water outlet (B) of the reactor will be made with the 10mm hose. Please take care to assemble the hose downhill from reactor to tank/aquarium. If not the water will flow out off the reactor (C). The hose must end over the water level! To prevent turbid water in the aquarium caused by very fine sediments you can direct the water to a sediment filter filled with fine material, e.g. filter floss. You may assemble the air outlet (C) parallel to the water outlet hose – if the water outlet hose is blocked the water will flow through the air hose. The air hose should never be under the water level! Otherwise the CO₂ in the air will lower the pH of the aquarium water and bubbling sound will occur.

Water Inlet: (see Fig. III)

You can realize the water inlet (A) with an extra circulation pump or with a bypass from the main circulation pump that pumps the water from the filter tank to the aquarium. The pump must have enough pressure; the water flow does not matter. The best solution is a bypass: you do not need an extra pump and the water from a bypass contains less sediments that are able to block the water inlet valve. A water pass meter (option) is a very easy way to regulate the right water inflow. The water inlet (A) of the AquaCare *Turbo* Chalk reactor is at the top of the CO₂ tube (1). You can see the inflowing water at the inspection glass (6). *Turbo* Chalk reactors with built in water pass meters must be supplied at the bottom of the pass meter. If you do not use the original AquaCare PE hoses you can use the hose adapter (packed in the plastic bag). If you have questions or problems with the connections please ask your distributor or AquaCare.

CO₂ supply: (see Fig. IV)

For operation the *Turbo* Chalk reactor needs a CO₂ supply, too. Please use CO₂ pressure tanks – other systems with pressures below 0,5 bar (7 PSI) will not work properly. **Please read the instruction manual for the pressure tank and pressure relief valve carefully!** The pressure of the pressure relief valve should be between 0,5 and 2 bar (7 and 30 PSI). Never raise the pressure above 5 bar (45 PSI)! Never work without a GOOD check valve (check valves for air are not suitable!). Back flowing water will destroy solenoids and pressure relief valves. Please assemble the CO₂ hose with a security loop with minimum 1 meter.

Air supply for neutralizing tube:

The air inlet (D) is at the top of the neutralizing tube (3). Assemble the air hose with a security loop of minimum 1 meter, too. Check valves normally reduce the air pressure drastically and they will not work 100%ly. Back flowing water will destroy the air pump. If the pH of the out coming water is below 7,0 the air pump is too weak! In that case use a stronger air pump.

Electrical connection:

For operating the *Turbo* Chalk reactor you need an electrical supply and a simple timer. Please control the voltage of the electrical components (pump, Chalk reactor control) with the voltage of the supply! Connect the *Turbo* Chalk reactor pump and the *Turbo* Chalk reactor control unit to the timer. Air inlet and water inlet should run all the time.

For optimal efficiency please program the timer with a short brake after two hours. In the break time all foreign gases like oxygen and nitrogen will go out off the reactor.

The probe connector (9) is for installing a pH sensor. It will measure the pH of the internal water. The pH should be about 5.0 to 5.5.

Putting into operation

Please read this part carefully to prevent work and failures. Incorrect use of the reactor may destroy the circulation pump.

1. Be sure that all inlets and outlets are connected (incoming water, out coming water, air and CO₂)
2. Close ball valve 14 and open ball valves 13 and 15. Start the water inlet pump, open the water inlet ball valve (5) and fill the reactor completely with water. Put the *Turbo* Chalk Reactor circulation pump (8) into operation for a short time to bring out the air off the pump. **This step is important to minimize the work.** Only if all air is out of the pump it can produce the pressure for the calcite bed. Maybe you have to wait for half a minute and start the pump again. If all air is out off the system, stop the pumps and drain the reactor half.
3. Open the calcite tube (2). Take off the cap of the calcite tube and take out the upper filter sieve (11).
4. Fill up the calcite tube to the maximum filling mark (upper edge of the label). Do not use more or another material. Otherwise the system does not work correctly. Close the calcite tube - don't forget

the upper sieve (11)! Please use AquaCare *Turbo Granules* – it is the most effective material. With others the efficiency will fall down drastically.

5. Close ball valve 14 and open ball valves 13 and 15. Open the water inlet ball valve (5), start the incoming pump, and fill the reactor with water completely! To fill up the calcite tube completely sometimes it is necessary to start the circulation pump for a very short time.

6. Now start the air supply. For the right volume, see technical data. Every time you must see bubbles in the sediment tube (4).

7. Open ball valve 13-15 and start the pump (8).

8. Reduce the pressure ball valve (15) that only the very small *Turbo Granules* at the top will be in motion. Heavy movements of the Granules will cause turbidity in the aquarium.

9. Reduce the incoming water (5) to the optimum. For the right volume, see technical data.

10. Start the CO₂ supply carefully. If the *Turbo Control* is mounted the solenoid will start after some seconds. Open the needle valve at the pressure relief valve carefully. You see the incoming bubbles at the bottom of the CO₂ tube. The needed bubbles per time depends on the water inlet flow, the pH in the reactor and if the *Turbo control* is mounted.

11. Reduce the ball valve (13) to the CO₂ tube carefully. The water should flow down as fast as possible. But small CO₂ bubbles should never reach the bottoms of CO₂ tube. If foam will occur in the CO₂ tube the ball valve (13) has to be opened a little bit more. If you cannot open the ball valve (13) further and the downstream in the CO₂ tube is too less you can increase the water flow by reducing the bypass ball valve (14).

The right volumes for incoming water, air and CO₂

Water Inlet:

The power of the *Turbo Chalk Reactor* should be controlled by the daily operation time. Do not reduce the incoming water! Otherwise the circulation pump will be damaged. The pump for the incoming water should be in operation 24 hours per day. (If it is not in operation the reactor would not be de-aerated within the brakes.)

The optimum incoming water for the AquaCare *Turbo Chalk Reactors*:

Size 4	Size 5
40...50 l/h	80...100 l/h
10...13 US gal / h	21...26 US gal / h

Please take this optimum volumes. If the water in the reactor becomes **yellow** and very turbid, the incoming water must be raised. Otherwise the circulation pump gets a damage. For raising the incoming water please open the ball valve (5) in the inlet. If the ball valve is totally open, please take a larger incoming pump.

The air supply for the neutralizing tube:

The more air comes into the neutralizing tube the higher the pH of the out coming water (maximum pH 7,3). The air supply should be in action all the time. The proper function of the air pump should be controlled in the sediment tube - every time you must see bubbles in the sediment tube.

If the pH of the out coming water (not the internal water at the probe connector) is higher than 7,3 you have to reduce the air input. If the pH is below 7,0 you must force the air input (use a stronger pump).

The right CO₂ volume WITHOUT *Turbo Control*:

Please regulated the CO₂ volume that after the operation time of the reactor any CO₂ will be sucked by the circulation pump. But after the operation time a big CO₂ bubble should be in the CO₂ tube. If too less CO₂ is in the reactor, the system will not work properly. Attention! At the beginning the reactor needs much CO₂ – at the end of an operation period the system needs less CO₂.

The right CO₂ volume WITH *Turbo Control*:

We recommend a *Turbo control* for reactors larger than size 3!

If a control is mounted you need more CO₂ volume. If you start the reactor and the control (timer ON) the solenoid will start after some seconds. Please raise the CO₂ volume per time that the control will shut off the CO₂ input after 1-2 minutes after the start. If the *Turbo Chalk Reactor* needs more CO₂ the solenoid will start again automatically.

Important! If the incoming CO₂ bubbles will not reach the top of the CO₂ tube you have to lower the water flow inside the CO₂ tube by throttling valve 13 and/or opening valve 14. Otherwise the CO₂ sensor will be fooled.

It is possible to reduce the ball valve (13) to the CO₂ tube if the water in the CO₂ tube contains many very small bubbles (foam). If these fine bubble occur the control will not work properly.

The power of the *Turbo Chalk Reactor*:

Important!!! The power of the *Turbo Chalk Reactors* should be controlled with the operation time. Do not lower or raise the water inlet! Maximum power is reached with two hours operation - 15 minutes pause - two hours operation.... For a normal reef aquarium you need 2 - 6 hours operation time per day. If the aquarium contains very many living hard corals the operation time can raise up to 20 hours. For the first two months control the carbonate hardness (alkalinity) every week. The optimum is between 8 and 12°dH (German hardness) or 2.8 to 4.3 mval. The reactor may produce a light turbidity in the aquarium. It is pure calcium carbonate and it is not dangerous. To prevent the turbidity, take some very fine filter material at the outlet of the water.

To control the daily operation time please use a simple timer. **With this timer control the circulation pump and the CO₂ supply. Air supply and incoming water should operate 24 hours a day. Please start with a low operation time (2 hours per day). The power of the AquaCare *Turbo Chalk Reactor* is very high compared to other systems!**

Carbonate hardness should not be below 5°dH (alkalinity 1.8), the calcium concentration not below 400 mg/l (ppm). KH above 15°dH (alkalinity 5.3) and calcium above 500 mg/l (ppm) can cause negative effects in the reef aquarium. If only one parameter is to low, raise it with other compounds, e.g. AquaCare Care System „KH-plus“ or Super Buffer, „Calcium-plus“ or calcium hydroxide solution „Kalkwasser“. Ensure that the magnesium concentration is optimal.

The maximum carbonate hardness and calcium concentration depends on the pH of the aquarium water. Normally you can reach 10°dH and 400 mg/l calcium. The average pH of the aquarium would raise a little bit after some days operation of the reactor. If the pH of the aquarium is too high reduce the air volume of the neutralizing tube.

Maintenance

To have an optimum system you must do some maintenance work. Otherwise the power is not high or some parts may damage.

Daily control of water inlet: measure the incoming water or use a volume meter or estimate the water inlet in the inspection glass.

Daily de-aeration of the reactor: for de-aerating the reactor you have to stop the circulation pump minimum once a day (or use a simple timer) - without stopping the incoming water. - After 2-15 minutes all gases are out of the reactor.

Weekly to monthly: fill up the calcite tube with *Turbo Granules*. Stop the circulation pump and the CO₂ supply. Open the calcite tube (2), take out the upper filter sieve (11), wash it out and fill up the calcite tube. The material dissolves totally with the time - you only fill new material to the old. You never change the material.

If the sediment tube is full: stop the system, disassemble the tubes from the sediment tube (B, C), take the tube from the mounting plate, open the tube at the cap and clean it. Assemble the system after cleaning.

Every year: clean the neutralizing tube, change the air stone (12) and clean the CO₂ sensor. If the pump gets loud: change the impeller. Use only the original impeller (see technical data).

Some tips

Take some **vaseline** for the **threads** of the tubes. It is more easier to open them.

Take some **vaseline** for all **O-rings** to have gas tight connections.

Reduce the power of the reactor if carbonate hardness is more than 15°dH (5.3 mval) or calcium more than 500 mg/l (ppm). You can save electrical power, CO₂ and spare parts.

The reactor should **start** minimum **once a day**. Otherwise the calcite material may block.

Turbidity in the aquarium water can stop after using a fine filter material in the outlet of the reactor or by reducing the circulation water flow (valve 13).

You can **save CO₂** if you stop the CO₂ supply ½ to 1 hour before stopping the circulation pump (you need a second timer).

If the air supply would be not in order the out coming water of the reactor is too low (5.2-5.5). To prevent damage in the aquarium use a pH control. If the pH in aquarium is below e.g. 7.9 the AquaCare reactor should stop totally.

Warranty

You have 24 months warranty on all AquaCare units excepts spare parts like air stones, pump parts and granules. You have no warranty if parts are broken by violent (for example totally closed water inlet). If you send a warranty unit to AquaCare please send the dated receipt, too.

Technical data

Size	4	5
Order number	310-004us	310-005us
Max. aquarium volume in litres	7000	1000
Max. aquarium volume in US gallons	1800	2500
Sizes (W×H×D) in mm	490 × 1100 × 230	490 × 1400 × 230
volume granules in ccm	5000	7800
maximum / average power 3h/d operation time per day in litres * hardness	20000 / 2500	40000 / 5000
typical daily operation time	1-6 hours (best operation in the evening)	
pH value outlet	7.3	
build in pump	EHEIM 1260	
electrical power of pump in watts	65	
EHEIM order number of spare rotor do not use another one!!!	7653068	
connection inlet / outlet	6 mm / 10 mm	
water inlet flow in l/h	40...50 at 1.5 m	80...100 at 1.5 m
Water inlet flow in US gal/h	11...13 at 1.5 yard	21...26 at 1.5 yard
volume meter	15...150 (option)	15...150 (in series)
air volume in l/h	400 at 300 mbar	500 at 300 mbar
CO ₂ supply	CO ₂ pressure tank, pressure release valve and needle valve; 0.5 to 5.0 bar	
CO ₂ -control for <i>Turbo Chalk Reactor</i> (optional)	order number: 312-001 control box 7 watts with 120 volt AC solenoid valve incl. Fittings, check valve; CO ₂ -sensor with 3/4" connection and mounting material	

www.aquacare.de