

Contents

Contents

	page
New Instruments	4 - 5
VARION	4
IQ SENSOR NET radio module MIQ/Blue PS	5
IQ SENSOR NET System 182 XT	5
Parameter Section	6 - 53
Dissolved Oxygen	6 - 12
pH/ORP	13 - 21
Conductivity	22 - 27
Turbidity/Suspended Solids	28 - 33
Nitrogen	34 - 45
Phosphate	46 - 49
Carbon: COD/TOC/DOC/SAC/BOD	50 - 53
Systems/Accessories	54 - 105
Monitors	
EcoLine/QuadroLine®	54 - 57
IQ SENSOR NET	58 - 75
Analyzer	76 - 81
Sample Preparation	82 - 85
Samplers	86 - 93
Accessories	94 - 103
Measuring Stations	104 - 105
General Information	106 - 112
Overview	
“Laboratory and Field Instrumentation”	106 - 107
WTW – About us	108 - 109
Index	113

Publisher



Wissenschaftlich-Technische Werkstätten GmbH

Dr.-Karl-Slevogt-Straße 1

D-82362 Weilheim

Germany

Tel: +49 (0) 881 183-0
+49 (0) 881 183-100

Fax: +49 (0) 881 183-420

E-Mail: Info@WTW.com

Internet: <http://www.WTW.com>

Analog

Monitors
EcoLine/QuadroLine®
and Sensors

- High accuracy and enhanced EMC performance using integrated pre-amplifier
- Integrated lightning protection
- EcoLine 170:
Monitors for field installation
- QuadroLine® 296:
Monitors for panel mounting
96 x 96 mm

D.O.
pH
Cond
Turb

NH_4

NO_3

NO_2

Analyzer

TresCon®/
TresCon® Uno

- TresCon®: Multi-parameter analyzer for up to three parameters
- Self-calibrating systems: easy to use – easy to extend
- Also available as a compact single parameter unit



Digital

Multiparameter System

IQ SENSOR NET

System 182 (XT), 184 XT
and 2020 XT

TSS

NH₄

NO₃

COD

TOC

DOC

SAC

BOD

P_{Total}

PO₄



- One system for all parameters
- High accuracy and enhanced EMC performance using – integrated pre-amplifier & digital processing
- Integrated lightning protection
- Sensor can be pre-calibrated in Lab
- Universal sensor connection – Standard for all digital sensors
- Easily expandable using 2-wire technology
- 0/4 ... 20 mA
RS 232, RS 485, PROFIBUS-DP, Modbus RTU





New VARiON Instruments

Ammonium and Nitrate on-line:

reliable and cost-effective, directly in the process

NEW

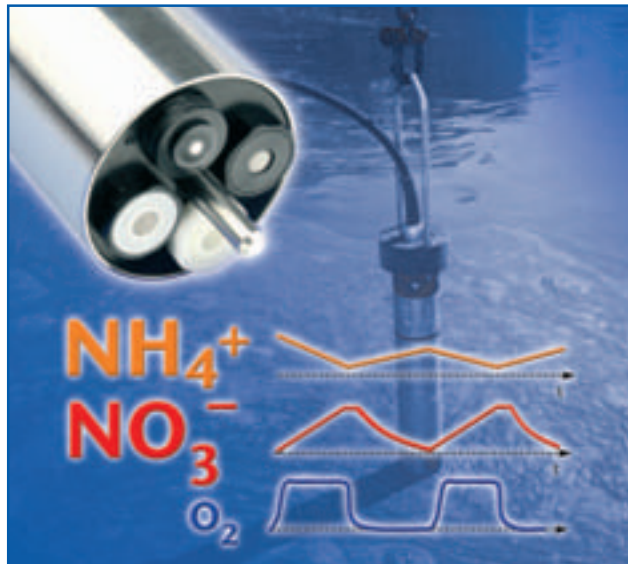

Nitrification and denitrification control with ...

the new combination sensor VARiON 700 IQ

for cost-effective and efficient control of nitrogen elimination in wastewater purification by means of a direct in-process measurement allowing a prompt detection of changes

- **Two parameters in one sensor:**
Ammonium and nitrate measurement - simultaneously with one sensor
Fast and directly in the process
- **Fully automatic compensation of interference ions:**
Reliable measurement for control purposes
Compensation of possible interference ions by means of a built-in ion-selective electrode
- **Low investment and operating costs:**
No sample transportation and processing required
Easy handling of sensor

Do you need an additional D.O. or suspended solids measurement? The multi parameter system IQ SENSOR NET makes it easy for you: Just connect the sensor, everything else is done automatically.



New Instruments

IQ SENSOR NET

New Instruments

IQ SENSOR NET "goes wireless"!

NEW

with the new MIQ/Blue PS SET

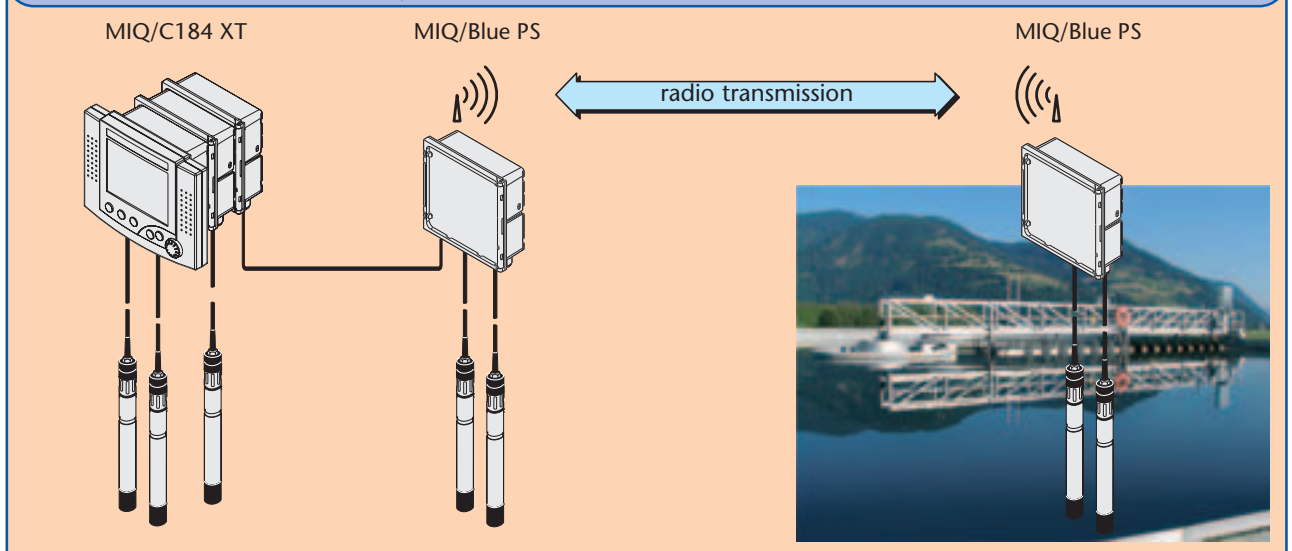

THE solution if a cable connection is not possible or too complex:

- For all IQ SENSOR NET systems
- Full functionality on both sides (including integrated mains adapter and connection facility for the sensors)
- Power supply via solar panel or battery
- Easy installation by pre-configured SETs – ready to use

Integration of a measuring point in the post-sedimentation tank with revolving scraper bridge.

IQ SENSOR NET System 182 XT
with 4 analog outputs and 5 relays

NEW

This compact two-channel monitor is suited for you especially if:

- Two sensors are to be connected
- And if additional analog outputs are required, e.g. for temperature

Application examples:

- Inlet of a wastewater treatment plant with pH/conductivity and temperature measurement
- Two aeration tanks located at close quarters, each with one D.O. and one temperature measurement

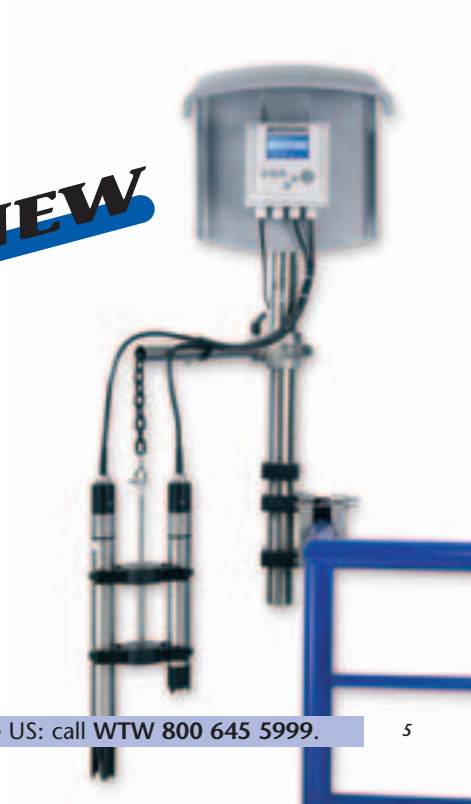



Oxygen

On-Line Dissolved Oxygen Measurement

Measuring · Monitoring · Controlling

- Water / Wastewater Treatment
- Water Pollution Control
- Aquaculture



Reliable and continuous measurements of dissolved oxygen have become of vital importance in many areas of the water/ wastewater treatment facilities. The availability of accurate and timely measured concentration values is an absolute need for process monitoring and dynamic process control to ensure an efficient plant operation.

For more than 50 years now, WTW has been recognized as a leader in the field of Dissolved Oxygen measurements. Innovative technologies, creative and continuous product development, and extensive application expertise have resulted in superior instruments and systems of outstanding performance, reliability and design for the most precise online measurements available.



Dissolved Oxygen Measurement

D.O. Monitoring and Control

In the biological nutrient removal process of wastewater treatment plants, continuous and precise measurement of dissolved oxygen concentration is of vital importance to an optimal and trouble free operation of the water/wastewater treatment facility. The efficiency of the purification process, either in the nitrification and denitrification phase, is mainly determined by the performance of the aeration control system; i.e., by a load-rate controlled oxygenation in the aeration basin.

In the presence of dissolved oxygen, the nitrifying bacteria convert ammonia to nitrate. The activity of the microorganisms depend on the oxygen concentration, with an economical limit at about 2 mg/l. Higher oxygen concentrations do not increase the rate of degradation.

NH₄-N Degradation Rate vs. D.O. Concentration

Degradation Rate

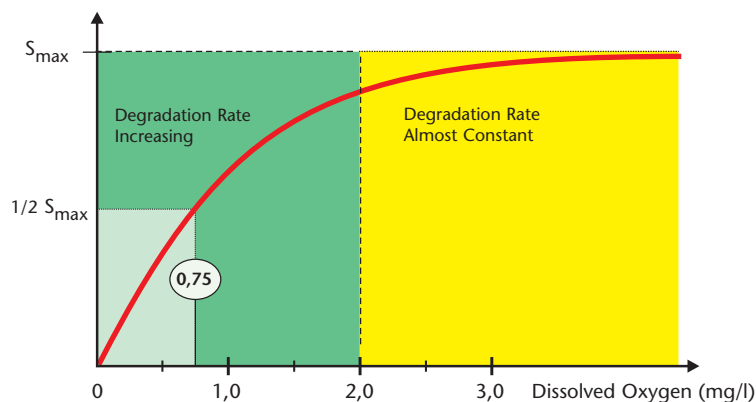

Controlling the aerator operation to a minimum run time, depending on the required oxygen concentration, helps in saving energy and maintenance costs. This is because the aerator equipment is the most energy consuming part of a biological wastewater treatment plant.

The residual dissolved oxygen in the sludge, however, has a negative effect on the conditions in the denitrification stage. For this reason, a minimal D.O. concentration is desirable but which, on the other hand, is sufficient for a total nitrification in the activated sludge. Only the use of precise and reliable on-line measuring instruments will ensure an efficient and energy saving control of the process.

WTW D.O. Measurement Systems

WTW has been continuously designing, manufacturing and satisfying the demands for reliable dissolved oxygen measurements with the most advanced online systems available anywhere.

The WTW product line includes a wide range of precision D.O. sensors and monitors as well as the revolutionary IQ SENSOR NET system so that the optimum system configuration can be chosen for the particular application.



TriOxymatic® Oxygen Sensors

The ECDO: proved and tested...

ECDO

stands for **Electrochemical Dissolved Oxygen Sensor**. 50 years ago, Clark's cell was introduced and WTW was among the first manufacturers to advance this principle for water and wastewater applications. Today, WTW's DO measuring technology is considered the standard in water analysis.

High accuracy

WTW sensors feature extremely low maximum errors of 1% of the measured value (i.e. 0.02 mg/ml at a measured value of 2 mg/ml), regardless of whether measuring in the upper or in the lower range of the instrument.

No replacement of the membrane cap

No regular replacement of the membrane cap is required. (At most, this may be required after several years of operation, depending on process conditions.)

Maintenance-free due to special membrane

The membrane or the membrane cap plays a decisive role in all DO measuring techniques. Fouling or mud covering of the membrane or of the cap will affect the measurement reading. Unlike conventional membranes, e.g. silicone etc., the teflon membranes used by WTW are highly resistant to fouling. This allows operation without the use of additional cleaning accessories in most cases.

Self-check for safe operation

All relevant parts such as the membrane are monitored for damage and defects by the sensors' diagnostics are displayed. No regular visual inspections or preemptive replacements of the membrane caps are required.





Dissolved Oxygen Sensors

Stable readings right from the start

All WTW ECDOs provide stable and reproducible readings right from the start:

- No break-in
- No long-term drift
- No zero point drift due WTW's patented TriOxmatic® principle.

The Best News

WTW's ECDO technology has been thoroughly proven in 20 years of field use: More than 20,000 installations can be found in reliable operation worldwide.



Practical experience... ...put into practice

Perfected technology

Optimum immunity to interference

High level of accuracy and immunity to interference through built-in preamplifier. Its active electronics, located directly in the sensor, process the sensitive sensor signal on-site and convert it into a low impedance signal, which is immune to interference.

Integrated lightning protection

The highly efficient, built-in lightning protection device provides reliable protection to the sensor and transducer against high energy impulses often released by lightning strikes.

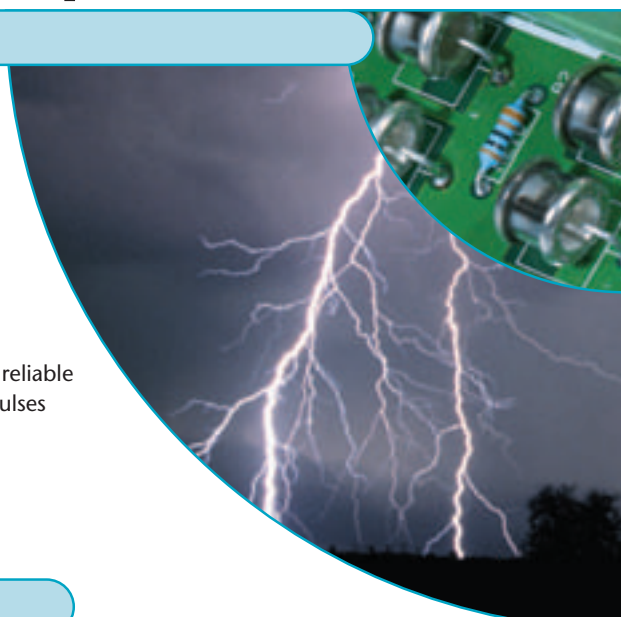

Patented Technology

3-electrode system

In contrast to conventional membrane covered oxygen sensors equipped with 2-electrode technology, the TriOxmatic® sensor functions with a potentiostatically driven 3-electrode system. In terms of measuring technology, this means that the measuring system has two silver electrodes and a gold cathode (A). One silver functions as a non-current bearing reference electrode (R). And, the other is the live, counter electrode (G). The reference electrode thus displays significantly improved potential constancy, which in turn leads to considerably improved sensor signal stability and thus higher measuring accuracy.

The 3-electrode technology additionally allows precise monitoring of the electrolyte supply, i.e. the system displays when the electrolyte solution needs to be replaced.

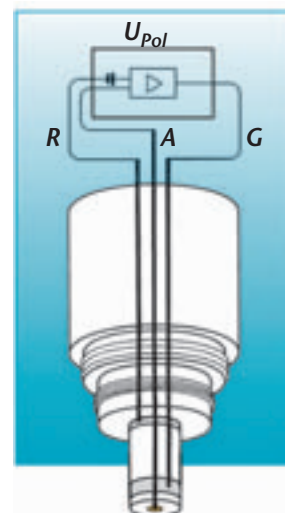



IQ Sensor connection

TriOxmatic®

To optimally satisfy the various requirements for a wide range of wastewater and water applications, the TriOxmatic® Series offers the choice of several D.O. sensors with different operating specifications. All models are based on the potentiostatic 3-electrode principle (except TriOxmatic® 700 IN) and have the same reliability and precision; however, their resolutions, response times and required flow rates are adapted to suit different applications.

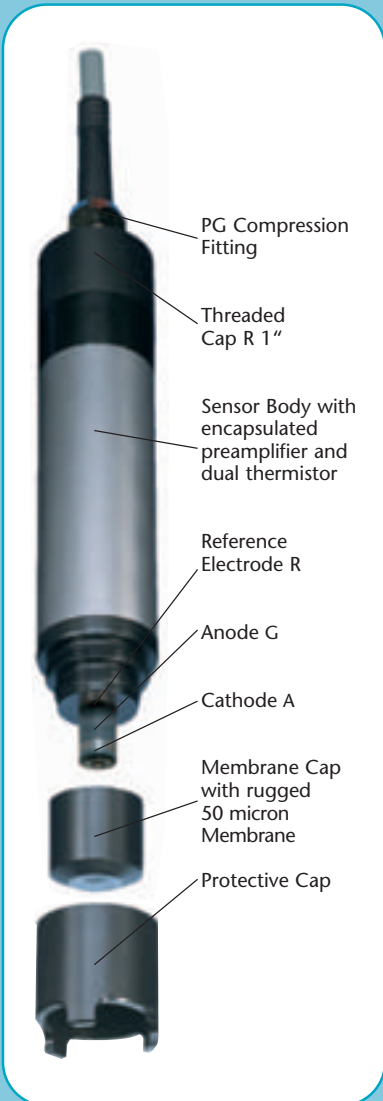

PG Compression Fitting

Threaded Cap R 1"

Sensor Body with encapsulated preamplifier and dual thermistor

Reference Electrode R

Anode G

Cathode A

Membrane Cap with rugged 50 micron Membrane

Protective Cap

IP 68

UL
CUL

2 Years
Warranty

Analog

TriOxmatic® 700/700 IN

The standard Model TriOxmatic® 700 is a rugged dissolved oxygen sensor with a very durable 50 micron thick hydrophobic membrane, a minimal flow rate of 0.5 cm/sec and a medium response time of less than 180 sec. With these features, this membrane sensor is ideally suited for any D.O. measurement in biological purification stages of municipal waste water treatment plants; e.g. **control of the oxygenation**. The response of the sensor prevents signal disturbances due to rising air bubbles thus eliminating false readings and improved stability. This is specially important for measurements in aeration tanks.

TriOxmatic® 690

This cost-effective D.O. sensor offers the same specifications and features as the Model TriOxmatic® 700, except it does not have the sensor monitoring function. This unit is primarily designed for conventional D.O. measurements, where a continuous membrane check is not needed; e.g. general applications in water quality analysis.

TriOxmatic® 701

Equipped with a special 25 micron thick membrane, the Model TriOxmatic® 701 features an enhanced resolution and a faster response time. This sensor is ideally suited for low level concentration applications; e.g. measurements of **residual oxygen** in the **denitrification** of biological sewerage treatment.

Digital

TriOxmatic® 700 IQ

Universal oxygen sensor for **measuring and controlling oxygen input in biological sewage treatment processes in wastewater treatment plants**. Membrane, flow rate and response times equivalent to TriOxmatic® 700, however as digital sensor with calibration value memory for connection to IQ SENSOR NET.

TriOxmatic® 701 IQ

O₂ sensor with increased resolution and improved response times. Technical specifications equivalent to TriOxmatic® 701, however as digital sensor with calibration value memory for connection to IQ SENSOR NET.

TriOxmatic® 702 IQ

Providing similar performance data as the TriOxmatic® 701, the 702 IQ model is specifically designed for trace level measurements in the ppb range. This sensor is ideally suited for use in ultra-pure water applications; e.g. monitoring of boiler feed water or drinking water purification. The applied digital technology permits integrated storage of calibration values and simple connection to IQ SENSOR NET.



Dissolved Oxygen Sensors

Analog

Digital

Technical Data

TriOxmatic®	690/700 (SW*)/700 IN	701	700 IQ (SW*)	701 IQ	702 IQ
Measuring Ranges (25 °C) O ₂ concentration	0.0 ... 60.0 mg/l	0.00 ... 20.00 mg/l 0.0 ... 60.0 mg/l	0.0 ... 60.0 mg/l	0.00 ... 20.00 mg/l 0.0 ... 60.0 mg/l	0 ... 2000 µg/l 0.00 ... 10.00 mg/l
O ₂ saturation	0 ... 600% (depending upon the selected monitor model)	0.0 ... 200.0% 0 ... 600%	0 ... 600 %	0.0 ... 200.0 % 0 ... 600 %	0 ... 110 %
Resolution O ₂ concentration	0,1 mg/l	0,01 mg/l 0,1 mg/l	0.1 mg/l	0.01 mg/l 0.1 mg/l	0.001 mg/l 0.01 mg/l
O ₂ saturation	1%	0,1 % 1%	1%	0.1% 1%	0.1%
Response time at 25 °C	t ₉₀ : 180 s	t ₉₀ : 30 s t ₉₉ : 90 s	t ₉₀ : 180 s	t ₉₀ : 30 s t ₉₉ : 90 s	t ₉₀ : 30 s t ₉₉ : 110 s
Minimum flow rate	0.05 m/s	0.23 m/s	0.05 m/s	0.23 m/s	0.3 m/s
SensCheck	SensLeck (700/700IN) SensReg (700/700 SW)	SensLeck SensReg	SensLeck SensReg	SensLeck SensReg	– SensReg
Signal output	Analog	Analog	Digital	Digital	Digital
Sensor memory for calibration values	–	–	Yes	Yes	Yes
Power consumption	–	–	0.2 Watt	0.2 Watt	0.2 Watt
Temp. measurement	Integrated NTC, 23 ... 122 °F (-5 °C ... +50 °C)		Integrated NTC, 23 ... 140 °F (-5 °C ... +60 °C)		
Temp. compensation	32 ... 122 °F (0 °C ... +50 °C)		32 ... 140 °F (0 °C ... +60 °C)		
Maximum pressure	10 bar		10 bar (incl. sensor connection cable)		
Ambient conditions	Operating temperature: 32 ... 122 °F (0 °C ... +50 °C) Storage temperature: 32 ... 122 °F (0 °C ... +50 °C)		Operating temperature: 32 ... 140 °F (0 °C ... +60 °C) Storage temperature: 23 ... 149 °F (-5 °C ... +65 °C)		
Electrical connections	Integrated PU connecting cable with fitted 7-pole screw connector (IP 65)		2-wire shielded cable with quick fastener to sensor		
Input power	Powered by WTW D.O. monitor		Powered by IQ SENSOR NET		
Transient voltage protection	Yes		Yes		
EMI/RFI Conformance	EN 61326 class B, FCC Class A		EN 61326 class B, FCC Class A Intended for indispensable operation		
Certifications	CUL, UL		CE, cETLus		
Mechanical	Membrane head assembly, locking cap: POM Sensor body: 316 Ti stainless steel Protection rating: IP 68		Membrane head assembly, locking cap: POM Sensor body: 316 Ti stainless steel Protection rating: IP 68		
Dimensions (length x diameter)	7.83 x 1.57 in. (199 x 40 mm) SW: 8.90 x 2.34 in. (226 x 59.5 mm)		14.17 x 1.57 in. (360 x 40 mm), incl. connection thread of SACIQ sensor connection cable; SW: 14.17 x 2.34 in. (360 x 59.5 mm)		
Weight	Approx. 1.46 lb (660 g); SW: approx. 1.90 lb (860 g)		Approx. 1.46 lb (660 g, without sensor connection cable); SW: approx. 2.58 lb (1.170 g)		

* SW: Sensor in sea water design (with plastic armouring (POM))

Ordering Information

		Order No.
TriOxmatic® 700-7	D.O. sensor for water/wastewater; oxygenation determination; cable length 23 ft. (7.0 m)	201 670
TriOxmatic® 690-7	Same as model 700-7, but without SensCheck function; cable length 23 ft. (7.0 m)	201 690
TriOxmatic® 701-7	D.O. sensor for water/wastewater; oxygenation/residual oxygen determination; cable length 23 ft. (7.0 m)	201 678
TriOxmatic® 700 IN-7	D.O. sensor for highly polluted industrial wastewater; cable length 23 ft. (7.0 m)	201 695
TriOxmatic® 700 IQ	D.O. sensor for water/wastewater; oxygenation determination	201 640
TriOxmatic® 701 IQ	D.O. sensor for water/wastewater; oxygenation/residual oxygen determination	201 644
TriOxmatic® 702 IQ	D.O. sensor, ppb measuring range; ultrapure water/boiler feedwater	201 646
SACIQ-7,0	Sensor connection cable for all IQ sensors, cable length 23 ft. (7.0 m)	480 042
Further cable lengths and special seawater/brackwater designs see brochure "Product Details"		

For information visit www.WTW.com for a customer care center near you or inside US: call WTW 800 645 5999.

Parameter section

Dissolved Oxygen

pH/ORP

Conductivity

Turbidity/
Suspended Solids

Nitrogen

Phosphate

Carbon:
COD/TOC/DOC/
BOD/SAC



Configuration Guide

		Oxi 170 Field Monitor	Oxi 296 Panel Mount	IQ SENSOR NET Systems 182/184 XT/2020 XT
		1. Measuring Ranges 2. Response Time t_{90} 3. SensCheck Function		
Analog	TriOxmatic® 690 D.O. sensor for water/wastewater	1.: 0.0 ... 60.0 mg/l 0 ... 600 % 2.: < 180 s 3.: –	<ul style="list-style-type: none"> • Low-cost system without sensor diagnostic • Water/wastewater • Oxygenation 	—
	TriOxmatic® 700 D.O. sensor for water/wastewater	1.: 0.0 ... 60.0 mg/l 0 ... 600 % 2.: < 180 s 3.: SensLeak SensReg	<ul style="list-style-type: none"> • Water/wastewater • Oxygenation 	—
	TriOxmatic® 700 IN D.O. sensor for water/wastewater with permanent polarization	1.: 0.0 ... 60.0 mg/l 0 ... 600 % 2.: < 180 s 3.: SensLeak	<ul style="list-style-type: none"> • Industrial wastewater • Oxygenation 	—
	TriOxmatic® 701 D.O. sensor for water/wastewater	1.: 0.00 ... 20.00 mg/l 0.0 ... 60.0 mg/l 0.0 ... 200.0 % 0 ... 600 % 2.: < 30 s 3.: SensLeak SensReg	<ul style="list-style-type: none"> • Water/wastewater • Oxygenation • Residual D.O. 	—
Digital	TriOxmatic® 700 IQ D.O. sensor for water/wastewater	1.: 0.0 ... 60.0 mg/l 0 ... 600 % 2.: < 180 s 3.: SensLeak SensReg	—	<ul style="list-style-type: none"> • Water/wastewater • Oxygenation
	TriOxmatic® 701 IQ D.O. sensor for water/wastewater	1.: 0.00 ... 20.00 mg/l 0.0 ... 60.0 mg/l 0.0 ... 200.0 % 0 ... 600 % 2.: < 30 s 3.: SensLeak SensReg	—	<ul style="list-style-type: none"> • Water/wastewater • Oxygenation • Residual D.O.
	TriOxmatic® 702 IQ Trace Level D.O. Sensor	1.: 0 ... 2000 µg/l 0.00 ... 10.00 mg/l 0 ... 110 % 2.: < 30 s 3.: SensReg	—	<ul style="list-style-type: none"> • ppb measuring range • Ultrapure water • Boiler feedwater

— Not Applicable



pH/ORP On-Line pH/ORP Measurement

pH/ORP Measurement

Measuring · Monitoring · Controlling



pH is one of the most important analysis parameters measured throughout the water, wastewater and many process industries. In the biological treatment of wastewaters, for example, the acidic or alkaline condition of the mixed liquor has an essential influence on the activity of the microorganisms; i.e., continuous on-line pH control is required. Precise and reliable systems for pH monitoring and control are also necessary in drinking water plants and in a variety of industrial process technologies.

Over the last 50 years, WTW have been designing and manufacturing precision systems for pH measurement. Ongoing research and development coupled with innovative ideas have resulted in novel methodologies and sophisticated products that have set technological milestones time and time again. WTW's technical expertise and long experience in this field are the reason that our on-line pH instruments are now recognized for their excellent performance, reliability and product quality.

-  Wastewater Treatment Facilities
-  Water Treatment Utilities
-  Neutralization Plants
-  Surface Waters and Groundwater
-  Food Industry
-  Chemical Production
-  Industrial Processes



Neutralization/Precipitation/Detoxification



Both in water and wastewater treatment and also in industrial processes pH is of great practical importance. The acidity or alkalinity of a process medium plays a key role in many chemical or biological reactions as well as in mechanical/ physical actions. A number of reactions – in precipitation and detoxification, for example – may only take place if the pH condition is properly controlled. A “misadjusted” pH can cause a variety of serious effects, of which corrosion is the most common. Therefore, at a low or high pH **neutralization** treatment often is required.

In the area of **municipal and industrial wastewater** treatment extreme pH conditions may result in the following harmful effects:

- Microorganisms in biological purification processes are sensitive to acidic and alkaline conditions. Therefore, the pH of the sewage is supposed to be in the neutral range of pH 7. At pH levels of less than 5 or larger than 10 the activity of the bacteria practically ceases.
- pH values of 6.5 and lower result in gradual destruction of metallic materials and mechanical components, and even in damage of the sewer network.
- The solubility of many substances varies with the pH level and temperature. Undesirable and obstructive precipitation of solids may be the result.

Today's legislative regulations and environmental directives in many countries already require that trade effluents may only be discharged into municipal sewer systems if the pH is between 6.5 and 8.5. For this reason, industrial dischargers, for instance, breweries and dairies, often have to pretreat its effluent in a **neutralization** plant.

pH Control System

Neutralization, precipitation and detoxification not only require continuous pH measurement but also an efficient **pH control system**. In less demanding applications, such as stable processes with slowly changing conditions, a simplified 2-point logic control may be adequate. In many cases, however, a proportional control loop is considerably more efficient and also economical with regard to dosing of flocculants or neutralization chemicals.

pH measuring technology by WTW



WTW's complete line of pH/ORP instrumentation comprises sensor assemblies, monitors and system components for a wide range of applications.

In addition to the well proven SensoLyt® sensor assemblies, which are widely used in wastewater facilities, the product line includes ruggedized sensor assemblies for in-line measurements in industrial processes.

The proven monitors of the 170 and 296 series have a PIF control algorithm. A special measuring transducer as well as sensors and accessories are available for use in explosion-proof areas (see brochure “Product Details”).

The IQ SENSOR NET and the IQ sensors open up a whole new realm of technology with features such as an immense degree of flexibility and “sensors which can be pre-calibrated in the laboratory”.



SensoLyt[®]

pH/ORP

Sensor Systems

pH/ORP Measurement

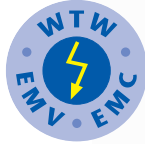

SensoLyt[®] 700







SensoLyt[®] 700 IQ

SensoLyt[®] System Design

For continuous pH/ORP measurement, especially under the difficult conditions very often found in sewage treatment facilities, very high demands are made concerning the reliability and operating safety of the systems employed. For more than three decades, WTW's field-proven pH/ORP measuring systems can satisfy these requirements to the fullest.

Designed specifically for these harsh applications, the SensoLyt[®] sensors are precision engineered assemblies, which consist of a submersible housing with a built-in preamplifier and the appropriate combination pH or ORP electrode. In combination with our high-performance monitors, the sensors constitute an integrated, extremely reliable pH/ORP measuring system which represents the highest standard, state-of-the-art technology with regard to accuracy, EMC noise immunity and economy.

The digital technology of the IQ sensors, which can store calibration values directly in the sensor, offer particular advantages. This feature allows the user to calibrate the sensor in the laboratory and then return it to its location of use. Its sensor's quick coupler permits direct reintegration into the system.

-  Low interference
-  Sensor check function for glass breakage detection
-  Robust mechanical design
-  Simple change of pH electrode
-  Pre-calibration of sensor possible (SensoLyt[®] 700 IQ)
-  Combination electrodes for diverse applications

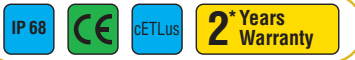

*on armature



IQ Sensor connection

Sensolyt® Combination Electrodes

The reliability of pH and ORP measurements are determined to a large extent by the quality of the pH/ORP electrode which commonly is exposed to extreme conditions; particularly in many industrial applications. With its special design, WTW Sensolyt® combination electrodes are superior to conventional electrodes in terms of failures and durability.

The design of the applied reference system used is crucial to the overall performance of an electrode. In Sensolyt® combination electrodes the reference is a conventional Ag/AgCl/Cl electrode system, completely embedded in a pressure resistant solid gel-polymer electrolyte. As concentration changes in gel-type electrolyte occur very slowly, i.e. the electrochemical characteristic of the cell is unchanged, a stable and constant reference potential will be achieved.

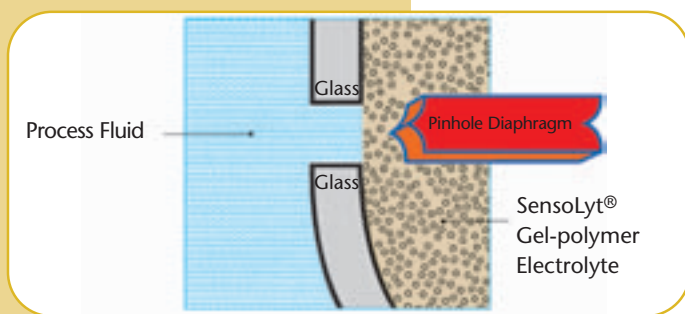

With this electrode design, the polymer matrix/process fluid interphase consists of a pinhole diaphragm; i.e. an electrical flux is established through two fine holes in the cell of the reference system. Such a diaphragm especially reduces the risk of failures.

In addition, Sensolyt® combination electrodes require very little maintenance as there is no electrolyte replacement.



Sensolyt® SEA-HP

Sensolyt® SEA / SE*

This pressure and temperature resistant combination pH electrode incorporates a double pin-hole diaphragm and a gel polymer solid electrolyte, which is AgCl free and therefore resistant to sulfides. This pH electrode is specially designed for use in moderately to highly polluted municipal and industrial wastewater.

Measuring range: pH 2 ... 12

- Highly contaminated sewage
- Emulsions and suspensions
- Media containing proteins and sulfides

Sensolyt® SEA-HP

Analog Sensolyt® SEA version, with optimized armoring for use under high pressure / temperature conditions.

Measuring range: pH 4 ... 12

- Inline measurement in pipes

Sensolyt® DWA / DW*

The DWA pH electrode is specially suitable for drinking water measurements. Its long service life and precise measurement make it stand out from the crowd, in particular for measurements of drinking water with low conductivity.

Measuring range: pH 0 ... 14

- Drinking water

Sensolyt® ECA / EC*

This combination pH electrode has a single pin-hole diaphragm and a gel electrolyte. With its long-term stability it provides an economical solution, particularly in most wastewater facilities.

Measuring range: pH 2 ... 12

- normally polluted wastewater

Sensolyt® PtA / Pt*

Similar to the Sensolyt® SEA regarding its design features and electrochemical characteristics, the Sensolyt® PtA is a combination ORP electrode. It is also fitted with a pinhole diaphragm, and is primarily recommended for applications in heavily contaminated wastewater.

Measuring range: ± 2000 mV

- Municipal and industrial sewage
- Emulsions and suspensions
- Media containing proteins and sulfides

* electrode without armor
for direct use in flow-thru vessels



SensoLyt® Sensor Assemblies

SensoLyt® sensor assemblies perform multiple functions:

- **preamplification** of the electrode signal
- holder for an integrated NTC sensor for **temperature measurement**
- reliable **protection** of the installed pH-electrodes against mechanical damage
- Digital signal processing with calibration value storage (IQ sensors)

The very low voltage signal delivered by the pH/ORP electrode is very susceptible to noise and ground-loop interferences. For this reason WTW has integrated a pre-amplifier in the sensor assemblies. Its amplification and impedance conversion assure low-impedance and thus reliable signal transmission over long distances; e.g. required for operation with remotely installed monitors. In addition, electrical isolation of the preamplifier prevents influences from external field potentials.

SensoLyt® sensor assemblies feature a built-in NTC thermistor for temperature measurement and automatic temperature compensation. This enables both pH or ORP and temperature to be measured simultaneously with a single probe.

Under the rigorous operating conditions of an industrial plant, e.g. a wastewater treatment plant, the rugged design of the housing provides important mechanical protection of the glass pH electrode. For service purposes, the electrode can be replaced in the field without tools.

pH/ORP Measurement

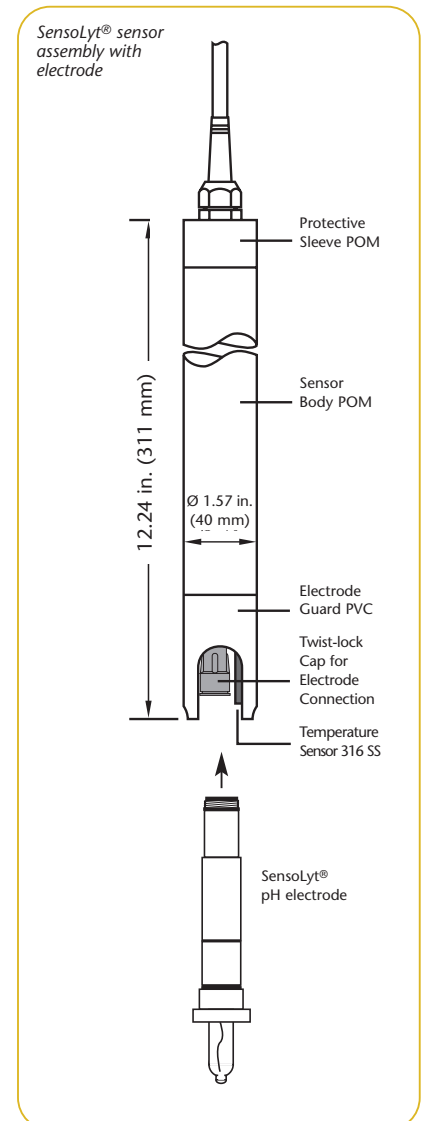
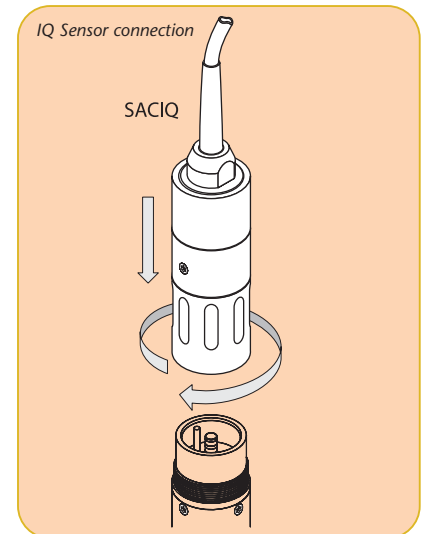

Analog

SensoLyt® 700

The SensoLyt® 700 standard assembly incorporates an integrated preamplifier and a built-in stainless steel NTC sensor. When using a WTW monitor, a special circuitry allows the pH electrode to be monitored for glass breakage. In addition, the SensoLyt® 700 offers as a standard feature an efficient lightning protection system. The SensoLyt® 700 sensor assembly can be fitted with any combination electrode of the SensoLyt® series. It is compatible with all WTW monitors of the EcoLine and QuadroLine® Series.

SensoLyt® 690

Same as SensoLyt® 700, but without the SensCheck function.

SensoLyt® 650

The SensoLyt® 650 unit is a passive assembly without preamplifier; i.e., it is designed for "high-impedance operation" with the electrode connected directly to the monitor input. The assembly is directly compatible with the high-impedance input of following WTW monitors: pH 170 and pH 296 models.

Digital

SensoLyt® 700 IQ

Digital pH/ORP armature with integrated preamplifier and lightning protection as well as digital signal processing and integrated temperature probe for connection to an IQ SENSOR NET. A special circuiting permits glass breakage detection monitoring. Due to the integrated calibration value memory, a "pre-calibrated pH measurement", the value of which is stored in the sensor, can be set in the laboratory. The sensor's quick release coupling allows the user to remove it from the location of use and return it after successful calibration in the laboratory. With an IQ connection in the laboratory, inconvenient field calibration under adverse conditions can be completely eliminated.



Technical Data SensoLyt® Sensor Assemblies

SensoLyt®	700 (SW*)	690	650	700 IQ (SW*)
Integrated Pre-amplifier	Yes	Yes	No	Yes
Signal output	Low impedance, analog	Low impedance, analog	High impedance, analog	Digital
Sensor check function	Yes	No	No	Yes
Sensor memory for calibration values	–			Yes
Power consumption	–			0.2 Watt
Temperature measurement	Integrated NTC, 32 ... 140 °F (0 ... +60 °C)			Integrated NTC, 23 ... 140 °F (-5 ... +60 °C)
Ambient conditions	Operating temperature: 32 ... 140 °F (0 ... +60 °C)			Operating temperature: 32 ... 140 °F (0 ... +60 °C)
Electrical connections	integrated PU connecting cable with fitted 7-pole screw connector (IP 65)		Integral PU connecting cable with bare cable ends	2-wire shielded cable with quick fastener to sensor
Transient voltage protection	Yes			Yes
EMI/RFI Conformance	EN 61326 class B, FCC Class A			EN 61326 class B, FCC Class A Intended for indispensable operation
Certifications	CUL, UL			CE, cETLus
Mechanical	Sensor body: POM Protective cap: PVC Protection rating: IP 68			Sensor body: 316 Ti stainless steel Protective cap: PVC Sensor holder: POM Protection rating: IP 68
Dimensions (L x D)	12.24 x 1.57 in. (311 x 40 mm); SW: 15.52 x 2.34 in. (318 x 59.5 mm)			20 x 1.57 in. (508 x 40 mm); SW: 20.78 x 2.34 in. (515 x 59.5 mm)
Weight (without cable)	Approx. 0.71 lb (320 g); SW: approx. 1.94 lb (880 g)			2.14 lb (970 g); SW: approx. 3.97 lb (1.800 g)

*SW: Sensor in sea water design (with plastic armouring (POM))

Technical Data SensoLyt® Combination Electrodes

	SEA / SE*	SEA-HP	DWA / DW*	ECA / EC*	PtA / Pt*
Electrode type	Gel-polymer solid electrolyte double pinhole diaphragm		Modified gel electrolyte ceramic diaphragm	Gel electrolyte single pinhole diaphragm	Gel-polymer solid electrolyte double pinhole diaphragm
Operating conditions (Overpressure/temperature)	10 bar/68 °F (20 °C) 1 bar/140 °F (60 °C) 32...140 °F (0...60 °C)	10 bar/140 °F (60 °C) 32...140 °F (0...60 °C)	6 bar / 68 °F (20 °C) 1 bar / 140 °F (60 °C) 32 ... 140 °F (0 ... 60 °C)	6 bar / 68 °F (20 °C) 1 bar / 140 °F (60 °C) 32 ... 140 °F (0 ... 60 °C)	10 bar / 68 °F (20 °C) 1 bar / 140 °F (60 °C) 32 ... 140 °F (0 ... 60 °C)
Measuring range	2 ... 12 pH	4 ... 12 pH	0 ... 14 pH	2 ... 12 pH	±2000 mV
Mechanical	Cylindrical glass membrane, armored version with PVC armouring (SEA-HP: POM), 2 Viton O-ring seals for mounting into SensoLyt® sensor assemblies				
Dimensions	Length 4.72 in./120 mm (without plug head)				
Electrical connections	Watertight plug head connector				
	* Electrode without armor, e.g. for direct use in flow-thru vessels			** Depending on monitor	

Ordering Information pH/ORP Sensors

	Order No.
Analog sensors	
SensoLyt® 700-7	pH/ORP sensor with integrated preamplifier; cable length 23 ft. (7.0 m) 109 191
SensoLyt® 690-7	Same as model 700-7, but without SensCheck function 109 180
SensoLyt® 650-7	pH/ORP sensor for high impedance operation; cable length 23 ft. (7.0 m) 109 195
Digital sensors	
SensoLyt® 700 IQ	pH/ORP sensor for combination electrodes SensoLyt® SEA, DWA, ECA, PtA 109 170
SACIQ-7,0	Sensor connection cable for all IQ sensors, cable length 23 ft. (7.0 m) 480 042
Combined electrodes	
SensoLyt® SEA	pH combination electrode, measuring range 2 ... 12 pH, for mounting into SensoLyt® sensor assemblies 109 115
SensoLyt® SEA-HP	pH combination electrode, measuring range 4 ... 12 pH, for mounting into SensoLyt® sensor assemblies 109 118
SensoLyt® DWA	pH combination electrode, measuring range 0 ... 14 pH, for mounting into SensoLyt® sensor assemblies 109 119
SensoLyt® ECA	pH combination electrode, measuring range 2 ... 12 pH, for mounting into SensoLyt® sensor assemblies 109 117
SensoLyt® PtA	ORP combination electrode, measuring range ± 1000 mV, for mounting into SensoLyt® sensor assemblies 109 125
SensoLyt® SE	Same as model SEA, but without armor; e.g. for direct use in flow-thru vessels 109 100
SensoLyt® DW	Same as model DWA, but without armor; e.g. for direct use in flow-thru vessels 109 103
SensoLyt® EC	Same as model ECA, but without armor; e.g. for direct use in flow-thru vessels 109 102
SensoLyt® Pt	Same as model PtA, but without armor; e.g. for direct use in flow-thru vessels 105 412
Further cable lengths, special design (e.g. for seawater) and buffer solutions see brochure "Product Details"	



pH In-line Measurement

InTrac® 777-SLM

Valve Assembly for Sensor Insertion/Retraction

pH In-line Measurement



- Installation in pipes or pressure vessels
- Complete separation of the process fluid from the environment
- Sensor locking device as safeguard
- Pressure resistant electrode with polymer electrolyte

For many years InTrac® valve assemblies have been successfully used for in-line pH measurement in industrial process applications. The devices are designed for installation in pipes or vessels, and permit manual insertion and retraction of the pH sensor without interrupting the process flow. InTrac® assemblies offer an enhanced reliability and safety for use under tough process conditions; e.g., measurement in pressure vessels.

The InTrac® 777M is a high-performance valve assembly which meets the increasingly stringent requirements of the industrial practice. In particular, the device satisfies the high safety criteria currently set for process equipment by using a state of the art technology. In combination with WTW monitors the InTrac® sensor valve assembly provides versatile and integrated pH measurement systems for a variety of industrial applications.

The manually operated InTrac® valve assembly is available in a robust stainless steel construction, all wetted parts are made of stainless steel 1.4404/316 L. Thus, the valve assembly is operable at pressures of up to 16 bar and at temperatures of up to 291.2 °F (140 °C). Manual insertion and retraction of the sensor is only possible at pressures of up to 6 bar (effort).

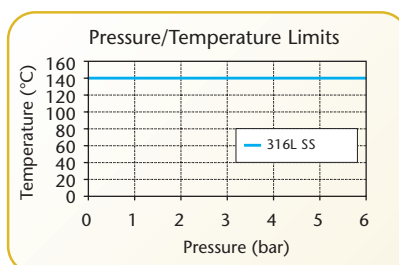



XEROLYT® Combination pH Electrode



HA 405-DXK-S8/225 InPro 4250/225/Pt100

The InTrac® 777M valve assembly is fitted with combination pH electrodes with a XEROLYT® reference system. Using a polymer electrolyte, this system is superior to conventional design with gel- or paste-type electrolytes with regard to operating reliability and working life. The twist-lock connector allows easy cable connection and simple electrode replacement.

- Electrode with double pinhole diaphragm
- Very low maintenance, because of polymer electrolyte: no electrolyte refilling required
- Especially suitable for polluted or solutions containing sulfide
- Electrode with built-in temperature sensor available

InPro 4250/225/Pt100

pH electrode with built-in temperature sensor and VARIOPOL plug connection

System compatibility

The pH combination electrodes are connected directly to the high-impedance input of the model pH 170 and pH 296 monitors with the suitable connection cable. If there is a long distance between the measuring point and the monitor then the KI/pH 170 terminal box must be included. This ensures low-impedance interference-free signal transmission to the monitor (not in combination with InPro 4250). The terminal box also allows the connection of a temperature sensor if automatic temperature compensation is required.

Electrodes for InTrac® 777-SLM

HA 405-DXK-S8/225

pH electrode without temperature sensor; with S8 plug head connection

Technical Data XEROLYT® pH Combination Electrodes

	HA 405-DXK-S8/225	InPro 4250/225/Pt100
Measuring range	pH 2 ... 14	pH 0 ... 14
Operating Temp.	32 ... 230 °F (0 ... 110 °C)	32 ... 266 °F (0 ... 130 °C)
Temperature sensor	–	Pt 100
Electrode type	Polymer electrolyte containing KCl, double pinhole diaphragm	Polymer electrolyte containing KCl, double pinhole diaphragm
Max. pressure range	16 bar / 77 °F (25 °C); 6 bar / 212 °F (100 °C)	16 bar / 77 °F (25 °C); 8 bar / 266 °F (130 °C)
Length	8.86 in. (225 mm)	8.86 in. (225 mm)
Connection	S8 plug head / IP67	VP plug / IP 67

Technical Data InTrac® 777M Sensor Valve Assembly

Construction	Positioner/Valve assembly for manually retracting/inserting XEROLYT® pH combination electrode; wetted materials PVC or stainless steel
Insertion depth	2.76 in. (70 mm)
Body material	POM
Wetted parts	1.4404: 316 L stainless steel
Solution chamber	Inlet/outlet: 2 x G 1/8"; 1 x G 1/4"; Pressure range: 2-6 bar

Ordering Information

Sensor Valve Assembly		Order No.
InTrac® 777M/070/4404/D00/Vi/A00	Manually operated valve assembly, wetted material 316 L stainless steel	109 222
Sensors		Order No.
HA 405-DXK-S8/225	Combination pH electrode for InTrac® 777-SLM models	109 226
InPro 4250/225/Pt100	pH combination electrode for InTrac® 777-SLM models, with built in Pt100 temperature sensor	109 231
Connecting cables and accessories see brochure "Product Details"		



Configuration Guide

		pH 170 Field Monitor	pH 296 Panel Mount	IQ SENSOR NET Systems 182, 184 XT and 2020 XT
Analog	Sensolyt® 650 Sensor Assembly w/o preamplifier, high-impedance output, integrated temp. measurement, 32...122 °F (0...50 °C)	Compatible electrodes: SEA: 2...12 pH SEA-HP: 4...12 pH DWA: 0...14 pH ECA: 2...12 pH PtA: ±1000 mV 32...140 °F (0...60 °C)	<ul style="list-style-type: none"> • Low-cost configuration • High impedance signal transmission • pH measurement in highly polluted wastewater (municipal/industrial) Type SEA • pH measurement in normally polluted wastewater (municipal/industrial) Type ECA • pH measurement in drinking water (DWA) • ORP measurement in highly polluted wastewater (municipal/industrial) Type PtA • Inline installation (SEA or SEA-HP) 	—
	Sensolyt® 690 Sensor Assembly w/ integrated pre-amplifier, low-impedance, output, integrated temp., measurement 32...122 °F (0...50 °C)	Compatible electrodes: SEA: 2...12 pH SEA-HP: 4...12 pH DWA: 0...14 pH ECA: 2...12 pH PtA: ±1000 mV 32...140 °F (0...60 °C)	<ul style="list-style-type: none"> • Low-cost configuration • Low impedance signal transmission • pH measurement in highly polluted wastewater (municipal/industrial) Type SEA • pH measurement in normally polluted wastewater (municipal/industrial) Type ECA • pH measurement in drinking water (DWA) • ORP measurement in highly polluted wastewater (municipal/industrial) Type PtA • Inline installation (SEA or SEA-HP) 	—
	Sensolyt® 700 Sensor Assembly w/ integrated pre-amplifier, low-impedance output, integrated temp. measurement 32...122 °F (0...50 °C) and SensorCheck	Compatible electrodes: SEA: 2...12 pH SEA-HP: 4...12 pH DWA: 0...14 pH ECA: 2...12 pH PtA: ±1000 mV 32...140 °F (0...60 °C)	<ul style="list-style-type: none"> • Low impedance signal transmission • SensCheck • pH measurement in highly polluted wastewater (municipal/industrial) Type SEA • pH measurement in normally polluted wastewater (municipal/industrial) Type ECA • pH measurement in drinking water (DWA) • ORP measurement in highly polluted wastewater (municipal/industrial) Type PtA • Inline installation (SEA or SEA-HP) 	—
	InTrac® 777M/070/4404/D00/Vi/A00 Valve assembly with flushing for cleaning and calibration Material: 316 L SS 16 bar / 284 °F (140 °C)	Compatible electrodes: InPro 4250/225/Pt100 0...14 pH 32...266 °F (0...130 °C) HA 405-DXK-S8 2...14 pH 32...230 °F (0...110 °C)	<ul style="list-style-type: none"> • High impedance signal transmission • In-line pH measurement in process lines or pressure vessels • Increased pressure/temperature requirements 16 bar / 284 °F (140 °C) • Built-in temperature measurement with 4250/225/Pt100 	—
Digital	Sensolyt® 700 IQ with integrated pre-amplifier, integrated temperature measurement 32...140 °F (0...60 °C), SensorCheck and calibration value storage	Compatible electrodes: SEA: 2...12 pH SEA-HP: 4...12 pH DWA: 0...14 pH ECA: 2...12 pH PtA: ±2000 mV 32...140 °F (0...60 °C)	—	<ul style="list-style-type: none"> • Digital signal transmission • SensCheck • pH measurement in highly polluted wastewater (municipal/industrial) Type SEA • pH measurement in normally polluted wastewater (municipal/industrial) Type ECA • pH measurement in drinking water (DWA) • ORP measurement in highly polluted wastewater (municipal/industrial) Type PtA • Inline installation (SEA or SEA-HP)

– Configuration not possible



Conductivity

On-Line Conductivity Measurement

Measuring · Monitoring · Controlling



-  Municipal and Industrial Wastewater
-  Water Treatment
-  Surface Waters
-  Sea Water, Brackish Water
-  Boiler Feed Water
-  Demineralization
-  Industrial Process Media

Conductivity is a well recognized, and sometimes indispensable, parameter of state-of-the-art water, wastewater and industrial process analysis. Continuous measuring systems are employed to monitor the salt load at the influent of wastewater treatment plants, to control quality of drinking water and ultra-pure water or to determine non-specific contaminants in industrial processes.

For almost 60 years, WTW has been one of the leading manufacturers of precision conductivity measurement systems, setting new standards with innovative sensor technology and fully evolved designs tailored to practical applications. WTW products meet the most stringent requirements set by industry for continuous on-line analysis instruments.

A special measuring transducer as well as sensors and accessories are available for use in explosion-proof areas (see brochure "Product Details").



Conductivity Measurement

Conductivity

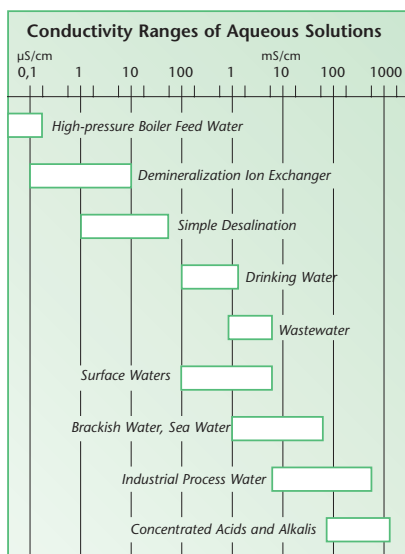

Conductivity as a summation parameter is a measure of the level of ion concentration of a solution. The more salts, acids or bases are dissociated, the greater the conductivity of the solution. In water or wastewater it is mainly a matter of the ions of dissolved salts, and consequently the conductivity is an index of the salt load in wastewater or, respectively, the purity of potable water. The measurement of conductivity is also widely used in industrial production, such as process control in food and pharmaceutical industries.

The measurement of conductivity is generally expressed in S/cm (or mS/cm) which is the product of the conductance of the test solution and the geometric factor of the measuring cell. The scale for aqueous solutions starts at a conductivity of 0.05 μS/cm (at 77 °F/25 °C) for ultrapure water. The conductivity of natural waters, such as drinking water or surface water is typically in range of 100 - 1000 μS/cm. The upper End of the scale is reached by some acids and alkalies.

Temperature Compensation

The conductivity of a solution is critically dependent on temperature. Therefore, the conductivity readings must be referred to a common reference temperature (77 °F/25°C) for comparability. The term "temperature compensation" is used in the sense of a mathematical conversion; i.e. a measured conductivity $\mathcal{K}(\vartheta)$ at any given temperature to the corresponding conductivity value that would be taken at the reference temperature $\mathcal{K}(77\text{ °F}/25\text{ °C})$.

The conductivity of most aqueous solutions varies more or less linearly with temperature ϑ . In these cases, a linear correction function to compensate for the influence of temperature can be used. For example, the correction coefficient for sewage is approx. 2%/K.

If a non-linear relationship exists between temperature and conductivity, (i.e. the coefficient itself varies with temperature) the relationship can as a rule be described in terms of a 4th order polynomial.

WTW monitors automatically calculate the corrected conductivity values based on the selected temperature coefficient. For the compensation of natural water a non-linear function (nLF) (i.e., built-in table for natural water properties) is available.

Conductivity vs. Temperature Function

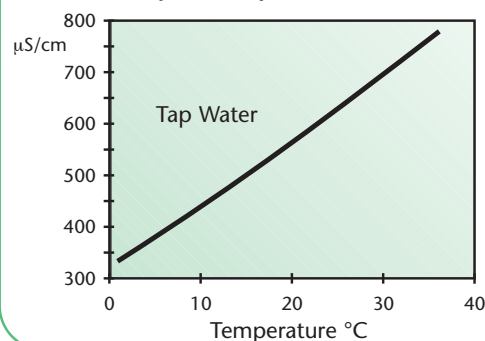



TetraCon[®] 700

Conductivity Cells



- 4-electrode Design
- No polarization effects
- Large measuring range with only a single cell
- Highly resistant to fouling



TetraCon[®] 700 IQ

TetraCon[®] 700/700 IQ

The TetraCon[®] 4-electrode cell from WTW is the perfect result of an application-oriented development. Compared with conventional 2-electrode cells, this advanced design provides substantially better performance, particularly in the higher conductivity ranges.

TetraCon[®] 700 conductivity sensors are especially suitable for use in wastewater treatment plants dealing with highly loaded sewage. Due to the special measuring technique employed, severe influences from primary and secondary polarization effects are eliminated, resulting in improved accuracy of the sensor. Provided the devices are installed in accordance with the manufacturer's instructions, errors due to the distortion of the current and voltage fields are also avoided.

The special cell geometry of the TetraCon[®] 700 makes it impervious to fouling, and the abrasion resistant carbon electrodes are also easy to clean. The modern epoxy resin encapsulation technique used diminishes the likelihood of sensor breakage in harsh industrial environments.

The TetraCon[®] 700 as digital model TetraCon[®] 700 IQ is also available for connection to IQ SENSOR NET. This version is specially featured by a larger measuring range (10 µS/cm ... 500 mS/cm).

IP 68



cETLus

2 Years
Warranty



TetraCon® 4-electrode Design

The conductivity of a given electrolyte is determined by an electro-chemical resistance measurement. In its simplest configuration, the measuring cell uses **two** electrodes to which an alternating voltage is applied. The electric current which is directly proportional to the free ions in the electrolyte is measured. The electronic instrument then calculates the conductivity of the solution, taking into account the absolute cell constant of the sensor.

With the **TetraCon® 4-electrode design**, two separate electrode pairs are used whereby the currentless voltage electrodes produce a stable and constant reference potential. The voltage drop at the current electrodes is regulated via a potentiostat circuit.

The advantage of this technique is that it eliminates measurement errors usually caused by **polarization effects** which most likely build up at higher conductivity levels. Contact resistance problems caused by contaminated electrodes is also largely avoided by this design.

Conductivity Cells

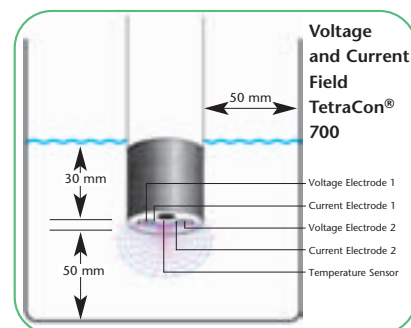

Minimal Distance: 1.97 in. (50 mm)
Minimal Immersion Depth: 1.18 in. (30 mm)

WTW Conductivity Sensors

TetraCon® 700

Rugged conductivity sensor (4-electrode design), with integrated dual thermistor, abrasion resistant carbon electrodes and break-proof epoxy body; measuring range 10 μ S/cm to 1000 mS/cm. Submersible sensor assembly specially designed for use in wastewater treatment plants.

TetraCon® 325

4-electrode conductivity cell with graphite electrodes, integral temperature probe; measuring range 1 μ S/cm - 2000 mS/cm. Suitable for universal applications.

TetraCon® DU/T

4-electrode conductivity cell with integral flow-thru chamber (7 ml volume), built-in temperature sensor; measuring range 1 μ S/cm to 2000 mS/cm. Recommended for standard industrial applications.

TetraCon® 700 IQ

Digital 4-electrode conductivity cell (same as TetraCon® 700). In addition to the general preferences of IQ technology the TetraCon® 700 IQ offers the benefit of a larger measuring range (10 μ S/cm ... 500 mS/cm).



LRD 01

LRD 325

LRD 01

316 Ti stainless steel conductivity cell for installation in pipes. Built-in temperature sensor (266 °F/130 °C max.), measuring range 0.01 to 200 μ S/cm, pressure resistant up to 14 bar, 1/2 inch NPT thread.

LRD 325

Conductivity measuring cell for installation in pipes. With built-in temperature sensor (up to 212 °F/100 °C). Measuring range 1 μ S/cm to 2 S/cm, pressure resistant up to 10 bar. 1/2 inch NPT thread.

LR 325/01

Low-level conductivity cell with flow-thru chamber, integrated temperature sensor; measuring range 0.001 to 300 μ S/cm. For use in ultra-pure water applications; e.g., boiler feed water.

LR 325/001

Like Model LRD 325/01, but with higher resolution; measuring range 0.0001 to 30 μ S/cm. Sensor is especially designed for **trace measurement** in both aqueous and non-aqueous or partially aqueous media.

IP 68

UL CUL

2 Years Warranty



Analog

Digital

Technical Data

Conductivity Cells	TetraCon® 700 (SW**)	LRD 01	LRD 325	TetraCon® 700 IQ (SW**)
Sensor type	4-electrode cell	2-electrode cell	4-electrode cell	4-electrode cell
Measuring range	10 µS/cm ... 1000 mS/cm SAL: 0 ... 70	0.01 ... 200 µS/cm	1 µS/cm ... 2 S/cm	10 µS/cm ... 500 mS/cm SAL: 0 ... 70 TDS: 0 ... 2000 mg/l
Cell constants	K = 0.917 cm ⁻¹ , ±1.5 % (in free solution) K = 0.933 cm ⁻¹ , with EBST 700-DU/N flow-thru adapter	0.1 cm ⁻¹ , ±1.5 %	0.475 cm ⁻¹ , ±1.5%	K = 0.917 cm ⁻¹ , ±1.5 % (in free solution) K = 0.933 cm ⁻¹ , with EBST 700-DU/N flow-thru adapter
Signal output	Analog	Analog	Analog	Digital
Power consumption	—	—	—	0.2 Watt
Temperature sensor	Integrated NTC	Integrated NTC	Integrated NTC	Integrated NTC
Temperature range	32...122 °F (0...+50 °C, ±0.2 K)	32...266 °F (0...+130 °C, ±0.2 K)	32...212 °F (0...100 °C, ±0.2 K)	23...140 °F (-5 °C ... +60 °C)
Maximum pressure	10 bar (at 68 °F/20 °C)	14 bar (at 68 °F/20 °C)	10 bar (at 68 °F/20 °C)	10 bar
Electrical connection	integrated PU connecting cable with fitted 7-pole screw connector	integrated PU connecting cable with fitted 7-pole screw connector	integrated PU connecting cable with fitted 7-pole screw connector (IP 65)	2-wire shielded cable with quick fastener to sensor
Certifications	CUL, UL			CE, cETLus
Mechanical	Sensor head: PVC Body: 316 Ti stainless steel Protection rating: IP 68	Cell body: 316 Ti stainless steel Threaded 1/2 inch NPT Protection/Electrode: IP 68	Measuring cell: epoxy/graphite Thread: 316 Ti stainless steel Protection/Electrode head: IP 68	Sensor head: PVC Body: 316 Ti stainless steel Protection rating: IP 68
Dimensions (length x diameter)	7.72 x 1.57 in. (196 x 40 mm) SW: 8.78 x 2.34 in. (223 x 59.5 mm)	5.24 x 0.98 in. (133 x 25 mm)	5.24 x 0.98 in. (133 x 25 mm)	14.06 x 1.57 in. (357 x 40 mm) incl. connection thread of SACIQ sensor connection cable SW: 14.06 x 2.34 in. (357 x 59.5 mm)
Weight (without cable)	Approx. 1.46 lb (660 g) SW: approx. 1.90 lb (860 g)	Approx. 0.77 lb (350 g)	Approx. 0.66 lb (300 g)	Approx. 1.46 lb (660 g) SW: approx. 2.58 lb (1.170 g)

* useable with monitor 170/296: up to 200 mS/cm

** SW: Sensor in sea water design (with plastic armouring (POM))

Conductivity Cells for Special Purposes

	TetraCon® 325	TetraCon® DU/T	LR 325/01	LR 325/001
Sensor Type	4-electrode cell		2-electrode cell	
Electrode	Carbon	Carbon	316 Ti stainless steel	316 Ti stainless steel
Measuring Ranges	1 µS/cm ... 2 S/cm	1 µS/cm ... 2 S/cm	0.001 µS/cm ... 300 µS/cm	0.0001 µS/cm ... 30 µS/cm
Cell Constant	K = 0.475 cm ⁻¹	K = 0.778 cm ⁻¹	K = 0.1 cm ⁻¹	K = 0.01 cm ⁻¹
Temperature Sensor	Integrated	Integrated	Integrated	Integrated
Flow-thru Measurement	Yes, with additional flow chamber D 201	Yes	Yes, with additional flow chamber D01/T	Yes, with integrated flow chamber
Length	4.72 in. (120 mm)	6.10 in. (155 mm)	4.72 in. (120 mm)	4.72 in. (120 mm)

Ordering Information – Conductivity Cells

		Order No
TetraCon® 700-7	Submersible conductivity sensor for water/wastewater, cable length 23 ft. (7.0 m)	302 316
LRD 01-7	Submersible conductivity sensor for boiler feed water/ion exchanger, cable length 23 ft. (7.0 m)	302 222
LRD 325-7	Submersible conductivity sensor for water/wastewater, cable length 23 ft. (7.0 m)	302 229
TetraCon® 700 IQ	Submersible conductivity sensor for water/wastewater	302 500
SACIQ-7,0	Sensor connection cable for all IQ sensors, cable length 23 ft. (7.0 m)	480 042
Further cable length and special seawater/brackwater designs and accessories see brochure "Product Details"		



Configuration Guide

		1. Measuring range 2. Cell constant 3. Probe type 4. Temperature compensation 5. Temperature range 6. Pressure range 7. Protection rating	LF 170 Field Monitor	LF 296 Panel mount Monitor	IQ SENSOR NET Systems 182/184 XT/2020 XT
Analog	TetraCon® 700	1.: 10 µS/cm..1000 mS/cm 2.: K=0.917 cm ⁻¹ 3.: 4-electrode cell 4.: NTC 5.: 32...122 °F (0...50 °C) 6.: 10 bar 7.: IP 68 (electrode)	Water / Wastewater Usable Measuring Range: 0,0..199,0 µS/cm 0,000..1,999 mS/cm 0,00..19,99 mS/cm 0,0..199,9 mS/cm 32...122 °F (0...50 °C)		—
	LRD 01	1.: 0,01..200 µS/cm 2.: K=0.1 cm ⁻¹ 3.: 2-electrode cell 4.: NTC 5.: 32...266 °F (0...130 °C) 6.: 14 bar (68 °F/20 °C) 7.: IP 68 (electrode)	Boiler Feed Water/Ion Exchanger; In-Line Measurements/ Pipework Mounting 1/2" NPT Thread Usable Measuring Range: 0,00..19,99 µS/cm 0,0..199,9 µS/cm 32...266 °F (0..130 °C); 14 bar (68 °F/20 °C)		—
	LRD 325	1.: 1 µS/cm..2 S/cm 2.: K=0.475 cm ⁻¹ 3.: 4-electrode cell 4.: NTC 5.: 32...212 °F (0..100 °C) 6.: 10 bar 7.: IP 68 (electrode)	Large Usable Measuring Range; In-Line Measurements/ Pipework Mounting 1/2" (3/4" Adapter) NPT Thread 0,0..199,0 µS/cm 0..1999 µS/cm 0,00..19,99 mS/cm 0,0..199,9 mS/cm (MR: 0,0..199,9 mS/cm to 110,0 mS/cm at 122 °F/50 °C) 32...212 °F (0..100 °C); 10 bar at 68 °F (20 °C)		—
	LR 325/01	1.: 0.001...300 µS/cm 2.: K=0.1 cm ⁻¹ 3.: 2-electrode cell 4.: NTC 5.: 32...212 °F (0...100 °C) 6.: 2 bar 7.: IP 68 (electrode)	Boiler Feed Water/Ion Exchanger; Conductivity Cell with Flow-thru Chamber; Usable Measuring Range: 0,00..19,99 µS/cm 0,0..199,9 µS/cm 0,000..0,200 mS/cm 32...122 °F (0..50 °C)		—
	LR 325/001	1.: 0.0001..30 µS/cm 2.: K=0.01 cm ⁻¹ 3.: 2-electrode cell 4.: NTC 5.: 32...212 °F (0...100 °C) 6.: 2 bar 7.: IP 68 (electrode)	Boiler Feed Water/Ion Exchanger; Conductivity Cell with Flow-thru Chamber, Trace Measurements Usable Measuring Range: 0.000..1.999 µS/cm 0.00..19.99 µS/cm 32...122 °F (0..50 °C)		—
	TetraCon® 325	1.: 1 µS/cm..2 S/cm 2.: K=0.475 cm ⁻¹ 3.: 4-electrode cell 4.: NTC 5.: 32...212 °F (0...100 °C) 6.: 2 bar 7.: IP 68 (electrode)	General Application/Water; Large Measuring Range 0.00..19.99 µS/cm 0.0..199.9 µS/cm 0.000..1.999 mS/cm 0.00..19.99 mS/cm 0.0..199.9 mS/cm (32...77 °F/0..25 °C) 32...122 °F (0..50 °C) (MR: 0.0..199.9 mS/cm up to 110.0 mS/cm at 122 °F/50 °C)		—
	TetraCon® DU/T	1.: 1 µS/cm..2 S/cm 2.: K=0.778 cm ⁻¹ 3.: 4-electrode cell 4.: NTC 5.: 32...140 °F (0...60 °C) 6.: 2 bar 7.: IP 65	Flow-thru cell Usable Measuring Range: 0.00..19.99 µS/cm 0.0..199.9 µS/cm 0.000..1.999 mS/cm 0.00..19.99 mS/cm 0.0..199.9 mS/cm 32...122 °F (0..50 °C)		—
	Digital	TetraCon® 700 IQ	1.: 10 µS/cm..500 mS/cm 2.: K=0.917 cm ⁻¹ 3.: 4-electrode cell 4.: NTC 5.: 32...140 °F (0...60 °C) 6.: 10 bar 7.: IP 68 (electrode)	—	—

Parameter section

Dissolved Oxygen

pH/ORP

Conductivity

Turbidity/
Suspended Solids

Nitrogen

Phosphate

Carbon:
COD/TOC/DOC/
BOD/SAC

— Not Applicable



Turbidity and Suspended Solids

Turbidity

- Effluent measurement of sewage treatment plants
- Sludge concentration
- Monitoring / controlling of sludge cycle
- Drinking water

Smell, taste and turbidity are the most important indicators for the quality of potable water.

At the effluent of a waste water treatment plant, turbidity is a quantitative measure of remaining undissolved solids, indicating malfunctions within the treatment process. Turbidity can be measured relatively simple on-line with optical methods. Therefore, turbidity is extremely suitable for measuring the cleaning efficiency of wastewater treatment plants.

Turbidity is typically determined using 90 degree scattered light principle in compliance with EN ISO 7027.

Measuring principle

By the passing of optical radiation through a dispersing system, dispersed solids reduce radiation power by transforming it into another form of energy. This effect is called absorption. The ratio of penetrating to emitting radiation is measured as turbidity.

Factory calibration

The online-sensors from WTW are precisely factory calibrated with a "multi-point" calibration. The calibration is very stable – so further calibration is not needed. Formazine is used as a calibration standard – it is diluted to the necessary concentrations.

Cleaning system

A number of parameters can have a large impact on the measured value and are automatically compensated for. An effective compensation takes into account the influence of a secondary light source, the coloration of particles and the medium. The fouling of the optical path requires an effective cleaning system realised by WTW using a unique Ultrasonic System.

This ultrasonic module, integrated in the VisoTurb® 700 IQ and in the ViSolid® 700 IQ, causes a permanent oscillation on the optical windows avoiding biological fouling.



Optical unit with ultrasonic cleaning system

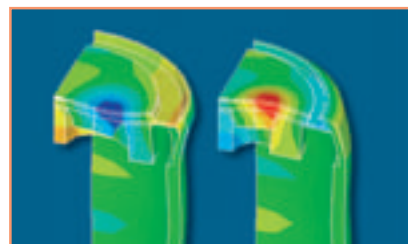

Maximum amplitude at the optical windows



Measurement of Turbidity and Suspended Solids

Pictures show the same sensor with ultrasonic cleaning system switched-off and switched-on in a typical waste water application. The sensor with switched-off cleaning system (left picture) is completely covered with a biological layer. The sensor with working ultrasonic cleaning system (right) shows no adverse effect.

After 16 Days



Sensor without ultrasound cleaning system
After 16 Days



Sensor with ultrasound cleaning system
After 16 Days

Suspended Solids

A continuous gravimetric analysis is not possible in waste water treatment process – therefore indirect methods like turbidity measurement are used. The concentration of suspended solids is a very important process parameter for today's sludge treatment. Total suspended solids can be determined online using scattered light or light absorbance. Under normal conditions there is a good correlation to gravimetric analysis.

For the most important sludge characteristics, WTW has defined so called matrix types – with this stored data, even without customer specific calibration a good correlation to total suspended solids concentrations can be achieved.

However, sludges can be totally different – concerning coloration, particle size and structure. Therefore of course a “multi-point” user calibration is possible. This can be done also with the mandatory required gravimetric determination of total suspended solids.

Application on waste water treatment plants

In order to get a sufficient degree of nitrification, a certain sludge age should not be exceeded. This is significantly influenced by the flow of the surplus sludge and the concentration of TSS in the biological tank measured by the suspended solids sensor. Also the denitrification (N-elimination) and partially the biological P-elimination can be improved by a higher amount of TSS.





Turbidity and Suspended Solids

General Features of Sensors

On-line Turbidity and Suspended Solids Measurement

using revolutionary technology



- New ultrasound cleaning system
- Turbidity Measurement according to EN ISO 7027
- Factory Calibrated
- Long-term stability
- SensorCheck function
- Low Maintenance

Continuous turbidity and suspended solids measurement are of great importance in analytic measurement in modern wastewater treatment plants. Optical infrared scattered light sensors are commonly used for online measurement of this parameter on-site, particularly in the areas of biological wastewater treatment and sludge recycling and in the final effluent of treatment plants.



A clean sensor – prerequisite for reliable measurements

In optical systems, contamination falsifies readings of turbidity or suspended solids by an indeterminate amount. Once contamination of the optical system has begun, further build-up of particles progresses at an accelerated rate. Especially under the extreme conditions that prevail in wastewater treatment plants, the accumulation of microorganisms represents a genuine problem for the otherwise reliable optical measurement method. Therefore, additional manual cleaning is usually indispensable – despite conventional methods of compensation or cleaning using available wiper systems.



General Features of Sensors

VisoTurb® and ViSolid® – new sensors for turbidity and suspended solids measurement

With the **VisoTurb® 700 IQ** and **ViSolid® 700 IQ** sensors, WTW presents a family of optical sensors for turbidity and suspended solids measurement. These sensors incorporate a completely new and innovative ultrasound cleaning system that guarantees low maintenance and long-term reliability of the sensors. Turbidity measurements in aqueous media with VisoTurb® are carried out nephelometrically in compliance with EN ISO 7027. Solid matter measurement with ViSolid® is performed according to the principle of scattered light measurement.

Because of the enormously wide measuring ranges of VisoTurb® (0 – 4000 FNU) and ViSolid® (0 – 300 g/l SiO₂), the best resolution for each measured value can be selected using an AutoRange function. Thus, only two sensors are required to cover almost all applications ranging from drinking water to highly concentrated sludge.

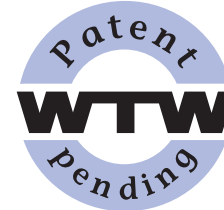

Integrated, wear-free automatic cleaning system

The ultrasound source integrated in the sensor generates high-frequency vibrations of the optical windows in the micrometer range. The maximum vibration amplitudes are at the center of the measurement windows, so that the largest displacement can be found at this location. This prevents accumulation of any kind of contamination from the very start, and thus provides for reliable measurements for continuous operation.

Robust, scratch-proof sapphire measuring window

The sapphire measuring windows are particularly scratch-proof and guarantee accurate measuring results even with permanent use under rough ambient conditions.



Sensor without and with ultrasound cleaning system after 30 days

Extremely low maintenance

- In contrast to traditional sensors equipped with wipers and jutting corners, the exceptionally smooth sensor surface provides a minimum of surfaces on which deposits may accumulate.
- The continuously active ultrasound system inhibits the deposit of all kinds of contamination from the start.
- Thus, the sensor can be operated in a wide variety of applications over several weeks without maintenance.

Thanks to their robust design and the efficient ultrasound cleaning system, **VisoTurb® 700 IQ** and **ViSolid® 700 IQ** are particularly suitable for applications with extreme conditions, e.g. wastewater treatment plants. They provide the user with a very high degree of measurement accuracy at an exceptionally low maintenance rate.



Turbidity Sensor VisoTurb®

Turbidity Measurement according to the Nephelometric Principle

Turbidity Sensor VisoTurb® 700 IQ

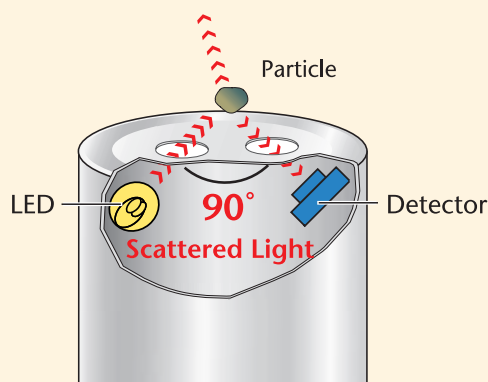

Using this principle, scattered light is measured at an angle of 90 degree. This method is ideal for low and medium range turbidity up to 4000 FNU. In compliance with EN 27027 and ISO 7027, infra red light with a wavelength of 860 nm is used. This wavelength is outside of the visible range – thus potential coloration of the sample does not effect the measurements.

IP 68



cETLus

2 Years Warranty

Technical Data VisoTurb® 700 IQ

Parameter	FNU; NTU; TEF	mg/l SiO ₂ ; ppm SiO ₂	g/l TSS
Measuring range	0.05 ... 4000 FNU	0.1 ... 4000 mg/l SiO ₂	0.0001 ... 400 g/l TSS
Typical applications	Drinking water, surface water, waste water plant: effluent, aeration basin ≤ 3 g / l TSS		
Calibration	Factory calibration with formazine	Factory calibration with SiO ₂	Calibration by user, (TSS regulations in compliance with DIN 38414)
Process variation coefficient according to DIN 38402 part 51	< 1% (in the range up to 2,000 FNU)		
Repeatability according to DIN ISO 5725 or DIN 1319	< 0.015 % or ≥ 0.006 FNU		
Resolution	Automatic according to measuring range 0.001 ... 1 FNU	0.001 mg/l ... 0.01 g/l	0.001 mg/l ... 0.1 g/l
Cleaning System	Ultrasound cleaning system		
SensCheck	Contamination detection of optical window; failure of cleaning system		
Ambient conditions	Operating temperature: 32 ... 140 °F (0 ... 60 °C); ultrasonic cleaning system: 32 ... 104 °F (0 ... 40 °C) (Overheating protection) Storage temperature: 23 ... 149 °F (-5 ... +65 °C)		
Mechanical components	Measurement window: Sapphire Sensor body: V4A stainless steel 1.4571 Schutzart: IP 68		
Pressure resistance	Maximum 10 bar (incl. sensor connection cable)		
Power consumption	5 W		
Dimensions	14.37 x 1.57 in. (365 x 40 mm) (length x diameter), incl. SACIQ sensor connection cable		
Weight	Approx. 2.18 lb (990 g; without cable)		

Ordering Information VisoTurb® 700 IQ

		Order No.
VisoTurb® 700 IQ	Turbidity sensor for water/wastewater with ultrasound cleaning system	600 010
SACIQ-7,0	Sensor connection cable for all IQ sensors, cable length 23 ft. (7.0 m)	480 042



Measurement of Suspended Solids

Suspended Solids Sensor ViSolid®

Measuring Principle of Suspended Solids

With increasing concentration of suspended solids, particles will interfere with each other. With this increasing number, not every particle is reached by the light source or the reflected light is not detected by the receiving device – thus incorrect values are measured. So the 90 degree scattered light method used for the turbidity measurement can only be used for lower concentrations.

For this reason WTW uses two methods of measurement – depending on the concentration. For lower concentrations, a scattered light method is used, in case of higher concentrations, the backscatter method is the better choice.

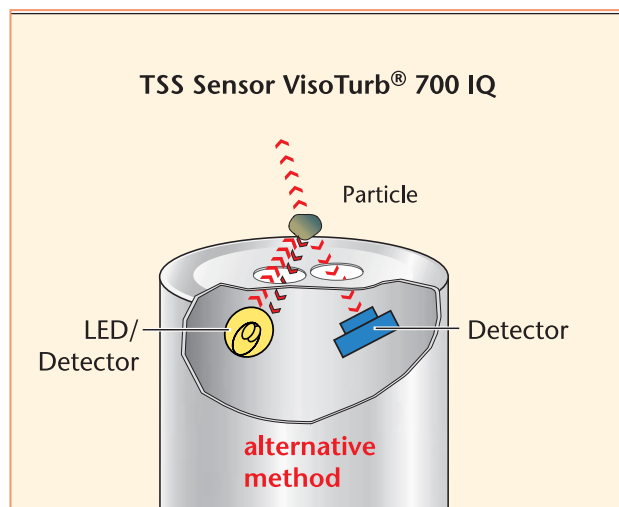

Technical Data ViSolid® 700 IQ

Parameter	g/l SiO ₂ / % SiO ₂	g/l TSS / % TSS
Measuring range	0.01 ... 300 g/l SiO ₂ / 0.001 ... 30% SiO ₂	0.003 ... 1000 g/l TSS / 0.0003 ... 100% TSS
Typical applications	Matrix type 1: aeration basin of waste water plants even with > 3 g / l TSS; return-sludge Matrix type 2: digested sludge	
Calibration	Typical sludge characteristics stored: matrix type 1, matrix type 2 Calibration by user: adjustment via correction factor, 1-point or multi-point calibration possible	
Process variation coefficient according to DIN 38402 part 51	< 2% for matrix type 1, < 4% for matrix type 2	
Resolution	Automatic according to measuring range 0.01 g/l ... 1 g/l	0.01 g/l ... 1 g/l
Cleaning system	Ultrasound cleaning system	
SensCheck	Contamination detection of optical window; failure of cleaning system	
Ambient conditions	Operating temperature: 32 ... 140 °F (0 ... 60 °C) Storage temperature: 23 ... 149 °F (-5 ... +65 °C)	
Mechanical components	Measurement window: Sapphire Sensor body: V4A stainless steel 1.4571 Schutzart: IP 68	
Pressure resistance	Maximum 10 bar (incl. sensor connection cable)	
Power consumption	2 W	
Dimensions	14.37 x 1.57 in. (365 x 40 mm) (length x diameter), incl. SACIQ sensor connection cable	
Weight	Approx. 2.14 lb (970 g; without cable)	

Ordering Information ViSolid® 700 IQ

		Order No.
ViSolid® 700 IQ	Suspended solids sensor for water/wastewater with ultrasound cleaning system	600 012
SACIQ-7,0	Sensor connection cable for all IQ sensors, cable length 23 ft. (7.0 m)	480 042



Nitrogen:

Ammonium · Nitrate · Nitrite

Nitrogen Measurements

Wastewater treatment processes are concerned with controlling the removal of pollutants in the smallest possible space in the shortest possible time.

The efficient control of Nitrogen in wastewater systems is possible by making those measurements directly in the wastewater process. This not only ensures purification but above all guarantees economic operation of the entire plant.

Purification processes for the removal of nitrogen from wastewater

Nitrogen is found in a large variety of compounds and forms and is considered to be the ultimate "quick-change artist". In municipal wastewater it is mainly encountered as a waste product in the form of urea, which is already converted in part to ammonium nitrogen by ammonification.

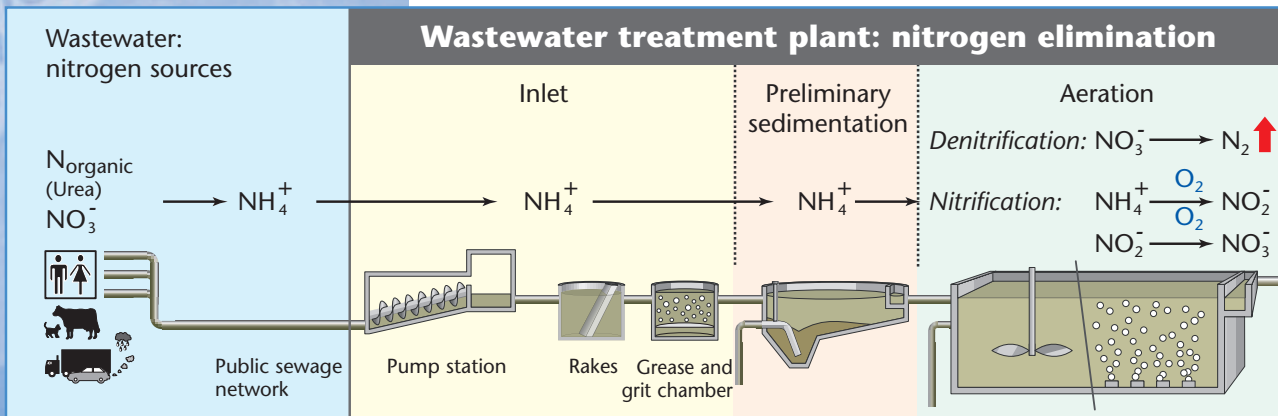

In the aeration basin, the initial step of nitrification consists in oxidizing the nitrogen present in wastewater via nitrite to nitrate, for which oxygen is required. During subsequent denitrification the nitrate (NO_3^-) is further converted to elemental nitrogen N_2 under the absence of oxygen. This nitrogen in gas form is harmlessly released into the environment.

Due to the various framework conditions and different biologically active groups of microorganisms, both methods are conducted in two fundamentally separate processes. The temporal and spatial sequence can be adapted to local conditions.



Measuring method for tracing nitrogen elimination

A common measuring method to date is targeted at oxygen availability. As oxygen is required for nitrification subprocesses, but prevents denitrification, this process parameter is determined online and traced. It is often used for controlling the oxygen input or aerator aggregates.

Redox inflexion point determination has become less significant as an indirect controlled and actuation variable. New direct measuring procedures for the process measuring ammonium and nitrate are far more interesting. The exacting control of the wastewater treatment process is directly optimized. This guarantees efficient wastewater purification – despite the influence of various disturbances. This results in reduced energy costs.

The following example of intermittent procedure illustrates the advantage of direct measurement of selected parameters.

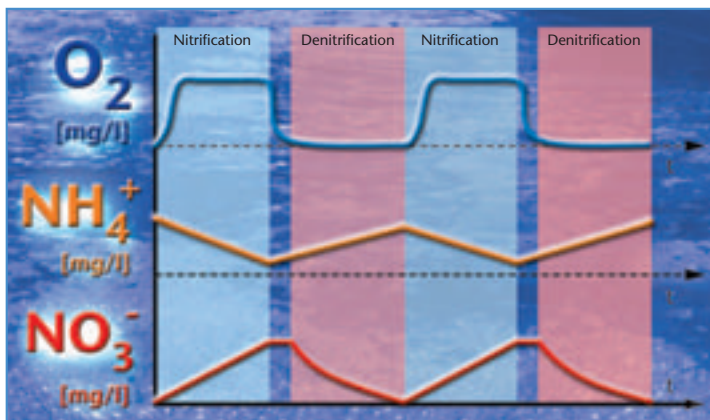

Example: intermittent nitrification/denitrification

Nitrification and denitrification are conducted in succession in the same basin. In the nitrification phase ammonium is oxidized using oxygen to form nitrate and is consumed in the process. The nitrate content increases accordingly. In the denitrification phase nitrate is reduced to form gaseous nitrogen; ammonium is formed from residual organic nitrogen. Ammonium and nitrate curves display opposite behavior.

Correlation between the individual procedure measurements of dissolved oxygen, ammonium and nitrate

In order to minimize energy consumption in the aeration basin, a preferably efficient and low O_2 input should be targeted for complete nitrogen oxidation. Furthermore, the optimum efficiency of denitrification stages with anaerobic or anoxic conditions must be ensured. For optimum growth of nitric bacteria, higher concentrations of dissolved oxygen are generally required than for the pure decomposition of organic carbon compounds. The online measurement of the selected parameter of ammonium, which provides the possibility of NH_4 -N controlled operation, makes the nitrification process transparent and offers significantly higher levels of certainty than in pure O_2 controlled operation. A combined measurement of NH_4 -N and O_2 is suitable for plant operation, as this prevents the formation of bulking sludge in the lower range and limits the oxygen input should interferences occur in NH_4 -N decomposition (e.g. caused by a disturbed nutrient ratio of carbon : nitrogen : phosphate). This can create significant savings potentials.



Direct measuring procedures for determining ammonium and nitrate

The process to be controlled and the measuring system used for decisive control engineering must be able to respond to changes within the process as they occur.

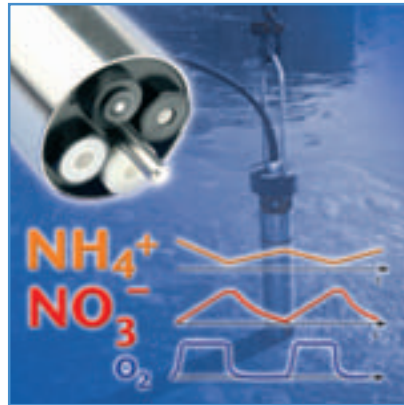

in-situ ISE sensors

These control engineering demands led to the development of **in-situ ISE (ion-selective) measuring techniques**, which are capable of directly recording the respective selected parameter ammonium and nitrate during the process both quickly and without sample preparation. In terms of accuracy, practical compromises can be made.



in-situ UV/VIS probes

in-situ UV/VIS spectrometric probes represent a precise measuring technique with long-term stability, which permit quasi-continuous recording of the selected parameter in the smallest measuring cycles of minutes. The disturbance variables for optical measuring, such as turbidity/suspended solids, are eliminated by spectral recording.



Analyzers

Depending on measurements and applications, **analyzer systems** require standard and reagent solutions as well as sample preparation. Measuring intervals and automatic cleaning cycles are adjustable. These instruments automatically and recurrently compare measurements against reference standards and deliver high precision measurement values.

See page 37 for various measuring systems and applications.

WTW Measuring Systems for Nitrogen

Ammonium

Ammonium and Nitrate

Nitrate



System IQ SENSOR NET
Sensor/Module AmmoLyt® 700 IQ

System TresCon®
Module OA 110
for mounting in TresCon® system

System IQ SENSOR NET
VARION 700 IQ

System IQ SENSOR NET
NitraLyt® 700 IQ

System TresCon®
Modules ON 210/OS 210
for mounting in TresCon® system

System IQ SENSOR NET
NitraVis® 700 IQ

Measured variable
Inlet (determination of load)

Aeration
(regulation and control)

Effluent (monitoring)

Autom. cleaning

Cleaning cycles

Measuring

Sample Preparation

Measuring interval

Response Time

Measuring method

Accuracy

Cross sensitivity

Calibration

Investment costs

Additional costs

Operational costs

Consumables

NH₄ and NO₃

NO₃

NO_x

NO₃

●

●

○

●

●

●

●

●

○

○

●

●

compressed air

variable

in-situ

none

continuous

quick

ISE (ion-selective)

medium

yes, with automatic compensation

manual

low

—

medium

electrodes calibration standard

compressed air

variable

in-situ

none

continuous

quick

ISE (ion-selective)

medium

yes/chloride, compensable

manual

low

—

medium

electrodes calibration standard

cleaning solution

automatic 6/12/24 h after sample preparation

PurCon®/PurCon® Insitu

adjustable

medium

photometric

high

low

automatic 6/12/24 h

medium

sample preparation/pump may be required

low

calibration standard cleaning solution/Wpack

compressed air

prior to each measurement

in-situ

none

adjustable

quick

UV/VIS spectrometric

high

autom. compensated (spectrum)

not necessary

medium

—

none

*Measuring in Aeration

● recommended by WTW ○ conditionally applicable





NEW

Nitrogen VARiON System

Ammonium and Nitrate ion-selective with automatic compensation of interferences

- in-situ combination sensor for ammonium and nitrate
- Automatic compensation of interference ions
- Low investment and operating costs

Possible configurations

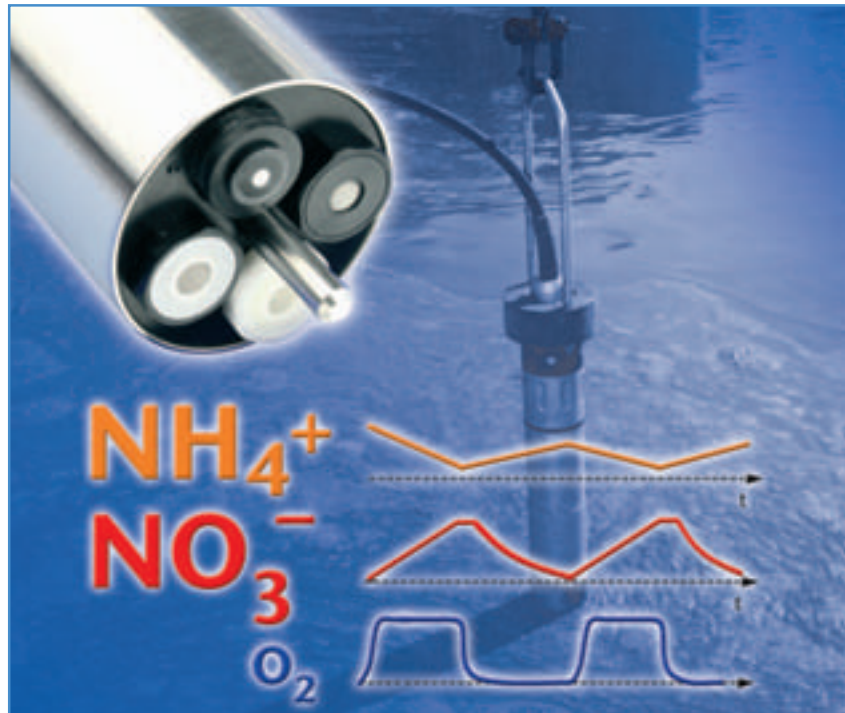
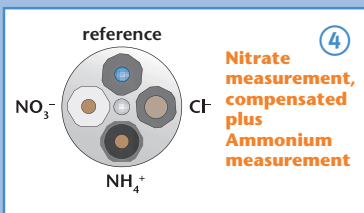
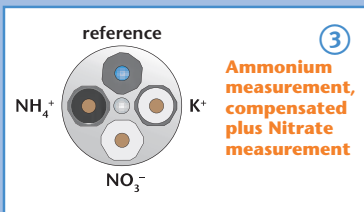
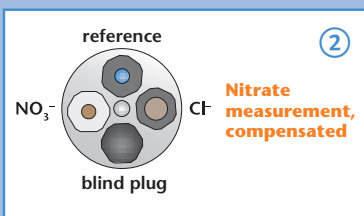
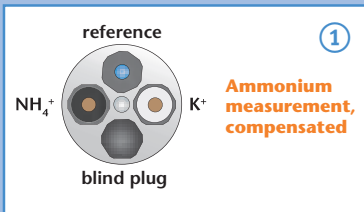

Ion-selective measurements directly in process – reliable 24 hours a day

The new highly variable ionic sensor VARiON allows:

- The continuous measurement of ammonium – with online compensation of potassium ion interference by using potassium ISE.
- On-line compensation for nitrate – chloride as interference ion.
- The third available slot can be used for an additional measuring electrode – this allows a simultaneous measurement of ammonium and nitrate with only one sensor (2 in 1)

For measurement or compensation, simply insert the suitable electrode into

the sensor, everything else is working automatically. The display shows the already compensated values. These values are available via the 0/4–20 mA analog outputs or via the digital output PROFIBUS or Modbus.

The following VARiON variants are available as ready to start sets:

- ① Ammonium measurement, compensated
- ② Nitrate measurement, compensated
- ③ Ammonium measurement, compensated, with additional nitrate measurement
- ④ Nitrate measurement, compensated, with additional ammonium measurement



VARiON System

Technical Data

Maximum Configuration	Common reference electrode, two measuring electrodes, one compensation electrode	
	Ammonium Measurement	Nitrate Measurement
Integrable Electrodes:	VARiON Ref	
Reference Electrode		
Measuring Electrode	VARiON NH ₄	VARiON NO ₃
Compensation Electrode	VARiON K	VARiON Cl
Measuring Ranges/Resolution	NH ₄ -N: 0.1 ... 1000 mg/l / 1 mg/l; 0.1 ... 100 mg/l / 0.1 mg/l NH ₄ ⁺ : 0.1 ... 1290 mg/l / 1 mg/l; 0.1 ... 129,0 mg/l / 0.1 mg/l	NO ₃ -N: 0.1 ... 1000 mg/l / 1 mg/l; 0.1 ... 100 mg/l / 0.1 mg/l NO ₃ ⁻ : 0.5 ... 4500 mg/l / 5 mg/l; 0.5 ... 450.0 mg/l / 0.5 mg/l
Compensation Ranges	K ⁺ : 1 ... 1000 mg/l / 1 mg/l	Cl ⁻ : 1 ... 1000 mg/l / 1 mg/l
Temperature Measurement	Integrated NTC thermistor, Range 32 °F ... 104 °F (0 °C ... +40 °C), Accuracy ±0.5 K, Resolution 0.1 K	
Temperature Compensation	32 °F ... 104 °F (0 °C ... +40 °C)	
Calibration Procedures	2-point-calibration with multiple standard solutions, calibration against any reference value	
Ambient Conditions	Operating temperature: 32 °F ... 104 °F (0 °C ... +40 °C), storing temperature: 32 °F ... 104 °F (0 °C ... +40 °C)	
pH Range	pH 4 ... pH 8.5	pH 4 ... pH 11
Measuring Accuracy in laboratory standard solutions	±5 % of measured value ±0.5 mg/l	
Working Life (typically)	Reference electrode: 6–12 months, ISE electrodes: 4–8 months	
Mechanical	Sensor body: V4A stainless steel 1.4571 Protective cup: POM Temperature sensor: V4A stainless steel 1.4571 Electrode connector: POM Protection rating: IP 68 (0.2 bar, with installed electrodes)	
Max. Pressure	Maximum 0.2 bar (incl. SACIQ sensor connection cable, with installed electrodes)	
Power Consumption	0.2 Watt	
Dimensions	14.45 x 1.57 in. (367 x 40 mm, length x diameter), incl. SACIQ sensor connection cable	
Weight	Approx. 1.76 lb (800 g, without electrodes, without SACIQ sensor connection cable)	

IP 68



CETLus

2* Years Warranty

*on armature

Ordering Information

VARiON SETS	Consisting of probe, reference electrode, measuring and compensation electrodes	Order No.
VARiON A comp SET	Ammonium measurement, compensated	107 060
VARiON N comp SET	Nitrate measurement, compensated	107 062
VARiON AN/A comp SET	Ammonium measurement, compensated, plus nitrate measurement	107 066
VARiON AN/N comp SET	Nitrate measurement, compensated, plus ammonium measurement	107 068
Standard Solutions	For calibration of any VARiON	
VARiON/ES-1	Combined standard 1 (low concentration), 1000 ml	107 050
VARiON/ES-2	Combined standard 2 (high concentration), 1000 ml	107 052
Accessories	For automatic cleaning. Recommended for permanent operation.	
MIQ/CHV PLUS	Valve module for automatic cleaning by compressed air controlled directly via the IQ SENSOR NET bus	480 018
DIQ/CHV	Valve module for automatic compressed air cleaning for System 182; accessible by means of a DIQ/S 182 relay	472 007
CH	Cleaning head	900 107

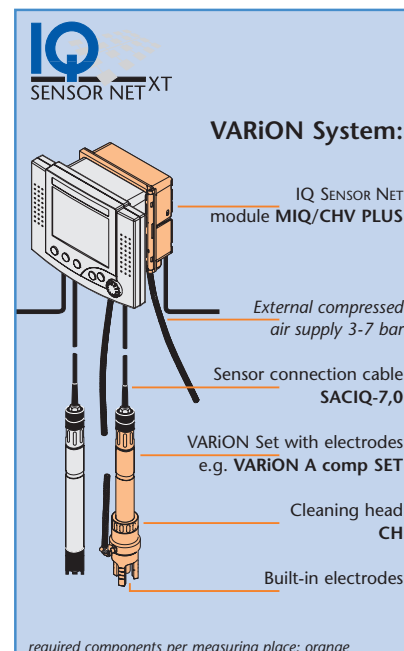

Parameter section

Dissolved Oxygen

pH/ORP

Conductivity

Turbidity/Solid Matter

Nitrogen

Phosphate

Carbon



Nitrogen AmmoLyt® System

Ammonium Measurement directly in the Medium

- in-situ ammonium sensor
- Control of the aeration process
- Automatic air cleaning



– without Sample Preparation

The continuous measuring of O₂ and NH₄ can result in significant savings through:

- energy-optimized operation due to demand-oriented regulation of aerator aggregates,
- adherence to critical values or reduction of wastewater charges.

The low investment costs for the system can thus be amortized after a short period.

Technical Data

Appropriate Electrode	Reference electrode AmmoLyt® NHA with replacement electrode AmmoLyt® NHA/AT
Measuring Ranges/Resolution	NH ₄ -N: 0.1 ... 1000 mg/l / 1 mg/l; 0.1 ... 100 mg/l / 0.1 mg/l NH ₄ ⁺ : 0.1 ... 1290 mg/l / 1 mg/l; 0.1 ... 129.0 mg/l / 0.1 mg/l mV: -2000 ... +2000 mV/1 mV
Temp. Measurement and Compensation	Integrated NTC thermistor Range: 32 ... 104 °F (0 °C ... +40 °C)
Calibration Procedures	1-point/2-point calibration with standard solution, known addition, double-known addition, in-situ calibration against reference solution
Ambient Conditions	Operating temp.: 32 ... 104 °F (0 ... +40 °C), storing temp.: 32 ... 104 °F (0 ... +40 °C)
pH Range	pH 4 ... pH 8.5
Accuracy in laboratory standard solutions	±5% of measured value ±5 mg/l
Working Life (typically)	AmmoLyt® NHA: 6 ... 12 months AmmoLyt® NHA/AT: 3 ... 8 months
Mechanical	Sensor body and temperature sensor: V4A stainless steel 1.4571 Protective cup and electrode connector: POM Protection rating: IP 68 (0.2 bar, with installed electrodes)
Max. Pressure	Maximum 0.2 bar (incl. SACIQ sensor connection cable, with installed electrodes)
Power Consumption	0.2 Watt
Dimensions	19.76 x 1.57 in. (502 x 40 mm; L X D), incl. SACIQ sensor connection cable
Weight	Approx. 2.14 lb (970 g, without electrode, without SACIQ sensor connection cable)



*on armature

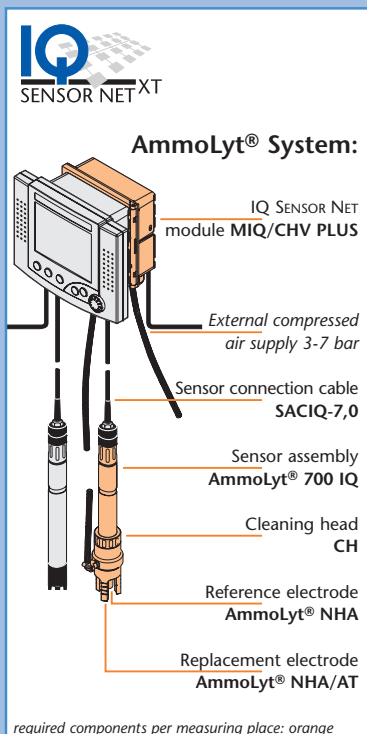

Ordering Information

AmmoLyt® System		Order No.
AmmoLyt® 700 IQ	Robust digital armature for ion-selective electrodes (AmmoLyt® NHA/AmmoLyt® NHA/AT; not included in scope of delivery)	107 002
AmmoLyt® NHA	Ammonium reference electrode	107 004
AmmoLyt® NHA/AT	Ammonium replacement electrode	107 006
CH	Cleaning head	900 107
MIQ/CHV PLUS	Valve module for automatic cleaning by compressed air controlled directly via the IQ SENSOR NET bus	480 018
DIQ/CHV	Valve module for automatic compressed air cleaning for System 182; accessible by means of an DIQ/S 182 relay	472 007
Standard Solutions see brochure "Product Details"		



TresCon[®] OA 110

Ammonium Analyzer Module



On-line ammonium measurement

- Continuous ammonium value monitoring in sewage plant effluent
- Analysis of the ammonium-nitrogen pollution in surface waters
- Monitoring water treatment plants

Measuring Principle

The continuous determination of ammonium in the OA 110 module is carried out according to the potentiometric measuring principle with a gas-sensitive NH₃ electrode. Sodium hydroxide is added to the thermostatted sample to convert the ammonium dissolved in the medium into undissociated ammonia gas. The gaseous ammonia alters the pH registered by the measuring electrode; the alteration is a direct measure of the ammonium concentration in the sample.

IP 54



2 Years Warranty

Technical Data

	Standard 1	Standard 2*
Resolution (Display)	Range: 0.10 ... 10 mg/l: 0.01 mg/l 10.0 ... 100 mg/l: 0.1 mg/l 100 ... 1280 mg/l: 1 mg/l	Range: 0.05 ... 10 mg/l: 0.01 mg/l*
Accuracy	±5% of the measured value ±0.2 mg/l at <1 mg/l NH ₄ -N ±5% of the measured value ±0.1 mg/l at 1.0 ... 100 mg/l NH ₄ -N	±5% of the measured value ±0.05 mg/l at <1 mg/l NH ₄ -N* ±5% of the measured value ±0.1 mg/l at 1.0 ... 10 mg/l NH ₄ -N*
Coefficient of variation for method	Range: 0.10 ... 10 mg/l: 3% 10.0 ... 100 mg/l: 4% 100 ... 1280 mg/l: 5%	(values for calibration with suitable standard solutions)
Response Time	< 3 min (after alteration in concentration at module input)	
Measuring interval	Continuous Mode and 10, 15, 20, 25, 30 min intervals selectable, AutoAdapt, Interval-Program	
Calibration	Automatic 2-point calibration (AutoCal) with two standard solutions	
Sample input	Approx. 0.3 l/h, solids content <50 mg/l	
Consumption	Reagent, 10 l: 14/30/50 days at measuring intervals cont./20/30 min Standard solutions A/B, 1.5 l: 60 days with 24 h calibration interval Cleaning solution, 1.5 l: 60 days with 24 h cleaning interval	
Maintenance interval	Every 6 months	*around calibration standard

Ordering Information

	Order No.
OA 110 Separate TresCon [®] analyzer module for ammonium-nitrogen for extension of an existing TresCon [®] system (requires 1 measuring place)	820 008
TresCon [®] A 111 TresCon [®] -basic instrument with analysis module OA 110 for ammonium-nitrogen (wall mounting, space for 2 further modules)	8A-10030
TCU/A111 TresCon [®] Uno ammonium: single parameter system ammonium with analysis module OA 110 for ammonium-nitrogen	820 101
Accessories and consumables see brochure "Product Details"	



TresCon[®] OA 110

- Wide measuring range of 0.1 ... 1000 mg/l NH₄-N
- Extreme long-term accuracy due to quartz-controlled pump
- Continuous measurements with automatic calibration
- Short response time
- No filtration required in effluents with low levels of suspended solids

Measuring Range 1		
	mg/l	mmol/l
NH ₄ -N	0.1 - 1000	0.01 - 71.00
NH ₄ ⁺	0.1 - 1280	0.01 - 71.00
Measuring Range 2*		
	mg/l	mmol/l
NH ₄ -N	0.05 - 10	0.005 - 0.71
NH ₄ ⁺	0.05 - 12.8	0.005 - 0.71

Parameter section

Dissolved Oxygen

pH/ORP

Conductivity

Turbidity/
Suspended Solids

Nitrogen

Phosphate

Carbon:
COD/TOC/DOC/
BOD/SAC



Nitrogen NitraLyt® System

Nitrogen Elimination Process

- in-situ nitrate sensor
- Control of the aeration process
- Automatic air cleaning

monitored · optimized · cost effective

The optimization of nitrification/denitrification during wastewater treatment is simplified even further by the new NitraLyt® system:



- Nitrate is also directly measurable during the process in addition to oxygen and ammonium.
- Measured values are promptly available and can be used directly to control the process.
- Low investment and maintenance costs (automatic compressed air cleaning system).

Technical Data

Appropriate Electrode	Reference electrode NitraLyt® NOA with replacement electrode NitraLyt® NOA/AT
Measuring Ranges/Resolution	NO ₃ -N: 0.1 ... 1000 mg/l / 1 mg/l; 0.1 ... 100 mg/l / 0.1 mg/l NO ₃ ⁻ : 0.5 ... 4500 mg/l / 5 mg/l; 0.5 ... 450.0 mg/l / 0.5 mg/l mV: -2000 ... +2000 mV/1 mV
Temp. Measurement and Compensation	Integrated NTC thermistor Range: 32 ... 104 °F (0 °C ... +40 °C)
Calibration Procedures	1-point/2-point calibration with standard solution, known addition, double-known addition, in-situ calibration against reference solution
Ambient Conditions	Operating temp.: 32 ... 104 °F (0 ... +40 °C), storing temp.: 32 ... 104 °F (0 ... +40 °C)
pH range	pH 4 ... pH 11
Accuracy in laboratory standard solutions	±5 % of measured value ±5 mg/l
Working Life (typically)	AmmoLyt® NHA: 6 ... 12 months AmmoLyt® NHA/AT: 3 ... 8 months
Mechanical	Sensor body and temperature sensor: V4A stainless steel 1.4571 Protective cup and electrode connector: POM Protection rating: IP 68 (0.2 bar, with installed electrodes)
Max. Pressure	Maximum 0.2 bar (incl. SACIQ sensor connection cable, with installed electrodes)
Power Consumption	0.2 Watt
Dimensions	19.76 x 1.57 in. (502 x 40 mm; L X D), incl. SACIQ sensor connection cable
Weight	Approx. 2.14 lb (970 g, without electrode, without SACIQ sensor connection cable)

Ordering Information

NitraLyt® System		Order No.
NitraLyt® 700 IQ	Robust digital armature for ion-selective electrodes (NitraLyt® NOA/NitraLyt® NOA/AT; not included in scope of delivery)	107 022
NitraLyt® NOA	Nitrate reference electrode	107 024
NitraLyt® NOA/AT	Nitrate replacement electrode	107 026
CH	Cleaning head	900 107
MIQ/CHV PLUS	Valve module for automatic cleaning by compressed air controlled directly via the IQ SENSOR NET bus	480 018
DIQ/CHV	Valve module for automatic compressed air cleaning for System 182; accessible by means of an DIQ/S 182 relay	472 007
Standard solutions see brochure "Product Details"		



*on armature

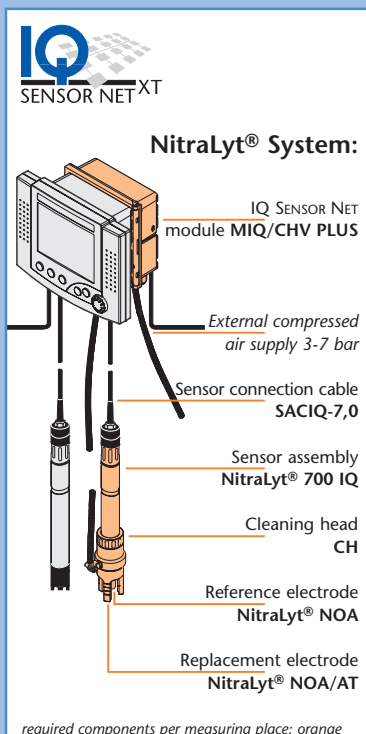



Nitrogen

NitraVis® System

in-situ Measurement of Nitrate and Suspended Solids (optional)



High-precision spectral measurement allows determination of the real nitrate value. Interfering influences caused for example by nitrite or suspended solids are easily detected due to the available spectral information and automatically taken into account or used for compensation.

The investment costs, which are slightly higher than those for the ion-selective measuring method, do not entail operation costs, amortizing the investment after a very short period.

- in-situ nitrate sensor
- Precise optical measurement
- Interference Compensation
- Automatic air cleaning
- No chemicals or consumables

Technical Data

Measuring Principle	Spectral Measurement in the UV/VIS Range (200 - 750 nm)		
Measuring Range Nitrate Standard	NO ₃ -N: municipal wastewater:	NitraVis® 700/1	NitraVis® 700/5
		0.1 ... 100 mg/l inlet, aeration	0.01 ... 25 mg/l outlet
Accuracy	±3 % of measured value ±0.5 mg/l (with Check algorithm, in standard solution)		
Measuring Range Suspended Solids (Option)	TSS: municipal wastewater:	0 ... 10.00 g/l inlet, aeration	0 ... 900.0 mg/l outlet
Materials	Housing:	Al Mg Si 1, anodized	
	Window:	Sapphire glass	
Pressure Resistance	≤1 bar		
Ambient Conditions	Operating temperature:	32 ... 113 °F (0 °C ... +45 °C)	
	Storage temperature:	14 ... 122 °F (-10 °C ... +50 °C)	
Flow velocity	≤3 m/s		
pH range	pH 4 ... pH 9		
Salt content of medium	< 5000 mg/l (Chloride)		
Dimensions	25.59 x 1.73 in. (650 x 44 mm; length x max. diameter)		
Weight	Approx. 2.43 lb (1.1 kg)		



Ordering Information

Every Sensor with 49 ft. (15 m) cable and compressed air tubing	Order No.	
NitraVis® 700/1 IQ	Optical Nitrate probe; path length 1 mm	481 021
NitraVis® 700/1 IQ TS	as NitraVis® 700/1 IQ; with integrated TSS measurement	481 022
NitraVis® 700/5 IQ	Optical Nitrate probe; path length 5 mm	481 023
NitraVis® 700/5 IQ TS	as NitraVis® 700/5 IQ; with integrated TSS measurement	481 024
MIQ/VIS	Connection module for UV/VIS sensor; directly controls the valve module for compressed air cleaning	481 029
MIQ/CHV PLUS	Valve module for automatic cleaning by compressed air controlled directly via the IQ SENSOR NET bus	480 018
DIQ/CHV	Valve module for automatic compressed air cleaning for System 182; accessible by means of an DIQ/S 182 relay	472 007

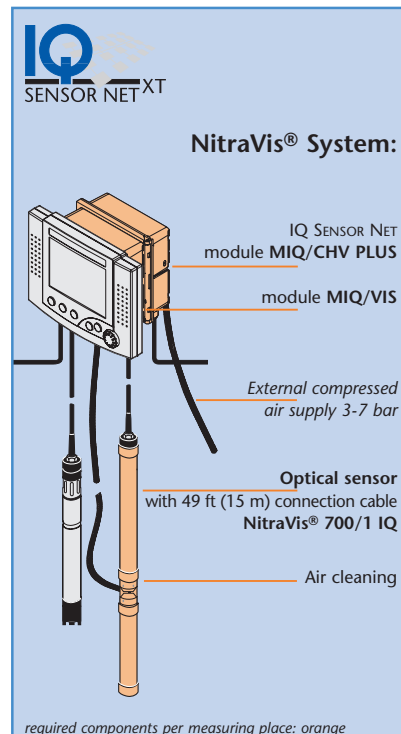



TresCon® ON 210/OS 210

Nitrate Analyzer Module Nitrate/SAC Analyzer Module

- Reagent-free measuring method
- Insensitive to interfering substances
- 4-beam measuring method for optimal background compensation
- Can be used in weakly polluted water without sample preparation
- Simultaneous nitrate and SAC determination (OS 210)

Measuring Range		
	mg/l	µmol/l
NO ₃ -N	0.1 - 60	0 - 4000
NO ₃	0.1 - 250	0 - 4000
SAC	0.1 - 200 m ⁻¹	

Nitrate/SAC measurement

- Regulating nitrate degradation in denitrification
- Continuous monitoring of nitrate effluent values
- Organic pollution SAC (OS 210)

Measuring Principle Nitrate

The ability of nitrate ions to absorb UV light of certain wavelengths is used for measuring the nitrate. The ultraviolet light from a pulsed photoflash lamp passes through a flow-thru measuring cuvette where it is partially absorbed by the nitrate ions present in the sample flow. The intensity of the attenuated light is measured at a measuring wavelength and at a reference wavelength and evaluated electronically. The 4-beam measuring method used ensures a high degree of long-term stability and absolute accuracy; interfering background influences are efficiently compensated.

SAC measuring principle

Absorption measurement of aqueous sample in UV range. The SAC (spectral absorption coefficient) represents the organic water pollution.



Technical Data

Resolution (Display)	Nitrate: Range: 0.1 ... 100 mg/l : 0.1 mg/l 100 ... 250 mg/l : 1 mg/l	
	SAC: 0.1 m ⁻¹ (only OS 210)	
Accuracy	±2% of the measured value ± 0.4 mg/l	
Coefficient of variation for method	2%	
Response Time	30 s (after alteration in concentration at module input)	
Measuring interval	Continuous mode and 5, 10, 15, 20, 25, 30 min intervals selectable, AutoAdapt, Interval-Program	
Calibration	Automatic zero balance, works calibration	
Sample Flow Rate	0.5 l/hr approx., suspended solids content <50 mg/L	
Consumption	Distilled water, 10 l: 130 days with 24 h interval for zero balance Cleaning solution, 1.5 l: 120 days with 24 h cleaning interval	
Maintenance Interval	Every 6 months	

Ordering Information

		Order No.
Separate TresCon® analyzer module for nitrate (+ SAC) for extension of an existing TresCon® system (requires 1 measuring place)		
ON210	Nitrate	820 007
OS 210	Nitrate + SAC	820 010
TresCon® basic instrument with analysis module ON 210 (nitrate) or OS 210 (nitrate + SAC) (wall mounting, space for 2 further modules)		
TresCon® N 211	Nitrate	8A-20030
TresCon® S 211	Nitrate + SAC	8A-70030
TresCon® Uno single parameter system nitrate or nitrate + SAC with analysis module ON 210 or OS 210		
TCU/N211	TresCon® Uno nitrate	820 102
TCU/S211	TresCon® Uno nitrate + SAC	820 107
Accessories and consumables see brochure "Product Details"		



TresCon[®] ON 510



Nitrite Analyzer Module



IP 54



2 Years
Warranty

On-line nitrite measurement

- Observation of the nitrification process
- Monitoring nitrite effluent values
- Measurement checks in drinking water treatment
- Monitoring nitrite pollution in natural waters
- Monitoring of critical values in fish farming

Measuring Principle

The measuring principle of the NO₂ analyzer module is based on the azo dye method. A reagent reacts with nitrite to color the sample solution pink. The intensity of the pink color is proportional to the nitrite concentration in the sample and is measured by a double-beam reference photometer. An additional manual correction facility allows the system to be adapted to plant-specific characteristics so that a high degree of measuring accuracy can be achieved even with strongly colored samples.

- Continuous background compensation
- Reliable and Accurate – 2-beam reference photometer
- Selectable measuring intervals: 10, 15 or 20 min
- Can be used in weakly polluted water without sample preparation

	Measuring Range	
	mg/l	µmol/l
NO ₂ -N	0.005 - 1.200	0.40 - 90
NO ₂	0.020 - 4.000	0.40 - 90

Technical Data

Resolution (Display)	Range: 0.005 ... 1.200 mg/l : 0.001 mg/l 0.020 ... 4.000 mg/l : 0.001 mg/l 0.40 ... 90.00 µmol/l : 0.1 µmol/l
Accuracy	±2% of the measured value ±0.05 mg/l NO ₂ -N
Coefficient of variation for method	1%
Response Time	< 5 min to measured value (after alteration in concentration at module input)
Measuring interval	5, 10, 15, and 20 min intervals selectable, AutoAdapt, Interval-Program
Calibration	Automatic 2-point calibration, time and interval selectable
Background Correction	Continuous background compensation based on new WTW algorithm
Sample input	Approx. 0.06 l/h, solid content < 50 mg/l
Consumption	Reagent, 1 l: 20/40/80 days with 5/10/20 min measuring interval Standard B, 1 l: 80 days with 24 h calibration interval Cleaning solution, 1.5 l: 45 days with 24 h cleaning interval
Maintenance Interval	Every 6 months

Ordering Information

		Order No.
ON 510	Separate TresCon [®] analyzer module for nitrite for extension of an existing TresCon [®] system (requires 1 measuring place)	820 009
TresCon [®] N 511	TresCon [®] basic instrument with analysis module ON 510 for nitrite (wall mounting, space for 2 further modules)	8A-30030
TCU/N511	TresCon [®] Uno single parameter system nitrite with analysis module ON 510	820 103
Accessories and consumables see brochure "Product Details"		

For information visit www.WTW.com for a customer care center near you or inside US: call WTW 800 645 5999.

Parameter section

Dissolved Oxygen

pH/ORP

Conductivity

Turbidity/
Suspended Solids

Nitrogen

Phosphate

Carbon:
COD/TOC/DOC/
BOD/SAC



Phosphate

Phosphorus compounds – in particular ortho-phosphate PO_4^{3-} – are considered to be the limiting nutrients in most stagnant and flowing waters. An increase in their concentration caused by higher input (wastewater, avulsion etc.) results directly in increasing eutrophication of the water with known effects such as increased growth of algae, oxygen depletion as far as anoxia in the deeper regions, etc.

Phosphorus Compounds in Water

Phosphorus occurs in 3 compounds in natural waters:

- inorganic, dissolved **ortho-phosphate**
 - dissolved organic phosphorus compounds
 - particulate phosphorus (bound in biomass or attached to particles),
- which add up to the **total of phosphorus content P_{Total}** , an important parameter in monitoring wastewater treatment plant effluents.

Measuring Methods and Digestion

There are two methods available for determining phosphate or phosphorus concentrations:

- **Molybdenum blue method**
- **Vanadate/molybdate method (yellow method)**

Both techniques are based on the measurement of **ortho-phosphate**. **Digestion** of both dissolved organic as well as particulate phosphorus compounds is therefore mandatory for determining the **total P** content. In addition, an unfiltered sample must be acquired in order to include all solid matters in the digestion process. Digestion is usually performed by heating the sample with peroxodisulfate and sulfuric acid.

Elimination of Phosphates in Wastewater

To meet the required limits of P concentration in the effluent, the modern wastewater treatment facility has two methods available:

- **Biological elimination of phosphates "Bio-P"**:
incorporation of phosphate in microbial biomass (usually in combination with a preliminary anaerobic stage to stimulate luxury consumption of phosphate and intracellular storage as polyphosphate)
- **Chemical-physical elimination of phosphates**:
Chemical precipitation of ortho-phosphates using metallic salts (usually Fe^{3+} or Al^{3+}). The use of ortho-phosphate analyzers for effective control and regulation of precipitations results in considerable savings.

Regulation according to P Concentration

With a continuous monitor PO_4 analyzer, the operator of water treatment plants can realize significant cost savings.

(cf. Application Report PO4 1609 2003 01e)

Molybdenum blue method

In an acidic medium, ortho-phosphates bond with ammonium molybdate to form molybdenic phosphoric acid. With the aid of a reducing agent this forms phosphorus molybdenum blue compound. Photometrical measurement of dye intensity can be performed at 880 nm.

Vanadate/molybdate method (yellow method)

In acids, ortho-phosphate ions react with ammonium molybdate and ammonium vanadate to form yellow ammonium phosphoric vanadomolybdate. This can be photometrically analyzed at 380 nm.



TresCon[®] OP 210

Phosphate Analyzer Module



On-line orthophosphate measurement

- Control or feedback control of chemical phosphate precipitation, e.g. precipitating agent addition with simultaneous precipitation
- Monitoring biological phosphate elimination
- Measuring the phosphate pollution in natural waters
- Monitoring the phosphate concentration in the drinking water

Measuring Principle

The PO₄ module uses the vanadate/molybdate method (yellow method) for determining the orthophosphate content. A reagent reacts with phosphate in the sample to color the sample solution yellow. The intensity of this color is recorded photometrically and evaluated as a measure of the phosphate content.

TresCon[®] OP 210

- Yellow method
- Continuous background compensation
- Continuous/Discontinuous operation selectable
- Can be used in weakly polluted water without sample preparation

Technical Data OP 210

Resolution (Display)	Measuring range 1: 0.01 mg/l or µmol/l Measuring range 2: 0.1 mg/l or µmol/l Measuring range 3: 0.1 mg/l or µmol/l
Accuracy	±2% of the measured value ±0.01 mg/l PO ₄ -P (Measuring range 1) ±2% of the measured value ±0.1 mg/l PO ₄ -P (Measuring range 2 and 3)
Coefficient of variation for method	2% (for all measuring ranges)
Response time	< 4 min to measured value (after alteration in concentration at module input)
Measuring interval	Quasi-continuous measurement; 5, 10, 15, 20, 25 or 30 min settings
Calibration	Automatic 2-point calibration (time and interval selectable)
Background correction	Continuous background compensation based on new WTW algorithm
Sample input	Approx. 0.06 l/h, solid content <50 mg/l (e.g. sewage treatment plant effluent)
Consumption	Reagent, 10 l: 60/155/310/465 days with cont. /10/20/30 min measuring intervals Standard B 1.5 l: 90 days with 24 h calibration interval Cleaning solution, 1.5 l: 45 days with 24 h cleaning interval
Maintenance interval	Every 6 months

IP54



2 Years Warranty

Measuring Range 1		
	mg/l	µmol/l
PO ₄ -P	0.05 - 3.00	1.5 - 100
PO ₄	0.15 - 9.00	1.5 - 100
Measuring Range 2		
	mg/l	µmol/l
PO ₄ -P	0.1 - 10.0	3 - 320
PO ₄	0.3 - 30.0	3 - 320
Measuring Range 3		
	mg/l	µmol/l
PO ₄ -P	0.1 - 25.0	3 - 800
PO ₄	0.3 - 80.0	3 - 800

Ordering Information OP 210

Separate TresCon [®] analyzer module for Orthophosphate for extension of an existing TresCon [®] system (requires 1 measuring place)		Order No.
OP 210/ MB 1	Module for Orthophosphate: Measuring range 1	820 004
OP 210/ MB 2	Module for Orthophosphate: Measuring range 2	820 005
OP 210/ MB 3	Module for Orthophosphate: Measuring range 3	820 006
TresCon [®] -basic instrument with analysis module OP 210 for ortho-phosphate (wall mounting, space for 2 further modules)		Order No.
TresCon [®] P 211/MB1	Orthophosphate, Measuring range 1	8A-40030
TresCon [®] P 211/MB2	Orthophosphate, Measuring range 2	8A-50030
TresCon [®] P 211/MB3	Orthophosphate, Measuring range 3	8A-60030
TresCon [®] Uno single parameter system ortho-phosphate with analysis module OP 210		Order No.
TCU/P211-MB1	TresCon [®] Uno for Orthophosphate: Measuring range 1	820 104
TCU/P211-MB2	TresCon [®] Uno for Orthophosphate: Measuring range 2	820 105
TCU/P211-MB3	TresCon [®] Uno for Orthophosphate: Measuring range 3	820 106
Accessories and Consumables see brochure "Product Details"		



TresCon®

OP 510

Total phosphorus analyzer module



- On-line analysis of total phosphorus for wastewater treatment plant effluent
- Rapid analysis at 10 min intervals
- 2-point calibration – high degree of accuracy
- Automatic Cleaning
- Automatic Monitoring
- Blue method

On-line P_{Total} measurement

- Monitoring the effluent from wastewater treatment plant for P_{Total}
- Monitoring phosphorus pollution in natural waters

Measuring Range*		
	mg/l	µmol/l
P _{Total}	0.01 ... 3.00/ 6.00*	0.3 ... 100/ 200*

* by continuous sample dilution in a 1:1 ratio

IP 54



2 Years Warranty



Measuring Principle

The P_{Total} module consists of two units: in the first unit (digestion unit) the sample undergoes a chemical-thermal digestion; in the second unit the total phosphorus content is determined.

During the **digestion** all the phosphorus compounds contained in the sample are converted to orthophosphate; this can be determined photometrically. The phosphorus compounds are oxidized by peroxodisulfate under acidic conditions. This process is accelerated by overpressure and an increased temperature so that very short digestion times are achieved.

The subsequent **analysis** is by the molybdenum blue method. The sample is mixed with a molybdate reagent which reacts with phosphate via an intermediate chemical step to form a blue coloration. The intensity of this coloration is a measure of the original concentration of the phosphate ions. It is measured photometrically and evaluated.

Technical Data

Resolution (Display)	Range: 0.01 ... 3.00 mg/l : 0.01 mg/l 0.30 ... 100 µmol/l : 0.1 µmol/l
Accuracy	±3% of the measured value ±0.05 mg/l P _{Total}
Measuring principle	Photometric reference beam method after digestion
Measuring method	Molybdenum blue method
Coefficient of variation for method	1.5%
Measuring interval	10, 15, 20, 25, 30 or 60 min can be set (DIN EN measurement with 30 min digestion at approx. 248 °F/120 °C)
Calibration	Fully automatic 2-point calibration
Consumption	Reagents A, B, C, D: 10/15/20/30/60 days with 10/15/20/30/60 min measuring interval Standard, 1.5 l: 70 days with 24 h calibration interval Cleaning solution, 1.5 l: 60 days with 24 h cleaning interval
Maintenance interval	Every 6 months

Ordering Information Total Phosphorus OP 510

		Order No.
OP 510	Separate TresCon® analyzer module for total phosphorus for extension of an existing TresCon® system (requires 2 TresCon® measuring places)	820 011
TresCon® P 511	TresCon®-basic instrument with analysis module OP 510 for total phosphorus (wall mounting, space for 1 further module) Accessories and Consumables see brochure "Product Details"	8A-8X030

Homogenizer available on demand (see brochure "Product Details")



Carbon

Carbon

Carbon parameters:

TOC:

A measure for the total organically bound carbon

DOC:

Dissolved organic share of TOC

COD:

Contains all substances that can be solubilized by chemical oxidation. It is at the same time the conventional parameter for the calculation of wastewater charges

BOD:

Contains only the compounds that can be oxidated microbiologically

The main task of a waste water treatment plant is to reduce the total organic load of waste water in addition to all the progress made in nitrogen and phosphate elimination. Organic compounds consist mainly of the elements carbon and hydrogen. The cleaning process converts them to carbon dioxide and water while consuming oxygen.

Carbon parameters

To measure the organic load of water, the parameters TOC, DOC, COD or BOD are used. The differences of these parameters (marginal column) show that these measurements are not identical and that the measured values therefore can not be equal.

Analysis procedures

For an analytical online determination, all these parameters require complex procedures for digestion and the corresponding instrumentation.

COD measurement in the laboratory



Individual measurement
=> time-delayed,
suitable for monitoring

In-situ measurement using a spectrometer sensor



Continuous measurement
=> fast response time,
suitable for control strategies

SAC

The SAC (spectral absorption coefficient) is a parameter that can be determined more easily. Many organic compounds have characteristic UV absorption spectrums. The intensity of the light attenuation can, therefore, be correlated with the organic load.

This correlation is significant in measuring media with low variations of composition concerning color, solids and their optical characteristics. Waste water, however, contains many substances with completely different optical characteristics. For each substance, a different correlation factor concerning the carbon content applies.



Measuring at only one wavelength, e.g. at 254 nm for the SAC₂₅₄, can often show the load only inadequately – especially if the matrix changes.

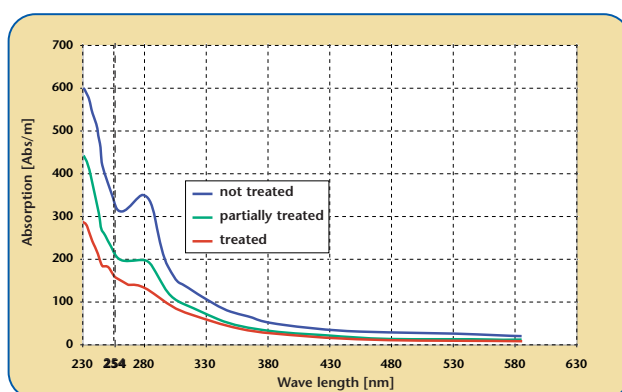

Spectrum of waste water samples of a waste water treatment plant:

The measured absorption spectrum of this waste water treatment plant shows a characteristic maximum at approx. 280 nm that is caused by dissolved, biodegradable substances (they are degraded during the cleaning process; the absorption peak disappears nearly completely).

Measuring the SAC at 254 nm cannot include these compounds, as the absorption is nearly exclusively caused by solids in this range and there is no correlation with the dissolved, degradable ingredients at this wavelength.

New on-line spectrometer probes

The **CarboVis®** and **NiCaVis®** sensors measure the total spectrum range from ultra-violet to long wave visible light.

The measured values are determined from the high information content of the spectral data. The calculation is based on methods and characteristics that were achieved from a multitude of measurements and longtime analyses. The user can, therefore, select algorithms that are adapted to the measuring site (inlet, outlet etc.) having a high correlation with the basic parameter COD.

The spectral procedure has an additional advantage: the turbidity of the test sample, which affects optical measurements, is optimally compensated over a wide wavelength range.

The determined measurement result is displayed directly as **mg/l COD**. A known correlation between this basic parameter COD and one of the related carbon parameters (TOC, DOC or BOD, to be selected) can be set by means of a user-specific calibration. The result is then displayed directly as, e.g. mg/l TOC.

Applications

The most important measuring points of waste water treatment plants are the inlet and outlet.

To determine the incoming load of the plant, a **CarboVis®** sensor is positioned in the inlet. The load found in the outlet of the plant is low. With a "CarboVis®" installed there (possibly with integrated total suspended solids measurement), the cleaning performance of this plant can be monitored well. The **NiCaVis®** combination sensor is also suitable for the outlet. It measures the carbon content as well as the nitrate concentration.



CarboVis[®]-/NiCaVis[®]- System

in-situ measurement of Nitrate, COD, TOC, DOC, BOD or SAC

- in-situ measurement – fast response
- Automatic air cleaning
- No consumables
- No ecologically harmful chemicals

IP 68



1 Year
Warranty

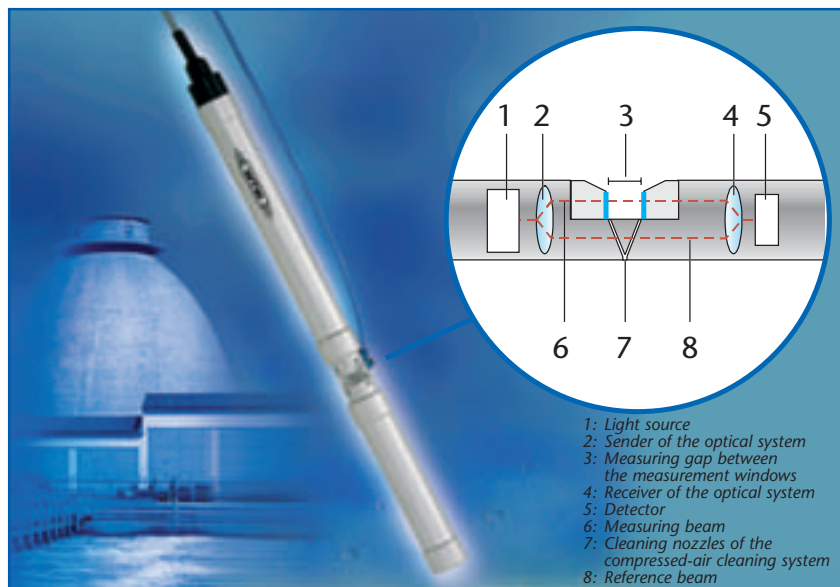

High quality spectral measurement in a waterproof version for direct process control

Highly precise spectral measurement in a 1.57 in. (40 mm) in diameter sensor. Determination of measured values by spectral processing of the scanned UV/VIS spectrum. The TSS result is generally used for internal compensation. As an option the TSS value can be displayed as second parameter.

Features in detail:

- The sensor measures directly in the process medium. No sample transport, no sample preparation necessary.
- No lag-time between sampling and result of the measurement. Current values immediately available.
- Extremely precise measurement due to the spectral analysis of the scanned UV/VIS range.
- Very effective compensation of interferences and turbidity based on the spectral information – much better than a simple dual-beam measurement!
- Long operation periods by automatic air cleaning – almost maintenance-free.
- Optical system works without consumables
-> low costs of ownership.



Carbon

Parameter section

Dissolved Oxygen

pH/ORP

Conductivity

Turbidity/
Suspended Solids

Nitrogen

Phosphate

Carbon:
COD/TOC/DOC/
BOD/SAC

Technical Data

Measuring Principle	Spectral measurement in the UV/VIS range (200 - 750 nm)	
	CarboVis® 700/5 IQ	NiCaVis® 700/5 IQ
Applications	Municipal waste water: inlet, effluent	Municipal waste water: effluent
Measuring Ranges in Standard Solution (potassium-hydrogenphthalate)	COD: 0.1 ... 800.0 mg/l TOC: 1 ... 500.0 mg/l SAC: 0.1 ... 600.0 1/m	COD: 0.1 ... 800.0 mg/l TOC: 1 ... 500.0 mg/l SAC: 0,1 ... 600.0 1/m NO ₃ -N:0.01 ... 25.00 mg/l
Accuracy in Standard Solution	±3 % of measured value ±2.5 mg/l (with Check algorithm)	
Measuring Ranges TSS (Option)	Inlet: 0 ... 3000 mg/l TS Effluent: 0.0 ... 900.0 mg/l TS	—
Materials	Housing: Al Mg Si 1, anodized Windows: sapphire glass	
Pressure Resistance	≤1 bar	
Ambient Conditions	Operating temperature: 32 ... 113 °F (0 °C ... +45 °C) Storage temperature: 14 ... 122 °F (-10 °C ... +50 °C)	
Flow velocity	≤3 m/s	
pH range	pH 4 ... pH 9	
Salt content of medium	< 5000 mg/l (Chloride)	
Dimensions	25.59 x 1.73 in. (650 x 44 mm; length x max. diameter)	
Weight	Approx. 2.4 pounds (1.1 kg)	

Ordering Information

All sensors with 49 ft. (15 m) cable and compressed air tubing		Order No.
CarboVis® 700/5 IQ	Optical COD/TOC/DOC/BOD/SAC probe with spectral processing of the UV/VIS range; path length 5 mm.	481 025
CarboVis® 700/5 IQ TS	same as model CarboVis® 700/5 IQ, additionally with TSS measurement.	481 026
NiCaVis® 700/5 IQ	Optical probe for measuring Nitrate and COD/TOC/DOC/BOD/SAC with spectral processing of the UV/VIS range; path length 5 mm.	481 027
MIQ/VIS	Connection module for UV/VIS sensor; directly controls the valve module for compressed air cleaning	481 029
MIQ/CHV PLUS	Cleaning head valve for automatic air cleaning; directly controllable via the IQ SENSOR NET bus	480 018
DIQ/CHV	Valve module for automatic compressed air cleaning for system 182; accessible by means of an DIQ/S 182 relay	472 007

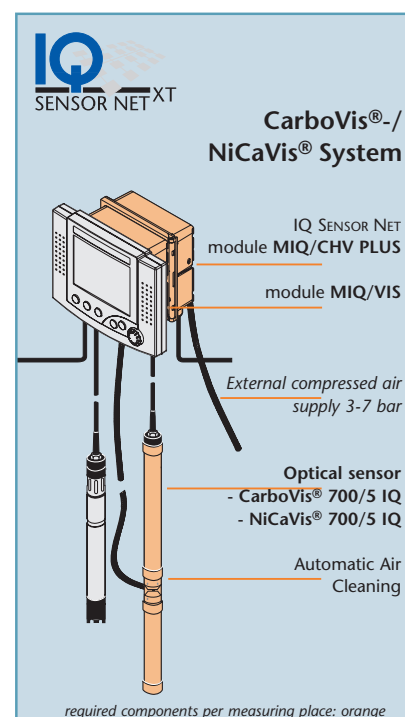



Oxi 170, pH 170, LF 170

QuadroLine®

Oxi 296, pH 296, LF 296



- Built-in lightning protection
- No EMC Interference
- Galvanically isolated inputs and outputs
- IP 66 housing or 3.78 x 3.78 in. (96 x 96 mm) panel mounting



EcoLine 170



QuadroLine® 296



Outstanding price/performance ratio

State-of-the-art technology, easy of use and maximum operating safety at an attractive price were the basic design criteria for the development of the EcoLine monitors. As a result of the logical further development of the successful EMC concept, WTW has also been able to make these advantages available to customers at an attractive price.

With the EcoLine series WTW offers an economical and technically flexible and reliable system solution which is suitable for a wide range of applications water and wastewater applications.

The QuadroLine® series is an extremely powerful monitor in a compact form and at an attractive price-performance ratio. These monitors are intended to be built into control panels and fulfill all the requirements which industrial practice demands from such systems today. Based on the proven technology of the WTW monitors of the EcoLine family, the QuadroLine® instruments have the same impressive performance features such as built-in lightning/overvoltage protection, galvanic separation of the inputs and outputs and increased EMC stability. EcoLine and QuadroLine® monitors are the right choice when single point measurements require a dedicated monitor.



EcoLine/QuadroLine®

General Description of Meters
Monitors
IQ SENSOR NET
Analyzer
Sample Preparation
Samplers
Accessories
Measuring stations

Technical Data EcoLine Oxi 170/QuadroLine® Oxi 296

		D.O. Measurement
Measuring Ranges		0.0 ... 60.0 mg/l or 0 ... 600 % saturation, user-selectable
Resolution		0.1 mg/l or 0.01 mg/l; 1 % or 0.1 % (depending upon the sensor)
Accuracy		±1 % of value, ±1 digit
Signal Input		Low-impedance, isolated from output
Temperature Measurement		NTC resistor (integrated in the sensor), 23 °F ... 122 °F (-5 °C ... +50 °C); 0,1 K resolution
Temperature Compensation		Range: 23 °F ... 122 °F (-5 °C ... +50 °C)
Atmospheric Pressure Correction		Range: 500 ... 1100 mbar; manual parameter input
Salinity Correction		2.0 ... 70.0
Relay Outputs		1 Sensor alarm relay (SensReg/SensLeck function) 2 programmable relays (setpoints, delay, hysteresis), ①+② Relays are form C rated 5A at 230 VAC, max. 5A @ 30 VDC resistive
Analog Outputs		0/4 - 20 mA outputs for D.O. and in version ①+② additionally for temperature, max. load 600 Ω; output span and recorder damping adjustable by software
Digital Interface		RS 485 interface; bus operation possible with up to 31 units ②
Ambient Conditions		Operating temperature: -13 °F ... 131 °F (-25 °C ... +55 °C); Storage temperature: -13 °F ... 149 °F (-25 °C ... +65 °C); Klima class 4 (VDI/VDE 3540)
Electrical Connections	Oxi 170	Sensor input: quick disconnect 7-pole receptacle Outputs, mains supply: via plug-in terminal strips
	Oxi 296	Sensor input, signal inputs and outputs, mains supply: via plug-in terminal strips; accessible from rear
Input Power		115/230 VAC (-15/+10 %), 48 ... 62 Hz (18 VA max.), 24 VAC (-15/+10 %), 24 VDC (-30/+20 %)
Integrated Lightning Protection		Coarse and fine protection, surpasses EN 61326 requirements
EMI/RFI Conformance		EN 61326 Class B, FCC Class A
Certifications		CE, CUL, UL (pending)
Housing	Oxi 170	Watertight housing (PC/GF20) with threaded receptacle and four cable feed-through connections (PG compression fittings, 10-14 mm dia.); Protection rating IP66 (exceeds NEMA 4X).
	Oxi 296	Fiberglass-reinforced Noryl housing with membrane keypad (Polyester); Protection rating IP 54 (front panel)
Dimensions (W x H x D)	Oxi 170	8.74 x 7.95 x 4.13 in. (222 x 202 x 105 mm)
	Oxi 296	3.78 x 3.78 x 7.32 in. (96 x 96 x 186 mm)
Weight	Oxi 170	Approx. 7.7 lb (3.5 kg)
	Oxi 296	Approx. 2.2 lb (1 kg)
		① R-T-version ② R-T-RS-version

Ordering Information EcoLine Oxi 170/QuadroLine® Oxi 296

EcoLine Oxi 170		Order No.
Oxi 170, 230 VAC	D.O. field monitor, 230 VAC 50/60 Hz; standard model	281 112
Oxi 170 RT, 230 VAC	Same as standard model, with 2 programmable relays and second analog output for temperature	282 212
Oxi 170 RT RS, 230 VAC	Same as standard model, with 2 programmable relays and second analog output for temperature and RS 485 interface	282 222
QuadroLine® Oxi 296		Order No.
Oxi 296, 230 VAC	D.O. panel mount monitor, 230 VAC 50/60 Hz; standard model	291 112
Oxi 296 RT, 230 VAC	Same as standard model, with 2 programmable relays and second analog output for temperature	292 212
Oxi 296 RT RS, 230 VAC	Same as standard model, with 2 programmable relays and second analog output for temperature and RS 485 interface	292 222
Other power supplies see brochure "Product Details"		



Technical Data EcoLine pH 170/QuadroLine® pH 296

	pH Measurement	ORP Measurement	Temperature Measurement
Measuring Range	0.00 ... 14.00 pH	-1000 mV ... +1000 mV	NTC: 23 ... 212 °F (-5 ... 100 °C) Pt 100/Pt 1000: -4...266 °F (-20...130 °C)
Resolution	0.01 pH	1 mV	0.1 K
Accuracy (± 1 Digit)	±0.01 pH	± 2 mV	NTC: ±0.2 K; Pt 100/Pt 1000: ±0.1 K fine adjustment ± 0.5 K
Signal Input	Low impedance or high impedance	Low impedance or high impedance	2-conductor (NTC); 3-conductor (Pt 100/Pt 1000)
Temperature Measurement	NTC thermistor, integrated in SensoLyte® sensor assembly; or separate NTC/Pt 100/ Pt 1000		
Temperature Compensation	NTC: 23 °F ... 212 °F (-5 °C ... 100 °C); Pt 100/Pt 1000: -4 °F ... 266 °F (-20 °C ... 130 °C)		
Calibration	AutoCal1: Automatic calibration with technical buffer solutions AutoCal2: Automatic calibration with technical buffer solutions and subsequent analog output of buffers used in calibration ConCal®: Manual calibration with any buffer solutions		
Calibration Range	Slope range: -62 mV/pH ≤ S ≤ -50 mV/pH Asymmetry potential: -45 mV ≤ U _{asy} ≤ +45 m		
Display	Dual numeric LCD-readout, 3 1/2 digits for values and display of units; Graphic symbols for auxiliary information and operator guidance		
Relay Outputs	1 Sensor alarm relay (sensor failure); 2 programmable relays (setpoints, delay, hysteresis, control function), ①+② ; Relays are form C rated 5A at 230 VAC, max. 5A @ 30 VDC resistive		
Analog Outputs	0/4 - 20 mA outputs for pH/ORP and in version ①+② additionally for temperature; max. load 600 Ω; output span and recorder damping adjustable by software		
Serial Interface	RS 485 interface, bus operation with up to 31 instruments possible ②		
Ambient Conditions	Operating temperature: -13...131 °F (-25...+55 °C); Storage temperature: -13...149 °F (-25 ...+65 °C); Clima class 4 (VDI/VDE 3540)		
Electrical Connections	pH 170	Sensor input: quick disconnect 7-pole receptacle; Signal inputs and outputs, mains supply: via plug-in terminal strips	
	pH 296	Sensor input, signal inputs and outputs, mains supply: via plug-in terminal strips; accessible from rear	
Input Power	115/230 VAC (-15/+10 %), 48-62 Hz (18 VA max.); 24 VAC (-15/+10 %), 24 VDC (-30/+20 %)		
Integrated Lightning Protection	Coarse and fine protection, surpasses EN 61326 requirements		
EMI/RFI Conformance	EN 61 326 Class B, FCC class A		
Certifications	CE, CUL, UL (pending)		
Housing	pH 170	Watertight housing (PC/GF20) with threaded receptacle and four cable feed-through connections (PG compression fittings, 10-14 mm dia.); Protection rating: IP66 (exceeds NEMA 4X).	
	pH 296	Fiberglass-reinforced Noryl housing with membrane keypad (Polyester); Protection rating: IP54 (front panel)	
Dimensions	pH 170	8.74 x 7.95 x 4.13 in. (222 x 202 x 105 mm)	
(W x H x D)	pH 296	3.78 x 3.78 x 7.32 in. (96 x 96 x 186 mm)	
Weight	pH 170	Approx. 7.7 lb (3.5 kg)	
	pH 296	Approx. 2.2 lb (1 kg)	

① R-T-version

② R-T-RS-version

Ordering Information EcoLine pH 170/QuadroLine® pH 296

EcoLine pH 170		Order No.
pH 170, 230 VAC	pH/ORP field monitor, 230 VAC 50/60 Hz; standard model	181 112
pH 170 RT, 230 VAC	Same as standard model, with 2 programmable relays and second analog output for temperature	182 212
pH 170 RT RS, 230 VAC	Same as standard model, with 2 programmable relays and second analog output for temperature and RS 485 interface	182 222
QuadroLine® pH 296		Order No.
pH 296, 230 VAC	pH/ORP panel mount monitor, 230 VAC 50/60 Hz; standard model	191 112
pH 296 RT, 230 VAC	Same as standard model, with 2 programmable relays and second analog output for temperature	192 212
pH 296 RT RS, 230 VAC	Same as standard model, with 2 programmable relays and second analog output for temperature and RS 485 interface	192 222
Other power supplies see brochure "Product Details"		

IQ SENSOR NET

SENSOR NET

The modular multi-parameter measuring system

- Universal online measuring system
- For any parameter
- Upgradable analog and digital connections



NEW

System 182 XT

with 4 analog outputs and 5 relays

Digital and universal, for

- user choice of any two sensors
- additional analog outputs, e.g. for temperature

The IQ SENSOR NET is a modular system for precise online measurements:

- pH, ORP, oxygen, temperature, turbidity/TSS, ammonium, nitrate, COD and more
- Single parameter units and multiparameter systems
- Analog outputs and relays, digital interfaces (PROFIBUS DP(V1 with FDT/DTM), Modbus RTU)

With special security features for fail-safe operation, such as:

- Integrated lightning protection (coarse and fine protection)
- Programmable status in case of error
- Automatic power fail restart
- Optional redundant controller for 100% availability
- Software for storing, saving, documenting and reloading system configuration

Simple installation using:

- 2-wire-connection technology
- Plug & play connection of any IQ sensor
- Simple system expansion by easily adding modules or sensors
- Install components where needed (e.g. analog outputs close to PLC or directly in control room)





IQ SENSOR NET

The IQ sensors with digital interface enable:

- large distances in-between sensors and between sensors and measuring system
- signal transmission which is immune to interference
- calibration data are stored in the sensor, calibration can be performed in the laboratory

Stackable modules and digital communication of the IQ system allows:

- analog and digital world combinations
- well laid-out graphic display of measured values
- digital transmission, storage and analysis of measured values

Systems 182, 184 XT and 2020 XT



U.S. patent granted
(US 6,655,233 B2)

Choose the system that's right for your application:

	System 182		System 184 XT		System 2020 XT	
Max. number of sensors	2		12		20	
Output signals	ANALOG:	DIGITAL:	ANALOG:	DIGITAL:	ANALOG:	DIGITAL:
	Analog outputs, (0/4 - 20 mA), Relays	<ul style="list-style-type: none"> • RS 485 • PROFIBUS DP • Modbus RTU 	Analog outputs, (0/4 - 20 mA), Relays	<ul style="list-style-type: none"> • via RS 232 – PC software terminal and data server function 	Analog outputs, (0/4 - 20 mA), Relays	<ul style="list-style-type: none"> • via RS 232 – PC software terminal and data server function • RS 232-modem • RS 485 • PROFIBUS DPV1 with FDT/DTM • Modbus RTU
					(digital standards parallel to analog possible)	
Knowledge of special automation technology required	Basically no, in PROFIBUS/Modbus systems yes		No		Basically no, in PROFIBUS/Modbus systems yes	
Additional Options						
Additional Displays	No		Yes		Yes	
Redundant controller	No		Yes		Yes	
Datalogger	No		Yes		Yes, enhanced performance	
Modem-capable interface (fixed line telephone and mobile network)	No		No		NEW Yes Alarms and measured values via SMS	
Radio transmission	Yes		Yes		Yes	

NEW

* The double sensors VARION 700 IQ, NitraVis® 700/x IQ TS, CarboVis® 700/5 IQ TS and NiCaVis® 700/5 IQ need 2 sensor spaces.

System 182 for up to 2 sensors

It is particularly suitable as a replacement or supplement for single parameter systems in existing water and wastewater treatment plants. It can be easily integrated in existing process control systems using PROFIBUS or Modbus options but also the conventional analog version with analog outputs and relays.

NEW System 182 XT

In addition to the basic version with 2 analog outputs and 3 relays an XT version with a total of 4 analog outputs and 5 relays is available.

System 184 XT for up to 12 sensors

particularly suitable for conventional facilities, in which the user wishes to combine the advantages of digital sensor technology with the simplicity of conventional instrumentation. Signal relaying is generally performed by means of 0/4-20 mA analog outputs and relays.

System 2020 XT for up to 20 sensors

is the system of choice for a large number sensors, for digital interfaces and as futureproof instrumentation, if for example a PROFIBUS control is planned in an upcoming extension phase.

System 182

DIQ/S 182

NEW

DIQ/S 182 XT



4 x mA;
5 x relays

2 x IQ sensors can be
connected directly



This universal monitor for 1 or 2 digital sensors is particularly suitable as a replacement or supplement for single parameter systems in existing water and wastewater treatment plants:

- Two user-defined sensors may be connected; a total of **19 different sensors are available**
- All parameters, from **pH, ORP, DO, temperature and turbidity/suspended solids** and the nutrient parameters **ammonium, nitrate and COD may be measured directly in the process**
- Integrated power supply unit (110-240 VAC) or a 24 V power supply unit
- Digital **PROFIBUS** or **Modbus** outputs
- Analog version with **2 analog outputs and 3 relays**
alternative **XT version with 4 analog outputs and 5 relays**

Typical applications, e.g. **control** of nitrification/denitrification can be covered with one single system 182: Just connect the DO and the ammonium or nitrate sensor and you will instantly obtain the data to control your process!

IP 66



cETLus

3 Years
Warranty



System 182 Components

System 182 is a remarkably compact two-channel monitor with integrated power supply, controller, operating unit, analog outputs and relays or optional digital outputs available.

Display of measured values and operator guidance

The user can select the display of either a single or of two measurement values including a secondary parameter (e.g. temperature). For a quick survey, the status of all relays and outputs can be simultaneously displayed in one overview. Clear text operator guidance is identical with all IQ SENSOR NET Systems.

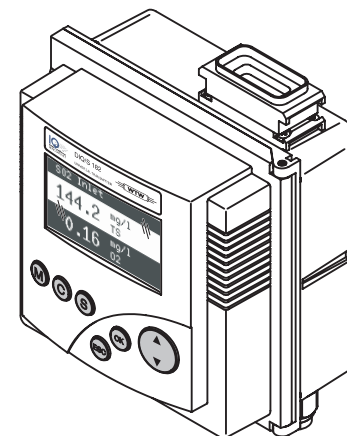

DIQ/S 182

Sensor connection and system configuration

Upon connection, any IQ sensor will be automatically recognized by the system and the measured value will be displayed instantly. If needed, an additional power supply unit may be adapted. This is necessary for sensors with high power consumption, e.g. the NitraVis®, CarboVis®, NiCaVis® 700 IQ UV-VIS sensors or for operation of two turbidity sensors with ultrasound cleaning system at one monitor. The different modules can be stack mounted, thereby simultaneously establishing the electrical connection between the modules. Any cable lengths up to 850 ft. (250 m) may be used within one system.

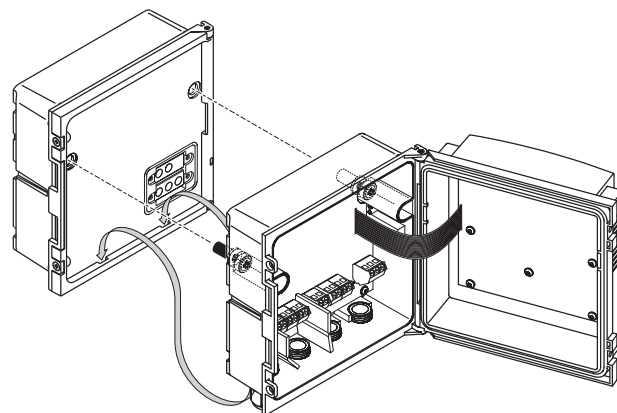

Stack mounting DIQ/S 182 with additional power supply unit

Branching module for sensors and magnetic valve module for automatic air cleaning

A plain "junction box" DIQ/JB is available for connecting a second or a remote IQ sensor.

The solenoid valve required for automatic air cleaning is located in the DIQ/CHV module of the same line. It can be used for the ion selective sensors for ammonium and nitrate and for the UV-VIS sensors as well. It is controlled directly by a relay of the monitor.

These two modules can be mounted on a common fitting panel and attached to a mounting stand.



DIQ module



Configuration Options

Configuration Options for System 182

Example 1

Configuration Example	Order No.
DIQ/S 182	472 000
SACIQ-7,0	480 042
IQ Sensor	user selected

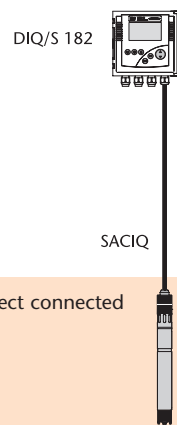

Transmitter with 1 direct connected IQ sensor

Example 2

Configuration Example	Order No.
DIQ/S 182	472 000
DIQ/JB	472 005
2 x SACIQ-7,0	480 042
2 IQ Sensors	user selected

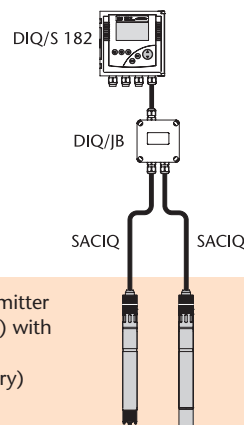

2 channel transmitter (analog outputs) with 2 IQ sensors (DIQ/JB necessary)

Example 3

Configuration Example	Order No.
DIQ/S 182 XT	472 001
2 x SACIQ-7,0	480 042
2 IQ Sensors	user selected

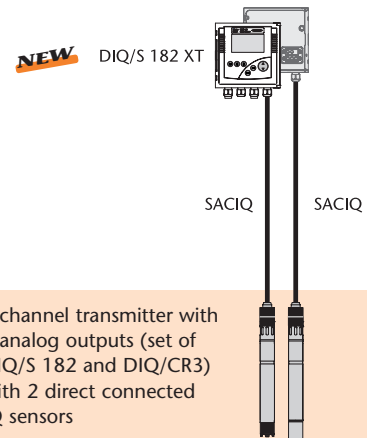

2 channel transmitter with 4 analog outputs (set of DIQ/S 182 and DIQ/CR3) with 2 direct connected IQ sensors

Example 4

Configuration Example	Order No.
DIQ/S 182-PR	472 002
2 x SACIQ-7,0	480 042
2 IQ Sensors	user selected

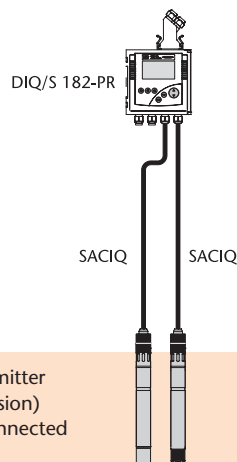

2 channel transmitter (PR or MOD version) with 2 direct connected IQ sensors

Example 5

Configuration Example	Order No.
DIQ/S 182	472 000
DIQ/JB	472 005
DIQ/CHV	472 007
CH	900 107
2 x SACIQ-7,0	480 042
2 IQ Sensors	user selected

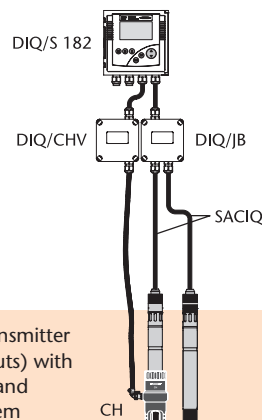

2 channel transmitter (analog outputs) with 2 IQ sensors and cleaning system

Example 6

Configuration Example	Order No.
DIQ/S 182	472 000
MIQ/VIS	481 029
MIQ/PS	480 004
DIQ/CHV	472 007
NitraVis® 700/1 IQ	481 021
SACIQ-7,0	480 042
IQ Sensor	user selected

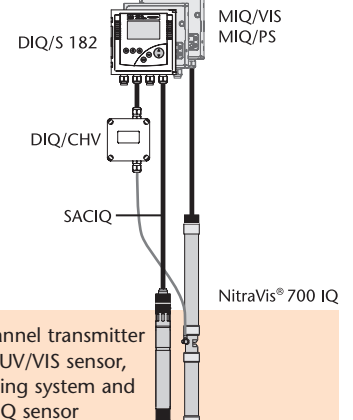

2 channel transmitter with UV/VIS sensor, cleaning system and 2nd IQ sensor

Ordering Information System 182

Monitors		Order No.
DIQ/S 182	Dual IQ/system 182, Universal Transmitter for connection of 2 digital IQ sensors, with 2 analog outputs (0/4-20 mA) and 3 relays	472 000
DIQ/S 182 XT	Dual IQ/ system 182, Universal Transmitter for connection of 2 digital IQ sensors, with 4 analog outputs (0/4-20 mA) and 5 relays	472 001
DIQ/S 182-PR	Dual IQ/system 182, UUniversal Transmitter for connection of 2 digital IQ sensors, with 3 relays and PROFIBUS-DP connection	472 002
DIQ/S 182-MOD	Dual IQ/system 182, Universal Transmitter for connection of 2 digital IQ sensors, with 3 relays and MODBUS RTU/RS 485 connection	472 003
DIQ/S 182/24V	Dual IQ/system 182, Universal Transmitter for connection of 2 digital IQ sensors, with 2 analog outputs (0/4-20 mA) and 3 relays, for 24 V AC/DC power supply	472 010
DIQ/S 182 XT/24V	Dual IQ/ system 182, Universal Transmitter for connection of 2 digital IQ sensors, with 4 analog outputs (0/4-20 mA) and 5 relays, for 24 V AC/DC power supply	472 011
DIQ/S 182-PR/24V	Dual IQ/system 182, Universal Transmitter for connection of 2 digital IQ sensors, with 3 relays and PROFIBUS-DP connection, for 24 V AC/DC power supply	472 012
DIQ/S 182-MOD/24V	Dual IQ/system 182, Universal Transmitter for connection of 2 digital IQ sensors, with 3 relays and MODBUS RTU/RS 485 connection, for 24 V AC/DC power supply	472 013
DIQ Modules		
DIQ/JB	Dual IQ/Junction box for connection of a second or a further IQ sensor to the Universal Transmitter DIQ/S 182 (system 182)	472 005
DIQ/CHV	Dual IQ/Cleaning Head Valve for automatic air cleaning controlled by a relay for system 182 (relay and compressed air supply external)	472 007
MS/DIQ	Mounting plate for up to 2 DIQ modules (DIQ/CHV and DIQ/JB)	472 009
MIQ Module and Cables for System Supplement		
MIQ/Blue PS NEW	Module IQ/Radio transmission, for wireless connection within the IQ SENSOR NET system, for system 182, 184 XT and 2020 XT. SET with two pairwise preconfigured modules	480 021
MIQ/VIS	Module IQ/VIS for connecting one UV/VIS probe NitraVis®/CarboVis®/NiCaVis® 700 IQ to the IQ SENSOR NET, fo system 2020 XT, 184 XT and 182	481 029
MIQ/PS	Module IQ/Power Supply, wide-range power supply for system 182, 2020 XT and 184 XT, power output max. 18 W	480 004
MIQ/24V	Module IQ/24V, power supply for 24 VAC / 24 VDC input voltage, for system 182, 2020 XT and 184 XT, power output max. 18 W	480 006
SNCIQ	Specific two-wire IQ SENSOR NET cable with shield for safe power/information transfer within the IQ SENSOR NET system. Please indicate cable length in m when ordering (unit: m)	480 046
SNCIQ/UG	Specific two-wire IQ SENSOR NET cable with shield for safe power/information transfer within the IQ SENSOR NET system, esp. for use in underground. Please indicate cable length in m when ordering (unit: m)	480 047
Mounting Material for Monitors		
SSH/IQ	Sun shield for mounting of IQ SENSOR NET modules and series 171/170 monitors to mounting stands	109 295
PMS/IQ	Kit for panel mounting of IQ SENSOR NET modules	480 048
THS/IQ	Kit for top hat rail mounting of IQ SENSOR NET modules	480 050
WMS/IQ	Kit for wall mounting of IQ SENSOR NET modules	480 052
SD/K 170	Sun shield for outdoor installation of junction boxes (e.g. junction boxes Kl/pH 170) or an IQ SENSOR NET module	109 284
MR/SD 170	Mounting kit for attaching of sun shields to pipes	109 286



Systems 184 XT and 2020 XT – the modular solution for today and for the future



IP 66



GETLUS

3 Years
Warranty

Do you plan to use more than two sensors or to upgrade your installation step by step?

If so, the systems 184 XT and 2020 XT are the solution to your needs: These fully modular systems will “keep on growing” at the pace of your growing demand! Their flexibility makes them particularly appealing for smaller to medium and for larger sewage treatment plants as well. From discharge measuring with parameters turbidity, pH, conductivity and temperature to nitrification/denitrification control, all conceivable applications can be performed, as well as the complete sewage treatment plant water analysis by means of one single system. These benefits are achieved at very low investment costs, and due to the easy handling of the system the operation is highly cost-effective, too.

- Up to **12/20** digital IQ sensors at user’s choice may be connected
- Easy **system expansion**, no previous knowledge required
- Centralized power supply using a wide range power supply (100-240 VAC) or 24 V variant
- A nearly unlimited number of relays and analog outputs (0/4-20 mA) may be selected
- Digital outputs **PROFIBUS DPV1** or **Modbus RTU**
- Optional modem connection via **analog** or **GSM modem**
- **Wireless connection** via radio transmission
- **Easy integration** of existing measuring points by mA inputs

Signal processing

Generally, the signal processing with System 184 XT is analog via 0/4-20 mA outputs or relays. Should a digital connection via standardized field bus interfaces to a superordinate control system be required (either in present or in a future planning stage), System 2020 XT is the first choice, as it is optionally available with PROFIBUS DPV1 or Modbus interface besides the analog output.

In the PROFIBUS configuration System 2020 XT is operated as subsystem (1 participant), thereby gaining considerable advantages over PROFIBUS-only systems:

- Direct connection to PLC via PROFIBUS DP, but with the ease of use of Profibus PA (2-wire technology, any bus topology, configuration and parameterization per FDT/DTM) and including power supply for sensors with high power demand and cleaning devices
- No specialized personnel required for replacement of sensors or other components
- Sensor calibration in the laboratory and on-site connection of pre-calibrated sensor possible
- For particularly critical applications, parallel installation of analog outputs and relays in addition to digital signal transmission is possible, in order to implement prescribed safety strategies in the case of control system failure.

System 184 XT



MIQ/C184 XT

System 2020 XT



MIQ/T2020

MIQ/MC



Universal module housing

IQ System Components

Overview shows the individual components with their main functions:

Controller/Terminal

	System 184 XT	System 2020 XT
Central control unit	Combined terminal / Controller MIQ/C184 XT	Controller MIQ/MC - XX - YY with additional functions such as digital interfaces and automatic air pressure compensation
1st Terminal	Integrated in control unit	Separate terminal MIQ/T2020 (PLUS)

MIQ-Modules for both systems

Power supply	MIQ/PS for 100 – 240 VAC input voltage MIQ/24V for 24 VAC or 24 VDC input voltage; Parallel connection of up to 6 modules installed in one system
Output modules	MIQ/CR3 with 3 analog outputs and 3 relay outputs MIQ/C6 with 6 analog outputs MIQ/R6 with 6 relay outputs
Magnetic valve module	MIQ/CHV PLUS, magnetic valve module for automatically controlled air cleaning
Connection / junction box modules	MIQ/JB with 4 connections (for IQ Net or IQ sensors) MIQ/JBR, as MIQ/JB, with additional signal amplification for use with long cable lengths (> 1000 yds/1 km overall length)
Input current module	MIQ/IC2 with 2 inputs for 0/4-20 mA signals Enables inclusion of separate measuring transducers and analyzers in the IQ Net
Connection module for spectral probes	for connecting CarboVis®, NitraVis® and NiCaVis® probes
NEW Radio module	MIQ/Blue PS for wireless connection within the IQ SENSOR NET system
2nd and 3rd Terminal if additional display units are desired	Terminal MIQ/T2020 or Terminal MIQ/T2020 PLUS, if a redundant controller is desired to increase breakdown safety or Software terminal MIQ/IF 232, offers the full functionality of the hardware terminal MIQ/T 2020; additional functions: <ul style="list-style-type: none"> • Current measuring data transmitted to PC for further processing • Offline readout of stored values • View/save/open/print system configuration



IQ SENSOR NET

General Technical Data System 184 XT and 2020 XT

System	
Certifications	ETL, cETL (conforms with relevant UL and Canadian standards), CE
Electromagnetic compatibility	EN 61326, Class B; FCC Class A, EMC for indispensable operation
Integrated lightning protection	According to EN 61326 enhanced overvoltage protection for the entire system, implemented in each component
Connection medium cable	IQ SENSOR NET cable: SNCIQ or SNCIQ/UG (underground cable with additional PVC coating); 2-wire with shield; 2 x 0.75 mm ² ; Filler cord for easy connection of shield: 0.75 mm ² ; pressure resistant to 10 bar
Connection characteristics	Power supply and data transmission on these wires; Resistant to polarity reversal with respect to switched shield and inner conductor (no damage); Comprehensive EMC shield control; Cable topology within IQ SENSOR NET system as required, e.g. in the form of a line, tree, star, multiple star; Total cable length: max. 1.000 m (without signal amplifying), with signal amplifying module MIQ/JBR additional 1.000 m
Connection medium radio	Radio transmission with a range of 100 m (max. 300 m), nearly unlimited range with repeater islands
Connection characteristics	Data transmission, separate power supply necessary for each island

Controller/Terminal	
MIQ module coupling at rear	Combined mechanical and electrical connection, for rapid coupling to MIQ modules
Display	Graphic display: resolution: 320 x 240 pixel; visible area: 4.49 x 3.39 in. (114 x 86 mm), black/white, backlit
Control functions/function keys	5 operating keys: 3 master keys for functions: Measurement (M), calibration (C), set/system settings (S), 2 keys for: confirmation/switching menu O.K. (OK), Escape (ESC) 1 knob for rapid selection of software functions and input of alphanumeric values
Data logger	MIQ/C 184 XT: Data memory for up to 8,640 data sets; MIQ/MC: Data memory for up to 43,200 data sets
Electric supply	Directly via the IQ SENSOR NET when coupled to MIQ module
Ambient conditions	Operating temperature: -4 °F ... 131 °F (-20 °C ... +55 °C); Storage temperature: -13 °F ... 149 °F (-25 °C ... +65 °C)
Housing material	ASA (Acrylonitrile-Styrene-Acryloesterpolymer)
Protection rating	IP 66 / equivalent to NEMA 4X (not suitable for conduit connection)
Dimensions (W x H x D)	8.27 x 6.69 x 1.57 in. (210 x 170 x 40 mm)
Weight	Approx. 1.54 pounds (0.7 kg)

Modules	
MIQ module coupling at front	Combined mechanical and electrical connection for rapid docking and removal of the MIQ/T2020 (PLUS) terminal and the MIQ/C184 XT controller, and for docking additional modules
MIQ module coupling at rear	Combined mechanical and electrical connection for docking additional modules, a total of 3 modules as a stack mounted unit
Cable feeds	4 screw cable glands M 16 x 1.5
Terminal connections	Screw terminal strips Terminal area for solid conductors: 0.2 ... 4.0 mm ² Terminal area for flexible conductors: 0.2 ... 2.5 mm ² accessible by opening cover
IQ SENSOR NET terminal connections	Terminal connections for the IQ SENSOR NET are available on each module and can be used as required: - for connecting sensors - as an input/output or for looping through/branching of the IQ SENSOR NET cable
Other functions	Two LEDs, yellow and red, for monitoring the operating voltage of the IQ SENSOR NET; IQ SENSOR NET connection, resistant to reversed polarity; Integrated local identity function; Integrated switchable terminal resistor (SN terminator)
Electric supply	Directly via the IQ SENSOR NET
Ambient conditions	Operating temperature: -4 ... 131 °F (-20 ... +55 °C); Storage temperature: -13 ... 149 °F (-25 ... +65 °C)
Housing material	PC – 20 % GF (polycarbonate with 20 % fiberglass)
Protection rating	IP 66 / equivalent to NEMA 4X (not suitable for conduit connection)
Dimensions (W x H x D)	5.67 x 5.67 x 2.05 in. (144 x 144 x 52 mm)
Weight	Approx. 1.1 pounds (0.5 kg)

Sensors	
Mechanical connections for accessories	Connection slot; Connection screw thread G 1"
IQ sensor connection cable	Combined mechanical and electrical connection for rapid attachment and exchange of sensors. Consists of jack plug and pressure-resistant screw connection. Cable lengths: 5 ft. – 23 ft. – 49 ft. (1.5 m – 7.0 m – 15.0 m) / 65 ft. – 162 ft. – 324 ft. (20 m – 50 m – 100 m in sea water design) available. Storage temperature: -13 °F ... 149 °F (-25 °C ... +65 °C) Operating temperature: -4 °F ... 131 °F (-20 °C ... +55 °C)

Configuration and performance data

Model	Description	System 184 XT Number Min/Max	System 2020 XT Number Min/Max	Power- consumption / output / W
	IQ Sensors	1/12**	1/20**	
SensoLyt® 700 IQ (SW)	pH / ORP assembly			⇒ 0.2
TriOxmatic® 700 IQ (SW)	D.O. sensor			⇒ 0.2
TriOxmatic® 701 IQ	D.O. sensor			⇒ 0.2
TriOxmatic® 702 IQ	D.O. sensor			⇒ 0.2
TetraCon® 700 IQ (SW)	Conductivity sensor			⇒ 0.2
VisoTurb® 700 IQ	Turbidity sensor			⇒ 5.0 (without ultrasonic ⇒ 0.3)
ViSolid® 700 IQ	Suspended Solids sensor			⇒ 2.0
VARION 700 IQ	Combination sensor ammonium and nitrate (ISE)			⇒ 0.2
AmmoLyt® 700 IQ	Ammonium assembly (ISE)			⇒ 0.2
NitraLyt 700 IQ	Nitrate assembly (ISE)			⇒ 0.2
NitraVis® 700/X IQ (TS)	Optical nitrate probe with connection module MIQ/VIS			⇒ 7.0
CarboVis® 700/5 IQ (TS)	Optical COD/TOC/DOC/BOD/SAC probe with connection module MIQ/VIS			⇒ 7.0
NiCaVis® 700/5 IQ	Optical probe for measurement of nitrate and COD/TOC/DOC/BOD/SAC, with connection module MIQ/VIS			⇒ 7.0
	Modules	with x numbers of IQ SENSOR NET terminal connections		
	Power input connection module			
MIQ/IC2**	IQ / input current 2, module with 2 inputs for 0 / 4 - 20 mA signals	②	**each occupied current input is counted as IQ sensor	
	Connection modules	1/6	1/6	
MIQ/PS	IQ / power supply module for input power with wide-range power supply unit for 100 - 240 VAC input voltage	③		18 ⇒
MIQ/24V	IQ / 24 V module for input power with 24 VAC or 24 VDC input voltage	③		18 ⇒
	Output modules (mA, relays, magnetic valve)	A total of 36 output channels is available.	A total of 48 output channels is available.	
MIQ/CR3	IQ / current relay 3 module, with 3 analog outputs and 3 relay outputs each	②	Each module requires 6 output channels.	⇒ 3.0
MIQ/C6	IQ / current 6 module with 6 analog outputs	②	Each module requires 6 output channels.	⇒ 3.0
MIQ/R6	Module IQ/ Relais 6 with 6 relay outputs	②	Each module requires 6 output channels.	⇒ 1.5
MIQ/CHV PLUS	Modul IQ / Cleaning Head Valve for automatically controlled air cleaning	②	Each module requires 1 output channel.	⇒ 1.0
	Radio module			
MIQ/Blue PS	Module IQ/ Radio transmission for wireless connection within the IQ SENSOR NET system	③	user-defined	⇒ 0.6
	Connection- and branching modules			
MIQ/JB	IQ / junction box module	④	0/15	⇒ 0.0
MIQ/JBR	IQ / junction box repeater module	② + ②	0/2	⇒ 0.2
	Terminal, Controller			
	Terminal / Controller System 184 XT	1/1	not possible	
MIQ/C184 XT	Terminal / controller for System 184 XT			⇒ 3.0
	Terminal System 184 XT and 2020 XT	0/2	1/3	
MIQ/T2020	Terminal System 2020 XT / 184 XT			⇒ 3.0
MIQ/T2020 PLUS	as MIQ/T2020, with redundant controller function			⇒ 3.0
MIQ/IF232	IQ / software terminal module	③		⇒ 0.2
	Controller System 2020 XT	not possible	1/1	
MIQ/MC(-A)(-RS)	Modul IQ / Micro Controller	②		⇒ 1.5
MIQ/MC(-A)-PR	Modul IQ / Micro Controller	②		⇒ 3.0
MIQ/MC(-A)-MOD	with PROFIBUS- or Modbus-Option			
	For further Information see brochure "Product Details"			

*(+2.2 W per connected power supply/isolator)



System data IQ SENSOR NET

IQ SENSOR NET performance data

All components within the system require a specific electric power supply. Due to the enormous flexibility of the system, an infinite number of variations is conceivable. Therefore, a balance sheet must be drawn up after selecting the components. This is easily done by totaling the power consumption of the individual components and checking whether the sum exceeds the power provided by a particular power supply unit. If so, the available power can be increased by installing additional or more powerful power supply units.

Power consumption in Watts MIQ/PS	Number of power supply units
≤ 18 Watt	1 power supply unit
18 - 36 Watt	2 power supply units
36 - 54 Watt	3 power supply units
55 - 72 Watt	4 power supply units
73 - 90 Watt	5 power supply units
91 - 108 Watt	6 power supply units

Additional cable losses generally do not need to be taken into account for installations where the main consumers are near (<164 yds/150 m) the next power supply and the overall cable length does not exceed 437 yds (400 m). In systems with greater cable lengths, approx. 1 watt of power loss per additional 109 yds (100 m) of cable have to be considered. These standard values apply when using specified IQ SENSOR NET cable SNCIQ.

Example

Outlet measurement with the following parameters: turbidity, pH, dissolved oxygen, conductivity and temperature	Components:	Power consumption or power supply	One power supply unit MIQ/PS is sufficient for the complete system consisting of four connected sensors.
	MIQ/PS	+ 18.0 W	
	MIQ/C184 XT	- 3.0 W	
	MIQ/C6	- 3.0 W	
	VisoTurb® 700 IQ	- 5.0 W	
	SensoLyt® 700 IQ	- 0.2 W	
	TriOxmatic® 700 IQ	- 0.2 W	
	TetraCon® 700 IQ	- 0.2 W	
	Total Σ :	+ 6.4 W	

Multi-parameter monitor for any 4 parameters, with 6 analog outputs

MIQ/C184 XT
+ MIQ/PS
+ MIQ/C6
+ 4 IQ Sensors
6 x mA

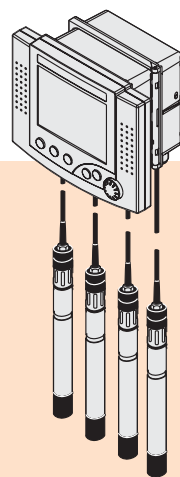

Features and functions

of the terminal/controller components



Mechanical docking of a terminal

A Terminal T2020 (PLUS) or Terminal/ Controller C184 XT can be easily connected to each module. The electrical contact for the power supply and data communication is made simultaneously with the mechanical connection.

Measurement display

The user can configure the measurement display by selecting between a single, four-fold or multiple view – depending on the number of connected sensors. The freely definable designation of the measuring location is included on each view for easy identification.

Stored measured data can be optionally displayed as measuring value lists, daily, weekly or monthly graphs. The respective current measured value can be displayed by following the curve with the cursor.



of the modules

Stack mounting of modules

Up to three modules can be mechanically connected to form a stack. Simultaneous mechanical and electrical connection to data and power transmission. The individual modules of the stack can be accessed at any time without dismantling the stack by simply undoing two lateral screws.

Distributed mounting of modules

(See the configuration examples on pages 71 to 73)

All modules can be installed anywhere in the system, both individually and in stacks. When not stacked, system components are connected via the 2-wire shielded SNCIQ SENSOR NET cable. Each SENSOR NET connection of a system component can be used to extend the IQ SENSOR NET cable. Furthermore, IQ sensors can also be connected directly to the SENSOR NET terminals.

Local identity function

The local ID function is integrated in each module in the form of a memory component. The memory can be used to store relevant information when configuring the system such as location or designation of the measurement location and the sensors connected there. When connecting a terminal, this information is output and facilitates rapid localization of sensors for calibration purposes.

Diagnosis via LEDs

Each module is provided with two LEDs (yellow/red) for diagnostic purposes. They are located on the side of the module and are clearly visible at all times. They indicate whether the respective module is operational (power supply/ data communication).

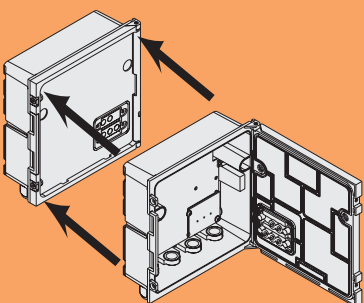



Configuration Options

Configuration Options for System 184 XT and 2020 XT

Due to the diversity of system versions, only a small selection of representative configurations can be shown here by way of example.

Example 1 System 184 XT

Configuration Example	Order No.
MIQ/S184 XT-H3	470 014
SACIQ-7,0	480 042
IQ Sensor	user selected

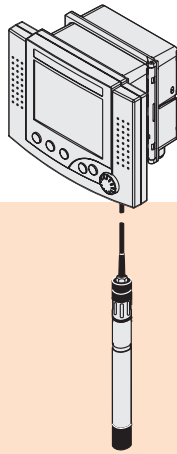

Starter set MIQ/S184 XT-H3 consisting of:

- MIQ/C184 XT (controller/terminal)
- MIQ/CR3 (3 x mA, 3 x relays)
- MIQ/PS (power supply)
- SACIQ (Sensor connection cable)
- IQ sensor

Monitor with 3 analog outputs and 3 relays, universally employable for all parameters

Example 2 System 184 XT

Configuration Example	Order No.
MIQ/S184 XT-H3	470 014
SACIQ-7,0	480 042
IQ Sensors	user selected

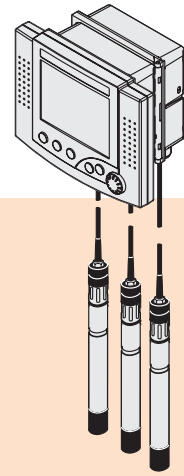

Starter set MIQ/S184 XT-H3 consisting of:

- MIQ/C184 XT (controller/terminal)
- MIQ/CR3 (3 x mA, 3 x relays)
- MIQ/PS (power supply)
- SACIQ (Sensor connection cable)
- IQ sensors

Multi-parameter monitor for any 3 parameters, with 3 analog outputs and 3 relays

Example 3 System 184 XT

Configuration Example	Order No.
MIQ/C 184 XT	480 001
MIQ/PS	480 004
MIQ/C6	480 015
MIQ/JB	480 008
SACIQ-7,0	480 042
IQ Sensors	user selected
MIQ/T2020	480 002
SNCIQ	480 046

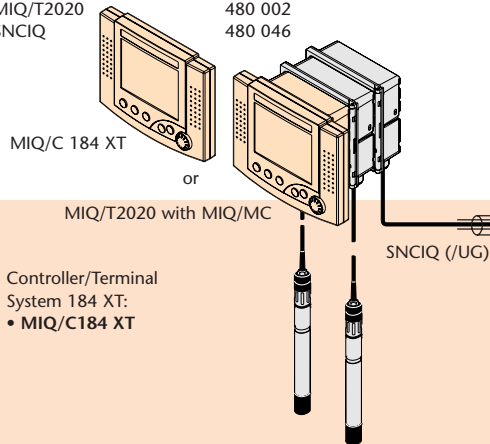

Controller/Terminal
System 184 XT:
• MIQ/C184 XT

System 2020 XT

Configuration Example	Order No.
MIQ/MC	471 000
MIQ/T2020	480 002
MIQ/PS	480 004
MIQ/C6	480 015
MIQ/JB	480 008
SACIQ-7,0	480 042
IQ Sensors	user selected
MIQ/T2020 PLUS	480 003
SNCIQ	480 046

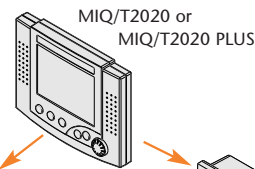

Controller + Terminal
System 2020 XT:
• MIQ/MC
(with different options)
• MIQ/T 2020

Branched System 184 XT (left column) and respectively 2020 XT (right column) for up to any 12/20 parameters. System with 6 analog outputs; measuring locations 2 and 3 are at a large distance from controller. Extendable by the mobile MIQ/T2020 terminal that serves as an additional display unit for easy on-site calibration or MIQ/T2020 PLUS with redundant controller function.

Configuration Options for System 2020 XT

Due to the extreme diversity of system versions, only a small selection of representative configurations can be shown here.

Control of 3 Aeration Basins with IQ SENSOR NET

Example with 2 options

Branched System 2020 XT with 12 measuring points; Power supply and controller with PROFIBUS interface are located in the control room nearby the PLC; Analog outputs/relays and redundant controller are used for additional security reasons.

The calibration station in the laboratory can be integrated in the complete system via radio transmission.

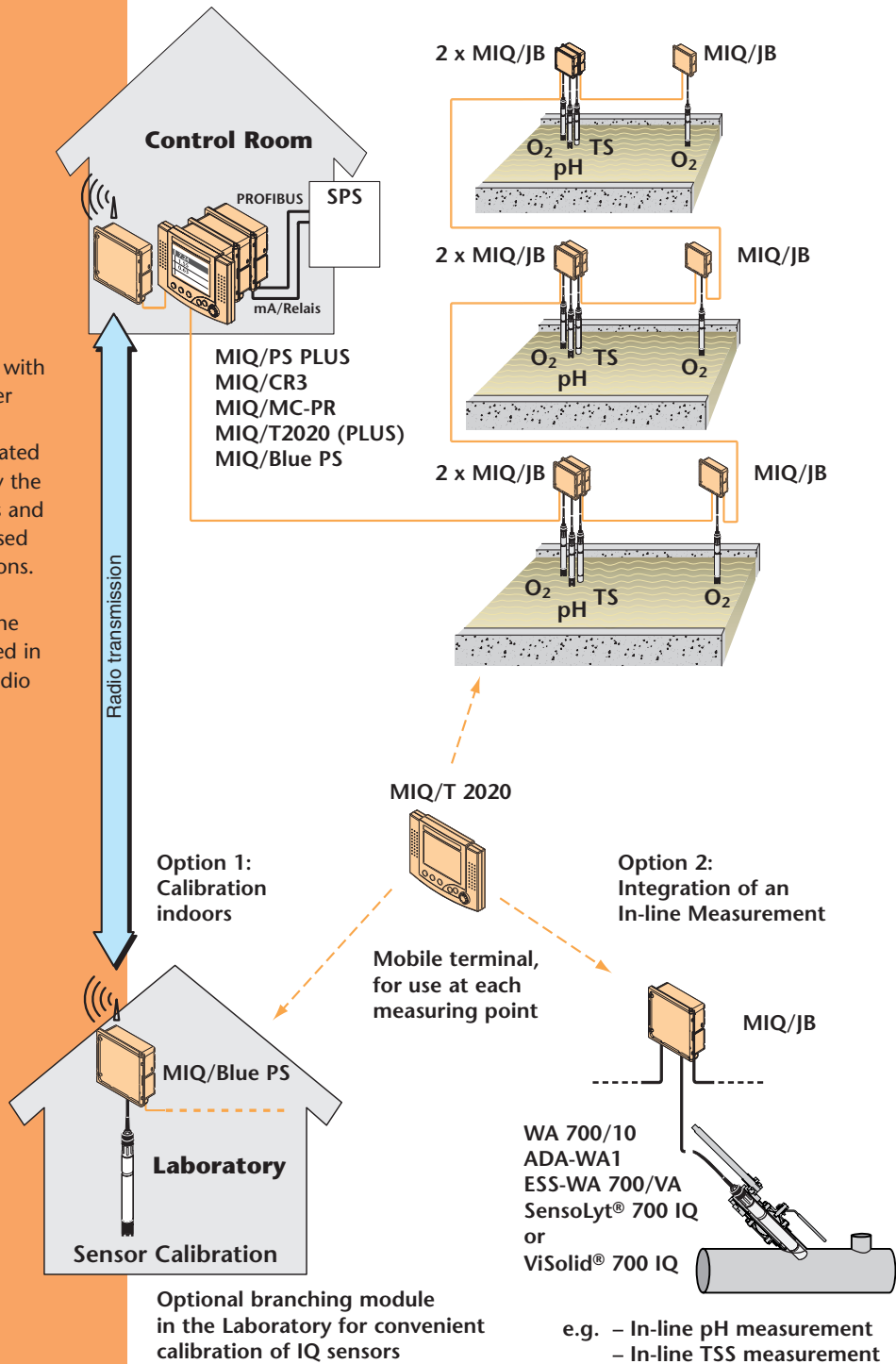



Integration of other Systems into the IQ Net

System 184 XT + 2020 XT:

Integration of external measuring points

Example 1: Integration of an Analog Monitor

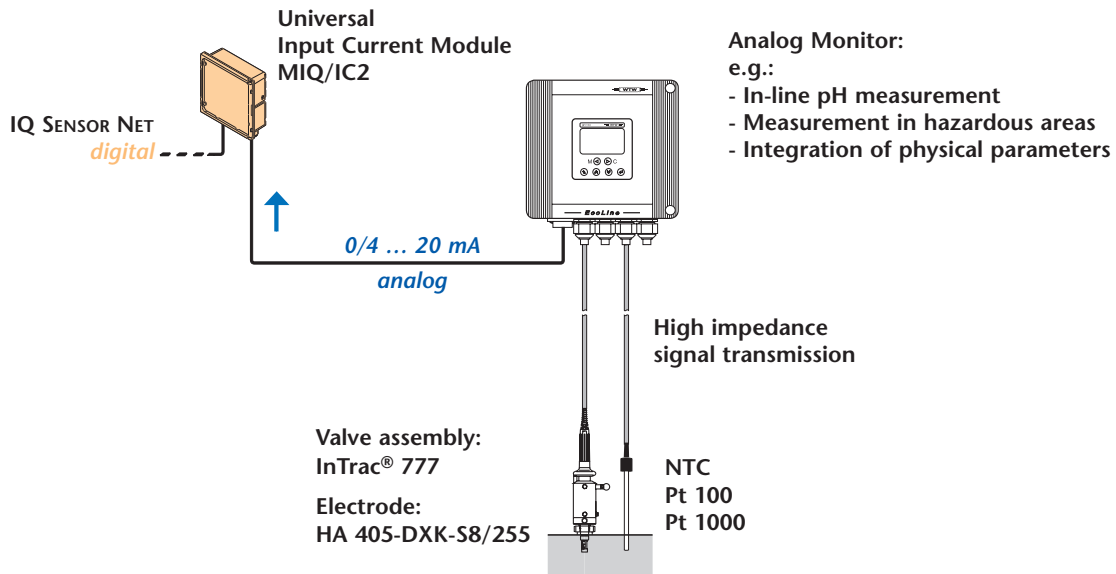

Example 2: Integration of an Analyzer

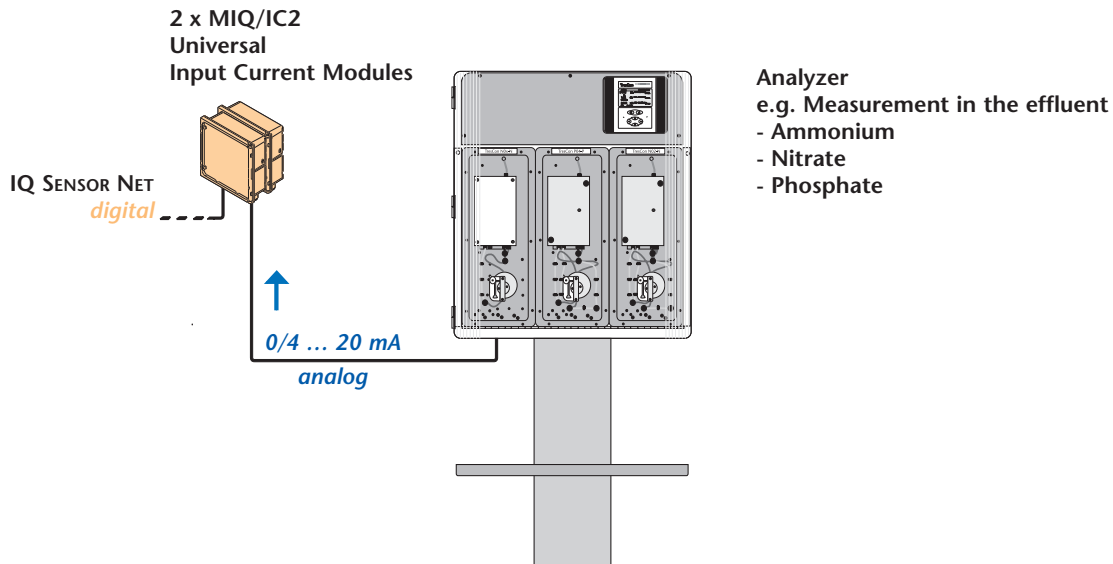

Communication with the IQ Net

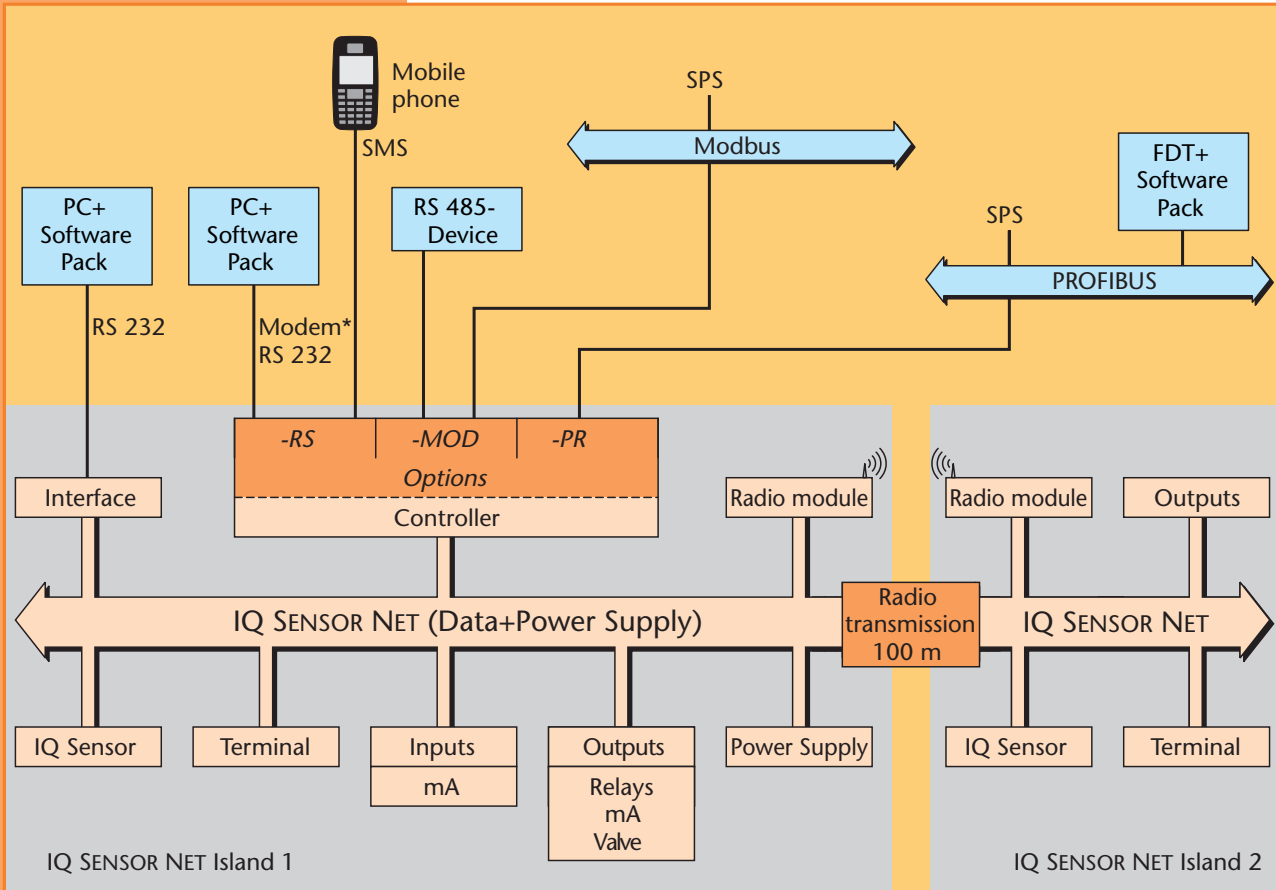

* Fixed line network, GSM or separate radio connection additional islands possible

With only one interface the data of all connected sensors can be transmitted: up to 20 main measured values plus secondary measured values e.g. temperature (all including status information).

Available are all digital interfaces shown in the above scheme (hardware in brackets):

PROFIBUS / Modbus:

- IQ SENSOR NET ➔ PROFIBUS DPV1 with FDT/DTM (MIQ/MC-PR) ➔ PLC/ etc. (with engineering tool)
- IQ SENSOR NET ➔ Modbus RTU (MIQ/MC-MOD) ➔ PLC/ etc.

RS 485

- IQ SENSOR NET ➔ RS 485 (MIQ/MC-MOD) ➔ PLC or PC

RS 232 – modem

- IQ SENSOR NET ➔ RS 232 (MIQ/MC-RS) analog or GSM modem ➔ fixed line telephone ➔ Analog modem or GSM modem on receiver side, with SMS function: alarms and measured values directly to the mobile phone
- ➔ or mobile network ➔ Modem for radio data transmission
- ➔ PC (WTW-Software)

RS 232 with suitable WTW-Software

- IQ SENSOR NET ➔ RS 232 (MIQ/IF 232) ➔ PC – WTW Software with different functions:

Functions of the WTW Software:

- Softwareterminal MIQ/T 2020 PC, Online connection, complete remote control of the IQ SENSOR NET
- DataServer, Online connection, transmission of current measured values to the PC (application example in Excel included), own programming easily possible
- DataTransfer, Online transmission of stored values to the PC
- Transmission of stored values in offline mode (MIQ/T2020 for temporary storage and MIQ/IF232 + MIQ/PS for transmitting the logged data to the PC)
- Saving, copying and printing of system configuration



Ordering Information Systems 184 XT and 2020 XT

		Order No.
IQ Sensors		
IQ Sensors	All IQ sensors are connectable; for ordering information see each parameter chapter	
Connection cable for IQ sensors		
SACIQ-1,5	Sensor connection cable for IQ, cable length 5 ft. (1.5 m)	480 040
SACIQ-7,0	Sensor connection cable for IQ, cable length 23 ft. (7.0 m)	480 042
SACIQ-15,0	Sensor connection cable for IQ, cable length 49 ft. (15.0 m)	480 044
An overview of all connectable sensors can be found in our brochure "Product Details".		
Terminal, controller, modules, accessories		
Terminal / controller, System 184 XT		
MIQ/C184 XT	IQ/Terminal and controller module for System 184 XT	480 001
Terminal, System 2020 XT / System 184 XT		
MIQ/T2020	IQ/Terminal module for System 2020 XT/184 XT	480 002
MIQ/T2020 PLUS	IQ/Terminal module for System 2020 XT/184 XT; with redundant controller function	480 003
MIQ/IF232	IQ/Interface 232 module for connecting a PC via the RS 232 interface incl. software terminal	480 020
Controller, System 2020 XT		
MIQ/MC	IQ/Micro Controller module	471 000
MIQ/MC-A	IQ/Micro Controller module with fully automatic atmospheric pressure compensation	471 010
MIQ/MC-RS	IQ/Micro Controller module with modem-capable RS-232 interface	471 001
MIQ/MC-PR	IQ/Micro Controller module with PROFIBUS-DP connection	471 002
MIQ/MC-MOD	IQ/Micro Controller module with MODBUS RTU/RS 485 connection	471 003
MIQ/MC-A-RS	IQ/Micro Controller module with fully automatic atmospheric pressure compensation and modem-capable RS-232 interface	471 011
MIQ/MC-A-PR	IQ/Micro Controller module with fully automatic atmospheric pressure compensation and PROFIBUS-DP connection	471 012
MIQ/MC-A-MOD	IQ/Micro Controller module with fully automatic atmospheric pressure compensation and MODBUS RTU/RS 485 connection	471 013
Power supply modules		
MIQ/PS	IQ/Power supply module for input power with wide-range power supply unit (100 – 240 VAC input voltage, ⇒ 18 W)	480 004
MIQ/24V	IQ/24 V module for input power with 24 VAC or 24 VDC input voltage, ⇒ 18 W	480 006
Connecting-/branching modules		
MIQ/JB	IQ/Junction Box module for system branching	480 008
MIQ/JBR	IQ/Junction Box Repeater module for system branching, with integrated bidirectional signal amplifier for cable lengths >1094 yds (1000 m)	480 010
Input current module		
MIQ/IC2	Module IQ/Input Current 2 with 2 inputs for 0/4 - 20 mA signals	480 016
Magnetic valve module		
MIQ/CHV PLUS	Modul IQ/Cleaning head valve for automatically controlled air cleaning	480 018
Output modules		
MIQ/CR3	IQ/Current Relay 3 module, with 3 analog outputs and 3 relay outputs each	480 014
MIQ/C6	Modul IQ/Current 6, with 6 analog outputs	480 015
MIQ/R6	Module IQ/Relais 6, with 6 relay outputs	480 013
Radio module		
MIQ/Blue PS SET	Module IQ/Radio transmission, for wireless connection within the IQ SENSOR NET system, SET with two pairwise preconfigured modules.	480 021
IQ SENSOR NET cable		
SNCIQ	Shielded two-wire IQ SENSOR NET cable for power supply and data transmission within the IQ SENSOR NET system; indicate length in m when ordering (unit: m)	480 046
SNCIQ/UG	Shielded two-wire IQ SENSOR NET underground cable for power supply and data transmission within the IQ SENSOR NET system; indicate length in m when ordering (unit: m)	480 047
Multi-parameter monitor MIQ/S 184 XT		
MIQ/S 184 XT-H3	Multi-parameter monitor consisting of the MIQ/C 184 XT + MIQ/CR3 + MIQ/PS components; 100 - 240 VAC supply voltage; 3 mA outputs and 3 relay outputs; up to 12 IQ sensors of any type can be connected	470 014
Mounting material		
SSH/IQ	Sun shield for mounting modules of the IQ SENSOR NET to Vario mounting stands	109 295
PMS/IQ	Kit for panel mounting of IQ SENSOR NET modules	480 048
THS/IQ	Kit for top hat rail mounting of IQ SENSOR NET modules	480 050
WMS/IQ	Kit for wall mounting of IQ SENSOR NET modules	480 052



TresCon[®]

TresCon[®] – Systematic On-line Analysis

For Continuous Monitoring and Process Control

- Simultaneous analysis of up to three parameters
- Mix or Match analysis parameters
- Easily upgradeable
- Ideal for monitoring
- Reliable & Accurate
- Consistent operation of all modules



As the need for higher quality measurements in water and wastewater plants increases so does the complexity and degree of automation. Practical and maintenance-free instruments to continuously monitor these processes requires

that those instruments be also rugged and efficient. The TresCon[®] Multi-parameter System exceeds all requirements for accurate and precise continuous measurements.



A Progressive Design Modular System

The TresCon®'s individual system components, the central control unit and the self-contained analyzer modules, have their own microprocessors which can perform specific tests independently.

The controller and the module communicate via high speed internal connections. Real-time control of the most difficult tests are easily accomplished with the TresCon®'s superior design. System can be custom designed to meet the operator's needs.

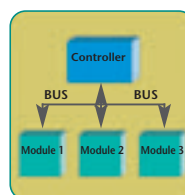

① System Controller Module

Equipped with a fast microprocessor, the controller includes a graphic display unit, a control panel and all the input/output interfaces. The controller inputs all application functions, calibration protocols, processing and storage of data and the display of measured results.)

If modules are added or exchanged TresCon will automatically recognize the new parameter and automatically updates the system. No operator servicing is required.

③ System Mounting

The stainless steel mounting column is an integral part of the TresCon® system. It is used for simple wall mounting and also contains the wide-range power supply for TresCon®.

② Analysis Modules

The analyzer modules are microprocessor-based, self-contained system components which will operate completely independent of each other. Up to three modules, in any combination of parameters, can be integrated into a single TresCon® system. The modules can be for the same parameter from different sample sites, or for any combination of the available parameters.

- NH₄-Module (Ammonium-Nitrogen)
- NO₃-Module (Nitrate-Nitrogen)
- NO₃/SAC-Module (Nitrate-Nitrogen and SAC)
- NO₂-Module (Nitrite-Nitrogen)
- PO₄-Module (Orthophosphate)
- ΣP-Module (Total Phosphorus)

Retrofitting or exchanging a module can be carried out in a few minutes. The new module is automatically recognized by the TresCon® controller and is immediately ready to use

④ Supplies Tray

A tray holds all bottles and containers for reagent, standard and cleaning solutions. The containers are color-coded so that parameters and connections can be easily connected.

TresCon®



Ammonium-Nitrogen

Nitrate-Nitrogen/SAC



Nitrite-Nitrogen

Orthophosphate



Total Phosphorus

General Description of Meters

Monitors

IQ SENSOR NET

Analyzer

Sample Preparation

Samplers

Accessories

Measuring stations





User Interface

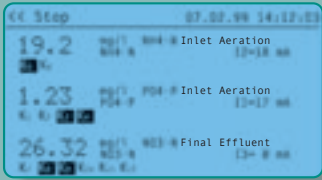

Simple Operation

- Uniform user interface for the complete system
- Uniform operation of all analysis parameters
- Clear and logically structured system program
- Rapid and safe input by 8 function and control keys
- Quick Start Guide/Instruction Manual

Easy-to-read information and graphical presentation

- High-resolution backlit graphics display
- Up to 3 measuring parameters at a glance
- Clear presentation of measurement, units, individual text and assigned relays and current interfaces
- Daily or weekly trend curves for individual or several parameters in a single graph
- Status line for auxiliary information

Auto Functions of All Modules

AutoClean®	An innovative method for automatic self-cleaning whose high efficiency allows measurements in slightly polluted wastewater, e.g. in sewage treatment plant effluent, without sample preparation.
AutoCal	Automatic calibration and plausibility check at predefined time intervals – resulting in a higher degree of accuracy.
AutoKorr	A correction algorithm developed by WTW for compensating background color in the sample in photometric measuring methods.
AutoFlow	Function for continuously monitoring the container filling levels and the sample/reagent flow in the module and for producing useful maintenance messages.
AutoTherm	Automatic temperature control means that ambient temperature influences on the analytical results can be disregarded.
Interval	Software function for regular measurements at selectable intervals.
Interval-Program	Measuring program – for a period of one week the measuring intervals within two-hour sections can be defined. This allows extremely reagent-saving operation in periods where experience has shown that only slight variations in the measurements are to be expected.

System Inputs & Outputs

TresCon® standard features include a number of analog and digital outputs, which provide enhanced data management and control capabilities of the system. All inputs and outputs can be assigned at will to the installed analyzer modules and freely configured.

Serial Interfaces

Two serial input/output interfaces which can be operated independently are standard equipment in the analyzer. While the RS 232, for example, is linked to a local device for data recording – such as a printer –, the RS 485 interface allows for remote control of the unit.

If a telephone connection is available then TresCon® can be accessed and controlled by a remote computer via the RS 232 interface and a modem. The RS 485 interface also allows TresCon® to be coupled to PROFIBUS-DP by using a gateway.

PID Control

As an alternative to outputting the measured values, the analog outputs of TresCon® can also be used as PID controllers for control and feedback control purposes.

Proportional Control (PW/PF)

As well as being used for report or limit contacts, each relay can also be programmed as an impulse or frequency controller. Depending on the control function, in I/F control either the impulse length (I-control) or the impulse frequency (F-control) of the output signal is varied.



TC/PU 1 Two-Channel Permeate Switcher

By means of the TC/PU 1 Two-Channel Permeate Switcher TresCon® can analyze samples from two different sampling locations in sequence. As the two analyzer samples, e.g. the permeate flows from two PurCon® systems, are directly in contact with the switching valve, any

alteration in concentration of either of the permeate flows can be registered within minutes. Up to three TresCon® modules can be connected to the TC/PU 1 Two-Channel Permeate Switcher. It is available as an accessory and can be mounted on the side of the TresCon®

stand in a space-saving manner. Control is via the TresCon® terminal. The mA outputs and relays can be parametrized accordingly so that no additional external reporting units are necessary.

Technical Data

Sample preparation	TresCon® analyzer modules require continuous sample input with a low solids content; typical sample preparation with PurCon® (see Sample Preparation Section).
Sample delivery	Sample presented for analysis in overflow vessels supplied; up to three analyzer modules can be connected to one overflow vessel. Operation with up to three overflow vessels is also possible (parallel analysis of different samples).
Interfaces	3 freely configurable galvanically separated 0/4-20 mA outputs, 12 potential-free relays, freely configurable, RS 232, RS 485.
Electrical connections	230 VAC ± 10%, 50 Hz / 115 VAC ± 10%, 50 – 60 Hz
Ambient conditions	Storage temperature – 77 ... 140 °F (25 ... 60 °C), operating temperature 32 ... 104 °F (0 ... 40 °C), climate class 4, VDI/VDE 3540 Bl. 2
Test marks	CE, DIN-GOST
Instrument protection	Safety class I according to IEC 1010-1/EN 61010-1
Weight	Empty housing: 59.5 lb (27 kg); each module: 22 lb (10 kg); mounting column: 55 lb (25 kg)

The technical data of the analyzer modules can be found on pages 37 to 57.

Ordering Information

One TresCon® basic instrument (without module) consisting of:	TresCon® terminal, mounting column, reagent tray, overflow vessels for max. three modules, terminal operating instructions (German) If operating instructions in English are required these must be ordered separately.				
TresCon® basic instrument (with first analyzer module)					
TresCon® Ammonia, A111	Basic instrument with OA 110 module for Ammonium-Nitrogen	8A-1	<input type="checkbox"/>	<input type="checkbox"/>	<input type="checkbox"/>
TresCon® Nitrate, N211	Basic instrument with ON 210 module for Nitrate-Nitrogen	8A-2	<input type="checkbox"/>	<input type="checkbox"/>	<input type="checkbox"/>
TresCon® Nitrite, N511	Basic instrument with ON 510 module for Nitrite-Nitrogen	8A-3	<input type="checkbox"/>	<input type="checkbox"/>	<input type="checkbox"/>
TresCon® Orthophosphate, P211/MB 1	Basic instrument with OP 210/MB1 module for Orthophosphate (measuring range 1)	8A-4	<input type="checkbox"/>	<input type="checkbox"/>	<input type="checkbox"/>
TresCon® Orthophosphate, P211/MB 2	Basic instrument with OP 210/MB2 module for Orthophosphate (measuring range 2)	8A-5	<input type="checkbox"/>	<input type="checkbox"/>	<input type="checkbox"/>
TresCon® Orthophosphate, P211/MB 3	Basic instrument with OP 210/MB3 module for Orthophosphate (measuring range 3)	8A-6	<input type="checkbox"/>	<input type="checkbox"/>	<input type="checkbox"/>
TresCon® Nitrate/SAC, S211	Basic instrument with OS 210 module for Nitrate-Nitrogen and SAC	8A-7	<input type="checkbox"/>	<input type="checkbox"/>	<input type="checkbox"/>
TresCon® Total Phosphorus, P511	Basic instrument with OP 510 module for Total Phosphorus (requires two module places)	8A-8	<input checked="" type="checkbox"/>	<input type="checkbox"/>	<input type="checkbox"/>
Ordering options for additional analyzer modules (2nd/3rd modules)					
Without additional analyzer module			<input type="checkbox"/>	<input type="checkbox"/>	<input type="checkbox"/>
NH ₄ analyzer module (Ammonia-Nitrogen), OA110			<input type="checkbox"/>	<input type="checkbox"/>	<input type="checkbox"/>
NO ₃ analyzer module (Nitrate-Nitrogen), ON210			<input type="checkbox"/>	<input type="checkbox"/>	<input type="checkbox"/>
NO ₂ analyzer module (Nitrite-Nitrogen), ON510			<input type="checkbox"/>	<input type="checkbox"/>	<input type="checkbox"/>
PO ₄ analyzer module (Orthophosphate), OP 210/MB1			<input type="checkbox"/>	<input type="checkbox"/>	<input type="checkbox"/>
PO ₄ analyzer module (Orthophosphate), OP 210/MB2			<input type="checkbox"/>	<input type="checkbox"/>	<input type="checkbox"/>
PO ₄ analyzer module (Orthophosphate), OP 210/MB3			<input type="checkbox"/>	<input type="checkbox"/>	<input type="checkbox"/>
NO ₃ /SAC analyzer module (Nitrate-Nitrogen and SAC), OS 210			<input type="checkbox"/>	<input type="checkbox"/>	<input type="checkbox"/>
Other ordering options					
Without feet (wall mounting with mounting stand)			<input type="checkbox"/>	<input type="checkbox"/>	<input type="checkbox"/>
With feet (free-standing arrangement)			<input type="checkbox"/>	<input type="checkbox"/>	<input type="checkbox"/>
Please complete the ordering number by entering the required versions:			<input type="checkbox"/>	<input type="checkbox"/>	<input type="checkbox"/>
Ordering example:	TresCon® Ammonium A111 with additional nitrate module, for wall mounting with mounting stand	8A-1	<input type="checkbox"/>	<input type="checkbox"/>	<input type="checkbox"/>



TresCon[®] Uno

Online-Analysis –

reliable · compact · economical

- Reliable TresCon[®] Technology
- Compact dimensions
- Economical
- Simple operation
- Easy to Use
- Easy Service Access
- Connection to PROFIBUS-DP possible



IP 54



2 Years Warranty

The new TresCon[®] Uno uses a single channel version of our popular multi channel TresCon[®] Analyzer.

The TresCon[®] Uno instruments are designed for control and monitoring at waste water treatment plants. The compact size of TresCon[®] Uno at a reasonable price offers to the user a good price-performance-ratio for the measurement of nutrient parameters.

System Description:

TresCon[®] Uno consists of a basic unit ①, an analyzer-module ②, and a reagent tray ③. System can be wall mounted.



Operation safe and Service friendly:

Many automatic diagnosis functions help the user with operation and maintenance. The modular design allows for the quick and easy exchange or replacement of modules.

Maintenance and Service

TresCon® systems are service-friendly requiring little or no maintenance. The numerous useful system functions are easily accessed and changed. The operator is also prompted as to service intervals automatically. It has also been designed for easy access and maintenance.

The Instruments include:

- big graphical display
- three 0/4-20 mA outputs
- 12 relay interfaces
- RS 232 interfaces
- RS 485 interfaces
- different controller functions (PID, pulse-width, frequency)

Connection to PROFIBUS-DP via Protocol Converter

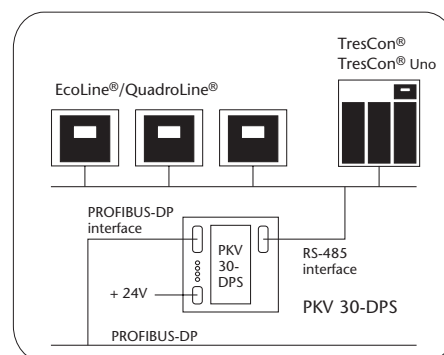

Technical Data

	TresCon® Uno		
Measuring ranges <i>Detailed technical data: see TresCon® modules in parameter sections*</i>	Ammonium:	0.05 ... 1000/1280	mg/l NH ₄ -N <i>*see also OA 110, page 41</i>
	Nitrate:	0.10 ... 60	mg/l NO ₃ -N <i>*see also ON 210, page 44</i>
	Nitrite:	0.005 ... 1.200	mg/l NO ₂ -N <i>*see also ON 510, page 45</i>
	Orthophosphate Range 1:	0.05 ... 3.00	mg/l PO ₄ -P <i>*see also OP 210, page 47</i>
	Orthophosphate Range 2:	0.10 ... 10.0	mg/l PO ₄ -P <i>*see also OP 210, page 47</i>
	Orthophosphate Range 3:	0.10 ... 25.0	mg/l PO ₄ -P <i>*see also OP 210, page 47</i>
	Nitrate/SAC:	0.10 ... 60	mg/l NO ₃ -N / 0.10 ... 200 m ⁻¹ <i>*see also OS 210, page 44</i>
Calibration	Automatic 2-point-calibration (works calibration for N211 and S211)		
Measurement intervals	Cont., 5, 10, 15, 20, 25, 30 min to be set depending on the parameter		
Sample preparation	Depending on the application: none, PurCon® or PurCon® IS		
Mains	230 VAC ± 10%; 50 Hz / 115 VAC ± 10%; 50/60 Hz		
Operation temperature:	32 ... 104 °F (0 ... 40 °C)		
Dimensions, weight (W x H x D, lb/kg)	Analyzer:	24.1 x 30.5 x 13 in. (612 x 775 x 329 mm), approx. 77.2 lb/35 kg	
	Reagent tray:	23.2 x 2 x 14.2 in. (590 x 50 x 360 mm), approx. 37.5 lb/17 kg	

Ordering Information

			Order No.
TCU/A111	TresCon® Uno - Ammonium	NH ₄ -N	820 101
TCU/N211	TresCon® Uno - Nitrate	NO ₃ -N	820 102
TCU/N511	TresCon® Uno - Nitrite	NO ₂ -N	820 103
TCU/P211-MB1	TresCon® Uno - Orthophosphate Range 1	PO ₄ -P/MB1	820 104
TCU/P211-MB2	TresCon® Uno - Orthophosphate Range 2	PO ₄ -P/MB2	820 105
TCU/P211-MB3	TresCon® Uno - Orthophosphate Range 3	PO ₄ -P/MB3	820 106
TCU/S211	TresCon® Uno - Nitrate/SAC	NO ₃ -N / SAC	820 107



On-Line Sample Preparation

Continuous · Reliable · Low Maintenance



Sample preparation is usually necessary for the reliable operation of on-line analyzers in municipal and industrial wastewater treatment facilities. Preparing the sample prevents solids and bacteria from contaminating the analysis system and its components. The sample preparation system and the analysis system must be matched to each other so that accurate and **continuous measuring operation** can be guaranteed together with low maintenance requirements.

In combination with a suitable sample preparation system, WTW analysis systems provide greater **operating reliability and availability**.

WTW Sample Preparation Systems

- **Biological Treatment**

For the most frequent application of on-line analyzers, their use in the biological treatment of wastewater treatment plants, WTW has developed the **PurCon®** sample preparation system. In contrast to preparation techniques based on the sedimentation principle, this low-maintenance system provides a constant flow of permeate.

- **Final Effluent**

For monitoring final effluent, WTW TresCon® Analyzers require **no sample preparation**. The TresCon®'s AutoClean® feature allows the treated sample to be measured directly.



PurCon®

PurCon®

Biological Treatment

PurCon® – the perfect sample preparation

PurCon® is a continuously operating sample preparation system which has been specially designed for use in wastewater treatment facilities. In contrast to conventional preparation systems, e.g. by sedimentation, the PurCon® unit provides a continuous flow of solid-free and bacteria-free permeate; BubbleClean® feature results in low maintenance requirements.

This sample preparation system is suitable for a wide range of applications in the wastewater treatment plants; even

for applications in the biological treatment with difficult-to-sediment sludge components.

The PurCon® sample preparation system is the ideal complement to the TresCon® analysis system as up to three on-line analysis modules can be supplied with permeate simultaneously.

In typical applications in municipal wastewater treatment plants, e.g. in the biological tank (3-6 g/l sludge), 6 months maintenance-free operation is possible.

System description

The PurCon® sample preparation system consists of a sample preparation unit and a control unit with peristaltic pump for permeate delivery. The unit is fully mounted and is built into a V4A stainless steel housing with a door in the front panel.



To supply the raw water to the PurCon® system a submersible pump is required; its type and size depend upon the local conditions. Sample discharge is pressureless (outlet diameter > 1.97 in./50 mm).

Sample Preparation



- Continuous sample preparation
- Solid-free and bacteria-free permeate
- Can supply up to three TresCon® analyzer modules
- BubbleClean®, self-cleaning feature – Low Maintenance

Technical Data PurCon®

Permeate	Feed to Analyzer	Continuous	 
	Yield	3.6 l/h max., adjustable in four increments	
	Quality	Free of solid matter and bacteria	
Sample delivery	Minimum ... maximum	400 ... 1.500 l/h approx.	
Connections	Sample inlet	Hose barb fitting, 3/4" I.D.	
	Drain outlet	PVC pipe fitting, 51.97 in. (50 mm) I.D., pressureless	
	Rinsing outlet	Hose barb fitting, 3/4" I.D.	
	Permeate outlet	Screw fitting, 0.06" dia.	
Electrical requirements	Voltage	230 VAC / 115 VAC (depending on version)	
	Power consumption	150 VA approx. (without pump)	
	EMC	According to EN 62 326 class B, Annex A, FCC class A	
Mechanical, protection rating	Dimensions (HxWxD)	2.38 x 1.86 x 0.71 ft. (735 x 575 x 220 mm)	
	Material	316 stainless steel; IP 33	
	Weight	36 kg, approx.	
Maintenance requirements	Municipal applications	Depends on location and wastewater load, typically 20 min / month	
Ambient conditions	Temperature	Storage: -13 ... 140 °F (-25 ... 60 °C) / Operating: 32 ... 104 °F (0 ... 40 °C)	
Certification		CE, TÜV-Mark, DIN-GOST	

Ordering Information PurCon®

PurCon/ 230	Sample preparation system for 230 VAC, with 1 m permeate tubing with adapter, 3 hose clamps for feed tubing	810 000
PurCon/ 115	Sample preparation system for 115 VAC, with 1 m permeate tubing with adapter, 3 hose clamps for feed tubing	810 008

For information visit www.WTW.com for a customer care center near you or inside US: call WTW 800 645 5999.

General Description of Meters

Monitors

IQ SENSOR NET

Analyzer

Sample Preparation

Samplers

Accessories

Measuring stations



PurCon® IS

Sample Preparation on-site with no external Pumps required

- Direct in-situ operation
- No external pumps required
- Continuous sample preparation
- Self-cleaning "BubbleClean®"
- Freeze protected permeate line



2 Years Warranty

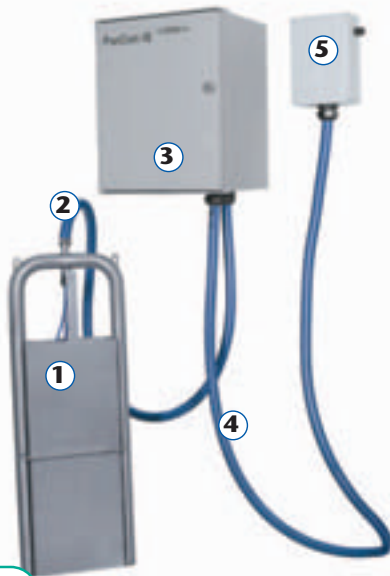

System description:

PurCon® IS consists of a filter unit ①, that is put directly in the sample, a suction hose ②, a control unit for outside mounting ③, that takes the permeate in and a permeate line ④ for the transport of the permeate to the analyzer units. The permeate line can – according to the ambient temperature conditions at the site – be specified with or without freeze protection.

At the end of the permeate line a box ⑤, is mounted that delivers the permeate.

Technical Data

Permeate stream sufficient for	PurCon® IS/2-230: supply of one TresCon® analyzer module PurCon® IS/4-230: supply of up to three TresCon® analyzer modules
Hose length	Suction hose: 5.47 yds (5 m) Permeate line 5.47, 10.94 or 21.87 yds (5, 10 or 20 m)
Operation temperature	-4 ... 104 °F (-20 ... + 40 °C); with freeze protection
Applications	Suited for outside operation
Mounting	Filter unit: Chain-, railing-, wall-, basin-, column mounting Control unit: railing-, wall mounting In combination with mounting sets and the WTW mounting system
Dimensions (B x H x T, lb/kg), weight, protection rating	Filter unit: 1.04 x 3.03 x 0.23 ft. (321 x 934 x 71 mm), 22 lb (10 kg), IP 68 Control unit: 1.34 x 1.66 x 1.12 ft. (412 x 513 x 345 mm), 33 lb (15 kg), IP 33

Ordering Information

		Order No.
PurCon® IS/2-230	PurCon® IS filter unit with 2 filter membranes, 5.47 yds (5 m) suction hose and control unit (230 V AC) for supply of one TresCon® analyzer module	810 050
PurCon® IS/4-230	PurCon® IS filter unit with 4 filter membranes, 5.47 yds (5 m) suction hose and control unit (230 V AC) for supply of up to three TresCon® analyzer modules	810 051
PCIS-Set115	Adaption set to 115 V AC mains supply	810 070
Permeate line – required for operation		
PCIS-PL5/H	5.47 yds (5 m), with freeze protection	810 065
PCIS-PL10/H	10.94 yds (10 m), with freeze protection	810 066
PCIS-PL20/H	21.87 yds (20 m), with freeze protection	810 067
PCIS-MSK	Set for chain mounting for PurCon® IS filter unit	810 071
PCIS-MSS	Set for bar mounting for PurCon® IS filter unit	810 072
PCIS-MSG	Set for bar mounting for PurCon® IS control unit	810 073
Further Accessories see brochure "Product Details"		

Secondary Sedimentation Stage / Final Effluent

In the effluent water from the secondary sedimentation the concentration of solids is often so high that sample preparation is required before on-line analysis can take place. In the effluent from wastewater treatment plant it is possible to carry out on-line analysis with TresCon® without any sample preparation as the analyzer module uses the AutoClean® method; this is a very efficient automatic self-cleaning system.

Final Effluent



PF105 Sample bypass

If TresCon® analyzers are used in slightly loaded wastewater such as wastewater treatment plant effluent the PF105 sample bypass is used to provide the analyzer module with unfiltered sample. The unit consists of a Y-shaped pipe branch with a valve for regulating the flow in the bypass. The supply to the TresCon® analyzer can be set with a second fine valve in the sample branch. To protect the TresCon® analyzer module coarse particles are retained by a woven-wire sieve in the branch.

Tubing connections:	20 mm dia.
Permeate tubing:	Length 1.09 yds (1 m), 0.24 in. (6 mm) I.D.
Feed:	1000 ... 1500 l/h
Branch:	Approx. 3 l/h
Dimensions (H x W):	1.28 x 1.07 ft. (395 x 330 mm)
Order No.	000 670

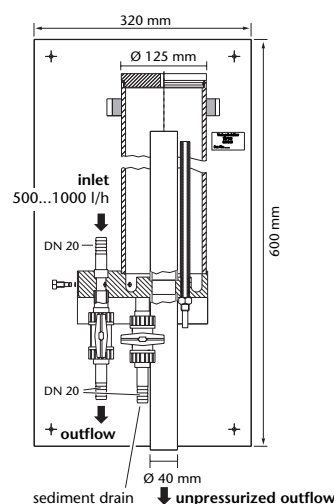

Overflow vessel VB 105

When using TresCon® analyzers for lightly loaded wastewater, e.g. in the effluent of wastewater treatment plants, the overflow vessel VB 105 with continuous sample flow is used to feed the analysis modules with non-filtrated sample. The unit is made up of a cylindrical vessel with a volume of approx. 2 l. This vessel is continuously being flown through and thus always supplies up-to-date sample.

Secondary Sedimentation

PurCon®

Apart from its use in aeration basins, the PurCon® system is ideal for the preparation of samples from the secondary sedimentation stage. In such cases PurCon® also continuously supplies an adequate amount of high-quality permeate. As only residual solids need to be removed from the sample, extremely low maintenance requirements are achieved.

Pumps and further Accessories see brochure "Product Details"



Sampling

Stationary · Portable

- Sewage Treatment
- Industrial Discharge
- Municipal Sewerage Systems
- Water Protection Control
- Process monitoring



Sampling is an important factor for the compliance with required regulations and efficient operation. It forms the basis for continuous monitoring of quality objectives and criteria, in particular for performance analysis of wastewater treatment plants. In addition, sampling systems are used increasingly for managing and optimizing complex production and recycling processes. In this context sampling represents the first link in the chain of work procedures for the examination and analysis of chemical, physical and biological parameters. It thus has a decisive, subsequently irrefutable, influence on results gained from chemical analysis.

Absolutely reliable provision of representative samples is extremely important, as they provide reliable and consistent assessment of contents and water properties.

The factors directly connected with sampling (sampling method, sampling location, sampling storage, sampling transport, sampling preservation and the method of analysis itself) have another important influential effect on the result. Consistent and exacting sampling is becoming increasingly significant due to the increase of required regulations.



Sampling

WTW has added two new units for precise sampling with the PB 8 and the PB 150-SE12 / -SE24. The PB 8 is a compact unit for plant monitoring. PB 150-SE12 / -SE24 is an automatic, self-emptying instrument for process monitoring.

Functionality

Sampling devices work according to the proven vacuum or peristaltic pump principle used in wastewater engineering. The vacuum dosing technology is particularly suitable for continuous stationary sample extraction. As sampling is performed only by means of vacuum or pressure, even heavily polluted wastewater with abrasive contents can be extracted safely and without wear.

In contrast, peristaltic pump technology is particularly suitable for short-term mobile sampling at different measuring locations.

Sampling procedure

Sampling is performed by non-pressurized extraction of either a single sample, a qualified sample, a 24 h composite sample or a 2 h composite sample from a lower level, e.g. from a basin, open channel or pipe under the following conditions:

Time

Constant sample volume, constant sampling frequency

Amount

Constant sample volume, sampling frequency variable according to throughput volume (0/4-20mA or flow impulse)

Flow

Sample volume variable according to throughput volume (0/4-20mA or flow impulse), constant sampling frequency

Event

Constant sample volume, constant sampling frequency,
Constant sample filling time or individual samples per bottle

Combination mode

Optional combination of time, amount and event sampling operation

General
Description of
Meters

Monitors

IQ SENSOR NET

Analyzer

Sample
Preparation



Samplers

Accessories

Measuring
stations



Technical Data Samplers

Sampling Mains operated	 PB 8	 PB 150-2	 PB 150-SE
Applications/ Specific features	Simple robust device for plant monitoring in water and wastewater Wall / Control panel mounting	Proven system for process and wastewater engineering, even for larger polluting load; Frame mounting	System for continuous, unmanned, "around the clock" monitoring. For process and water monitoring measuring networks. Self-emptying; Frame mounting
Installation site			
Permanent measuring place Outdoor installation	—	●	●
Frost-free roofed installation	●	—	—
Sample storage			
Thermostatic control / cooling heating	—	●	●
Passive cooling (IsoBox)	Option	—	—
Sampling system			
Vacuum system	●	●	●
Vacuum system Var	—	Option	Option
Self-emptying	—	—	●
Sampling method			
Time	●	●	●
Amount	●	●	●
Flow volume	—	Option	Option
Event	●	●	●
Combination mode	●	●	●
Communication			
RS 232	—	●	●
RS 485	—	●	●
System message display	●	●	●
System messages / signal outputs	—	Option	Option
Sample fractioning/ Composite sample			
Storage tanks 25 l	●	●	—
Storage tanks 50 l	●	●	—
12 x 1.1 l	IsoBox	●	—
2 x 10 l, 4 x 5 l	—	●	—
12 x 2 l	—	●	—
12 x 2 l glass	—	●	12 x 1,6 l glass
24 x 1.1 l	—	●	—
24 x 1 l glass	—	●	—
24 x 2 l glass	—	—	●



Sampling

Sampling Mobile operation



PB 25 S/ PB 25 S/24



PB 13



PB 17

Applications/ Specific features

Compact design for mobile water and wastewater plant monitoring

Modular system for mobile process and wastewater engineering tasks, even for large polluting load

Compact system with large sample capacity for examination series and load determination in the field

Installation site

Frost-free roofed installation

●

●

●

Power consumption

Battery

●

●

● pluggable

Power supply/recharger

●

external / buffer operation

external / buffer operation

Sample storage

Passive cooling (cooling accu.)

—

IsoBox

●

Sampling system

Vacuum system

—

●

●

Peristaltic pump system

●

—

—

Sampling method

Time

●

●

●

Amount

●

●

●

Flow volume

●

—

—

Event

—

●

●

Combination mode

—

●

●

Communication

RS 232

—

Option

Option

System message display

—

●

●

Sample fractioning/ Composite sample

Storage tanks 10 l PE

—

IsoBox

—

Storage tanks 13 l PE

●

●

—

Storage tanks 25 l PE

—

●

—

2 x 5 l PE

—

IsoBox

—

12 x 0.5 l glass

Option

—

—

12 x 1.1 l PE

●

IsoBox

—

12 x 1 l glass

—

IsoBox

—

24 x 1 l PE

—

—

●

Samplers for use in hazardous areas on request.



Sampling Stationary Samplers

Sampler PB 8 for plant monitoring

- Vacuum system
- Robust stainless steel version
- Flexible control system with progressive stages
- Continuous adjustment of sample volume
- Optional signal output for IsoBox / distributor



2 Years Warranty

Device system equipped with vacuum technology for frost-free roofed installation with mains supply. This robust and compact instrument contains proven components and is easy to operate. Controls were reduced to an absolute minimum. The operator guidance is menu driven showing all relevant parameters in the display. Thus providing a system which is fully sufficient for a multitude of tasks at a very favorable price-performance ratio. The addition of the IsoBox and cable connection accessory components provides the user with an inexpensive version for 2 h composite samples. With this powerful and reliable device, the operator has a low cost sampling instrument at his disposal which is reduced to core functionalities.



PB 150-2

- Vacuum system for operational safety, low maintenance
- Optimum sample thermostatic control and storage
- High quality completely stainless steel version
- Flexible control system with memory for user programs
- Sampling traceability through data memory and interface mode
- Separate control, energy and wet unit
- Optional flow proportional Var unit



2 Years Warranty

The instruments of the PB 150-2 series with their numerous versions are stationary samplers for permanent outdoor use under rough ambient conditions. The instruments are equipped with low maintenance and self-cleaning vacuum technology which has been field-tested and proven over years in the wastewater engineering sector. The devices are a further development of the PB 150 series and offer even more powerful and more economical sample storage with complete stainless steel fitting and a technically optimized temperature control system with a forced-ventilation liquifier. With its independent operation from the control system, the multiple point regulation system for cooling and heating the sample storage unit offers safe temperature control, even when the control system is turned off. In the light of representative samples for subsequent analysis combined with water content assessment, thermostatic control plays an important role. With its overall maintenance- and service-friendly equipment configuration with separate energy, control and wet area and its variable control system with memory for user programs, the device offers a high degree of efficiency and availability. The "Var" version with a variable dosing container is available for users who wish to combine flow proportional sampling with the advantages of vacuum technology. This patented version guarantees a reproducible sampling volume which corresponds to the individual flow volume (0/4-20mA) and permits digital sampling volume adjustment. Sampling can be traced using the display or fully documented and programmed using the communication software which is linked to a PC by an interface.





Stationary Samplers

PB 150-SE

For permanent stationary use in water and wastewater monitoring measuring networks, automatically self-emptying samplers are available from the PB 150-SE 12 series equipped with 12 or PB 150-SE 24 equipped with 24 sample vessels. These devices operate with proven low maintenance and self-cleaning vacuum technology. The sample vessels are available in glass (Duran 50) and are easily extractable for cleaning. The bottle is sealed and emptied by means of robust constriction hose valves. The fractioned sample in the device is automatically discarded (emptied) or manually extracted for analysis. Immediately after emptying a sample which is no longer required, the relevant bottle is rinsed with pressurized clean water before it is refilled. These devices can store up to 12/24 reserve samples without supervision. In case of serious disruption of operation or other events, event samples can be taken. The PB 150-SE devices are thus not only suitable for "around the clock sampling" for routine monitoring tasks, but also for event sampling or for a combination of both. Sampling is traceable by means of the program and error memory readout on the display or can be documented and programmed from a PC using the communication software.



- Automatic self-emptying
- Vacuum technology for operational safety
- Variable program navigation for routine and event mode
- Sampling traceability through program memory
- Documentation and programming via PC
- System monitoring
- Operation and error messages optional
- Optional flow-dependent Var dosing unit



Ordering Informations Stationary Samplers

		Order No.
PB 8-230 V	Sampler for wall mounting, 230V 50/60 Hz	000 167
PB 8-115 V	Sampler for wall mounting, 115V 50/60 Hz	000 169
PB 150-2/1	Sampler with thermostatic control for outdoor installation (25 l storage container), 230V 50/60 Hz	000 159
PB 150-2/R12	Sampler with thermostatic control for outdoor installation (12 x 2.9 l), 230V 50/60 Hz	000 162
PB 150-SE/12	Sampler, self-emptying, with 12 glass bottles (12 x 1.6 l), 230V 50/60 Hz	000 172
PB 150-SE/24	Sampler, self-emptying, with 24 glass bottles (24 x 2 l), 230V 50/60 Hz	000 174

Device alternatives and additional accessories see brochure "Product Details"



Sampling Portable Samplers

- Low maintenance vacuum system
- Large number of sample cycles with just one battery charge
- Robust stainless steel version
- Flexible control system
- Sampling is traceable on display

IsoBox

- Protected sampling
- Sample storage by means of insulated container
- Space for large volume cold storage accumulators
- Simple and safe transport

Portable Sampler PB 13

Portable sampler PB 13 with vacuum technology for universal applications. Thanks to its energy saving functionality, a large number of sample cycles or comprehensive sampling programs, respectively can be performed with just one battery charge. PB 13 can be mounted directly on all common storage containers or onto the IsoBox, which is available in different versions. When combined with IsoBox, it provides the user with a practical and modularly extendable system with passive cooling. IsoBox is not only suitable for temperature control of samples but also for safe protected sample transport.



Portable Sampler PB 17



The portable sampler PB 17 with vacuum technology and its immensely compact build is also suitable for field use in difficult terrain. With its large utilizable sample capacity of 24 x 1 l segment bottles, it is particularly suitable for extensive monitoring tasks and load determination. The lower part of the device has a double-wall insulation and offers full sample protection and a passive cooling facility with dry ice or cold storage accumulators. The cover, which is equipped with a lock, offers protection against the elements and unauthorized access. Its easy-to-change rechargeable battery with plug connection prevents downtimes caused by battery charging and facilitates a high level of availability.

- Energy saving vacuum technology
- Very compact build
- Large bottle capacity
- High level of availability through simple battery change





Portable Samplers

Portable Sampler PB 25 S / PB 25 S/24

Portable sampler PB 25 S with peristaltic pump technology, built-in rechargeable battery and charger for composite sample 13 l as well as differential sample via distributor to 12 x 1 l (optionally 24 x 0.5 l) sample containers. Precise sampling of waters with a very low degree of conductivity is possible by inductive water measurement which is directly linked to the control unit.



- Compact
- Time, amount, event and flow proportional sampling
- Precise inductive water measurement

Ordering Information Portable Samplers







		Order No.
PB 13		
PB 13	Portable microprocessor-controlled liquid sampler with vacuum dosing system and built-in rechargeable battery. Delivery includes 5 m suction tubing, screw fitting and tubing end piece. Not included: battery charger, sample containers or IsoBox. The required accessories for PB 13 must be ordered separately.	000 170
	IsoBoxes	
IsoBox/1	IsoBox complete with 1 x 10 l PE composite container, 2 cooling sets (sample distributor not required)	000 555
IsoBox/R2	IsoBox complete with 2 x 5.0 l PE sample containers, sample distributor, 2 cooling sets	000 556
IsoBox/R12	IsoBox complete with 12 x 1.1 l PE sample bottles, sample distributor, 2 cooling sets	000 557
IsoBox/R12G	IsoBox complete with 12 x 1.0 l glass sample bottles, sample distributor, 2 cooling sets	000 558
PB 17		
PB 17	Portable microprocessor-controlled liquid sampler in plastic housing with vacuum dosing system and built-in rechargeable battery. Delivery includes 5 m suction tubing, screw fitting, tubing end piece and 24 x 1 l PE sample bottles. Not included: battery charger. The required accessories for PB 17 must be ordered separately	000 175
	PB 25 S and PB 25 S/24	
PB 25 S	Portable sampler with peristaltic pump dosing system, built-in rechargeable battery and battery charger as well as turntable distributor for 12 sample vessels. Supplied with 2 x 2 m suction tubing with quick-release coupling, suction piece and wastewater cap. Not included: sample containers (must be ordered separately, for 12 x 0.5 l glass bottles insert EW/25/0.5 is also required)	000 103
PB 25 S/24	Portable sampler with peristaltic pump dosing system, built-in rechargeable battery and battery charger as well as turntable distributor for 24 sample vessels. Supplied with 2 x 2 m suction tubing with quick-release coupling, suction piece and wastewater cap. Not included: sample containers (must be ordered separately)	000 105
	Additional accessories see brochure "Product Details"	

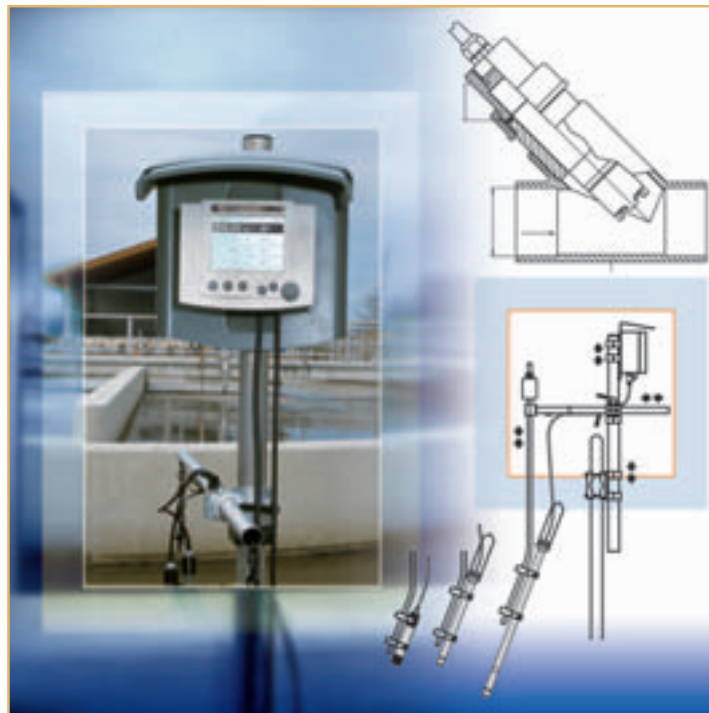

Accessories

Practical and Functional Components



-  Junction boxes
-  Sensor extension assemblies
-  Mounting hardware
-  Flow-thru adapters
-  Valve Assemblies
-  Cleaning System

For optimal configuration of the monitoring station, the instruments are supplemented by an extensive range of mechanical installation and assembly aids and useful accessories. These functional and practical tools provide the user with tailor-made and well thought-out solutions for almost every application.

All mechanical system components are manufactured from corrosion resistant materials. They are easy to assemble and completely maintenance free. The modular concept and the large design variety facilitate trouble-free adaption to the specific application requirements and installation circumstances.



Analog Junction Boxes

KI/S

Order No.: 108 606

This passive junction box is used for extension cabling between WTW sensors and the EcoLine and QuadroLine® series monitors.

KI/pH 170

Order No.: 108 596

Junction box with integrated impedance converter is designed to connect high impedance pH electrodes to WTW pH monitors over relatively long distances of up to 330 ft (100 m).

Analog & Digital Sensor extensions

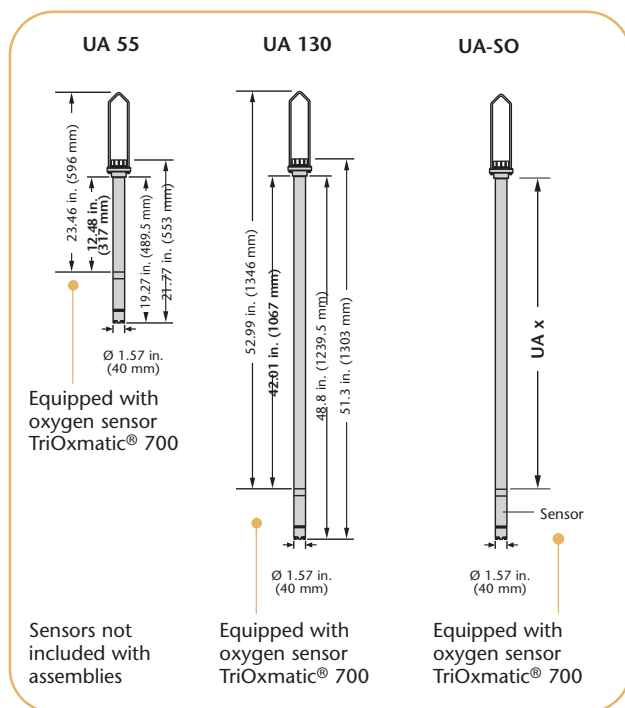

The universal extension assemblies made of PVC are used for mounting and mechanically protecting all 650, 690, 70X and 70X IQ series WTW sensors. The extension assemblies are available with two different standard lengths of armor; special armor lengths can be defined in your order. The assemblies are supplied with a stainless steel handle and a set of seals.

UA 55

Order No.: 109 260

Armored length without sensor 12.48 in. (317 mm).

UA 130

Order No.: 109 261

Armored length without sensor 42.01 in. (1067 mm).

UA-SO

Order No.: 109 263V

Armored length without sensor: stepless selectable between 9.45 and 102.36 in. (240 - 2600 mm).

Analog & Digital Sensor holders

EH/U 170

Order No.: 109 320

Single sensor holder

EH2/U 170

Order No.: 109 323

Twin sensor holder

EH3/U 170

Order No.: 109 325

Triple sensor holder

EH3/U 170

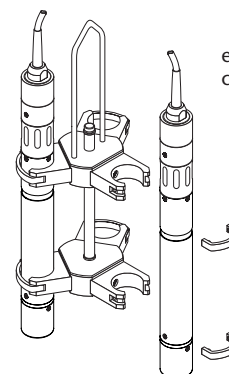

e.g. with mounted conductivity cell



Mounting Hardware

Installation Flexibility

The WTW mounting hardware constitutes a flexible mechanical system in which the individual components are optimally matched. With the selection and combination of various sensor holders, mounting stands and fastening elements, tailor made solutions can be established for the appropriate configuration of the measuring stations; as the diagrams show.

Measurements in Basins

Recommended sensor holding device:
Swing mounting assembly

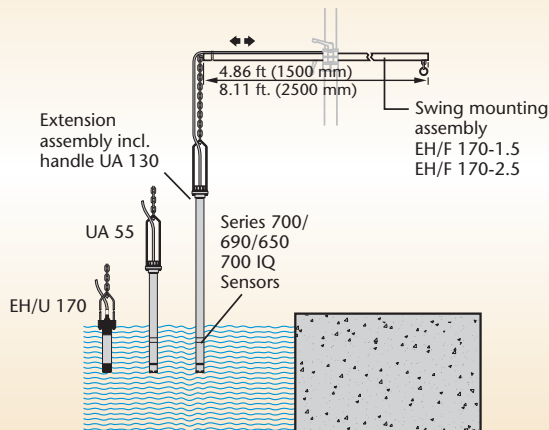

Measurements in Open Channels

Recommended sensor holding device:
Pendulum assembly

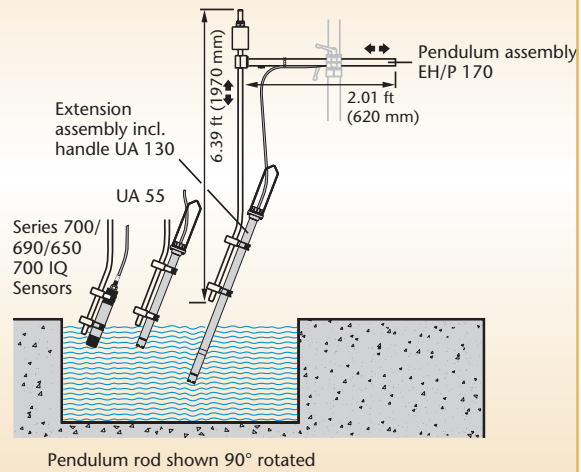

Measurements in Basins or in Open Channels

Wall mounting

for universal extension assemblies UA 55/ UA 130

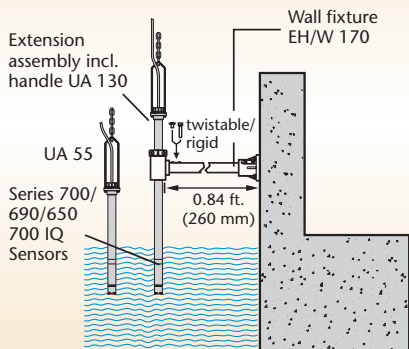

Measurements in very variable water levels or in rivers, lakes, etc.

Sensor Float S 200

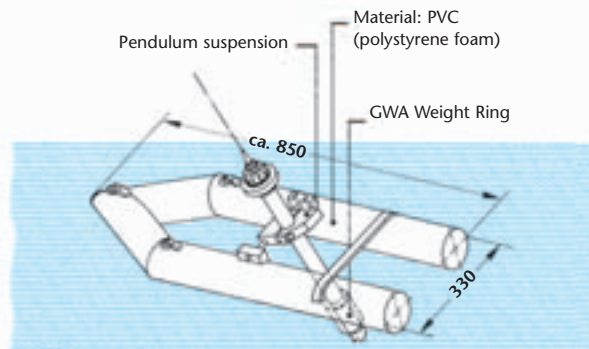



Mounting Stands and Fixtures

Details see page 98/99

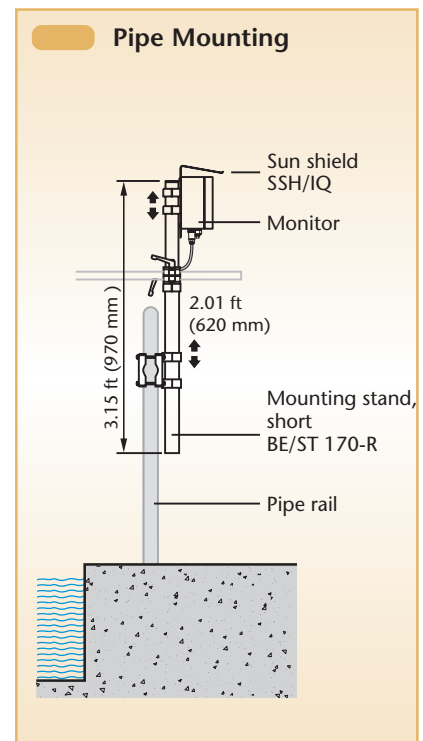
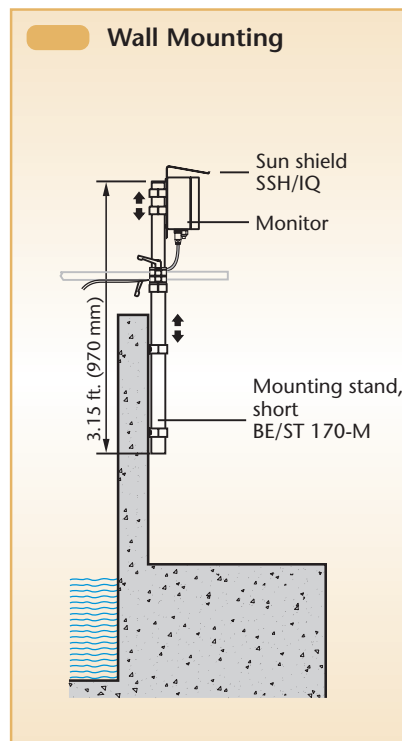
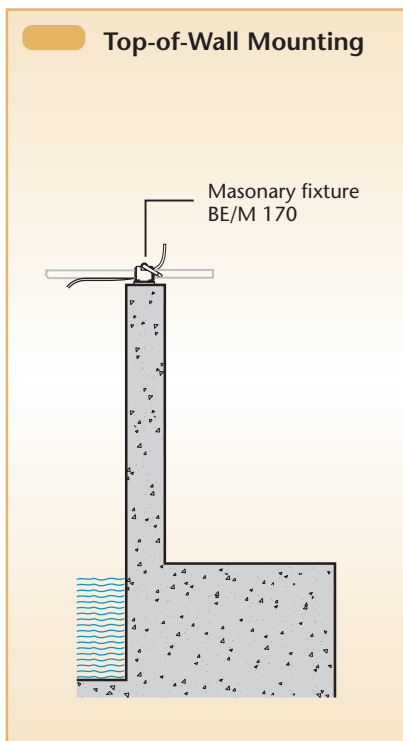
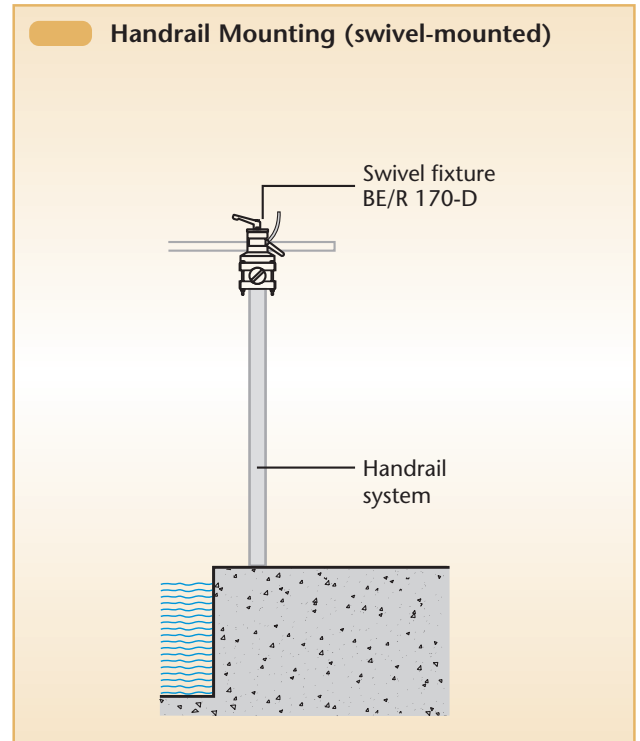
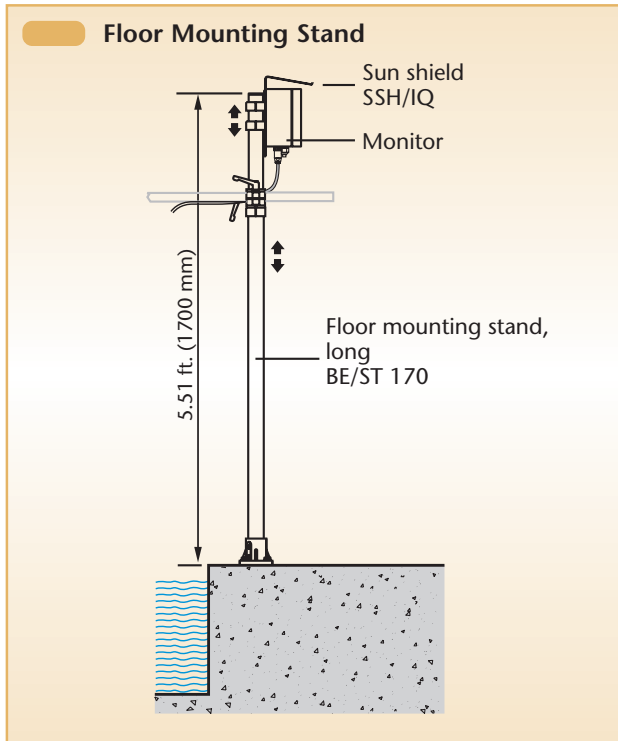



Sensor Holding Devices

EH/F 170

Order No.: 109 272, 109 273

The **SensoClean** swing mounting assembly consists of a 4.86 ft. or 8.11 ft. (1.5 or 2.5 m) long boom and a 13 ft. (4 m) long plastic chain for height adjustment of the sensor. It may also hold sensor extension assemblies. Particularly in turbulent flows, the freely swinging suspension produces a self-cleaning effect of the sensor, making the swing mounting especially suitable for operation in basins; e.g. in the aeration tank of a wastewater treatment plant.

Boom length:	4.86 ft. or 8.11 ft. (1.5 or 2.5 m)
Material:	Stainless steel 1.4301
Chain material:	Polyethylene

VIS Set-EH/F

Order No.: 480 056

Supplemental kit for horizontal mounting of a UV/VIS sensor (NitraVis®, CarboVis®, NiCaVis®). Suitable for basin or channel mounting in combination with swing mounting assembly EH/F 170.

Chain material:	Polyethylene
-----------------	--------------

EH/P 170

Order No.: 109 270

The **SensoClean** pendulum mounting assembly consists of a boom with a pendulum head and an angled pendulum rod. It is fitted at the top end with a movable counterweight for fine adjustment. The sensor or the extension assembly is fastened to the pendulum rod by two pipe clamps.

Boom:	Length 2.01 ft. (620 mm), stainless steel 1.4301
Pendulum rod:	Length 6.39 ft. (1970 mm), stainless steel 1.4301
Pendulum head, clamp:	POM/Polyethylene

EH/W 170

Order No.: 109 274

The EH/W 170 mounting assembly is designed for direct fastening to a wall of a basin. It can be set for pendulous or rigid operation, and it is suitable for extension assemblies. The immersion depth is adjusted by means of a fixing ring. Includes mounting plate with appropriate wall anchors and screws.

Boom:	Length 0.84 ft. (260 mm), stainless steel 1.4301
Pendulum head:	POM
Mounting plate:	Diecast aluminum

S 200

Order No.: 108 540

The float with pendulum mounting assembly is available for use in flowing water or where the water level fluctuates considerably. The fixture is designed for extension assembly UA 55. A GWA weight ring is also required.

Dimensions:	2.76 x 1.07 ft. (850 x 330 mm) (L x W)
Material:	PVC

VIS Set-S 200

Order No.: 480 054

Supplemental kit for horizontal mounting of a UV/VIS sensor (NitraVis®, CarboVis®, NiCaVis®). Particularly suitable for heavily fluctuating water levels in combination with the S 200 electrode float.

Material:	PVC/POM
-----------	---------

VIS Set-Inlet

Order No.: 480 058

Mounting set for horizontal mounting of a UV/VIS sensor in the inlet of a wastewater treatment plant. Especially developed for such muddy applications.

Dimensions:	Total height approx. 8.9 ft (2.75 m), boom approx. 4.8 ft (1.50 m)
Material:	PVC-U, stainless steel 1.4571

Vario Mounting Stand

BE/ST 170

Order No.: 109 280

Robust floor mounted stand made of stainless steel, with joint-locking fixture to accommodate a swing or pendulum mounting assembly and 2 pipe brackets for attaching a sun shield. With diecast aluminum baseplate, wall plugs and screws.

Stand:	Length 5.51 ft. (1700 mm), diameter 1.97 in. (50 mm)
Material:	Stainless steel 1.4301
Brackets:	Polypropylene

BE/ST 170-M

Order No.: 109 283

Mounting stand similar to model BE/ST 170, but shorter version for wall mounting. Wall mounting material is included instead of the baseplate.

Stand:	Length 3.15 ft. (970 mm), diameter 1.97 in. (50 mm)
Material:	Stainless steel 1.4301

BE/ST 170-R

Order No.: 109 281

This stand is similar to model BE/ST 170, but with hardware for fastening of the stand to a vertical or horizontal pipe rail.

Stand:	Length 3.15 ft. (970 mm), diameter 1.97 in. (50 mm)
Material:	Stainless steel 1.4301



Mounting Hardware

Fixtures

BE/R 170

Order No.: 109 278

With the BE/R 170 clamp set, a swing or pendulum mounting assembly can be fixed directly to a pipe; e.g. a handrail.

Material: Stainless steel 1.4301/
diecast Al/POM

BE/R 170-D

Order No.: 109 279

The swivel/pivot clamp fixture provides secure connection of a swing or pendulum mounting assembly to a horizontal pipe rail.

Material: Stainless steel 1.4301/
diecast aluminum

MR/SD 170

Order No.: 109 286

Mounting kit for sun shields, suitable for horizontal or vertical pipe rails with diameters of 0.98 to 2.36 in. (25 -60 mm). Sun shield not included.

Material: Stainless steel 1.4301

BE/M 170

Order No.: 109 276

With the BE/M 170, a swing or pendulum mounting assembly can be inexpensively installed directly at the basin edge or on top of a wall. It consists of a flange clamp with a clamping lever and a bolt-on base plate.

Material: Stainless steel 1.4301/
diecast Al/POM

BE/M 170 D

Order No.: 109 275

Wall mounting similar model BE/M 170, but pivoting version.

Material: Stainless steel 1.4301/
diecast Al



VIS Set-EH/F in use



VIS Set-Inlet in use

Sun Shields

SD/M 170-D

Order No.: 109 287

Stainless steel double sun shield for parallel mounting of 2 series 171, 170 measuring transducers and IQ SENSOR NET.

Dimensions: 10.55 x 21.42 x 5.91 in.
(268 x 544 x 150 mm)
(H x W x D)

Material: Stainless steel, 1.4301

SD/K 170

Order No.: 109 284

Sun shield for mounting a junction box or an IQ SENSOR NET module in the open air. Mounting kit MR/SD 170 is additionally required for attachment to vertical or horizontal pipes.

Dimensions: 5.59 x 9.06 x 3.43 in.
(142 x 230 x 87 mm)
(H x W x D)

Material: Stainless steel, 1.4301

SSH/IQ

Order No.: 109 295

Sunshield for mounting series 171, 170 and IQ SENSOR NET monitors on a Vario Mounting Stand.

Dimensions: 13.03 x 13.54 x 9.45 in.
(331 x 344 x 240 mm)
(H x W x D)

Material: ASA (Dust gray color)



IQ SENSOR NET under sun shield SSH/IQ



Flow-thru adapters and flow-thru vessels

WTW accessories can also be used for the recently introduced IQ SENSOR NET series. By the selection of a suitable adapter all the previous and new WTW sensors of the 690 and 70X (IQ) series can be mounted in the existing flow-thru adapters and vessels.

Flow-thru adapters

EBST 700-DU/N

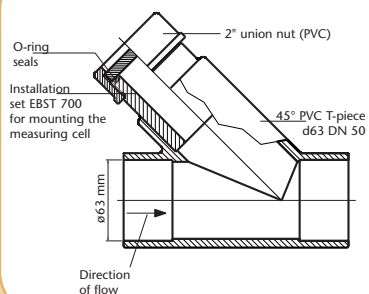

EBST 700-DU/N Order No.: 203 753

Flow-thru adapter for measurements in pipelines, consisting of a 45° PVC T-piece (d 63 DN 50) with bonded sleeve, O-ring seals and union nut. The adapter must be completed by the selection of a suitable sensor flange from the table on page 101 and can then be used for measurement of pH, oxygen, temperature and conductivity with all current WTW sensors.

Max. pressure:	3 bar
Max. temperature:	122 °F (50 °C)
Material:	PVC/POM

EBS 700-DU/N Order No.: 203 751

Mounting set for flow-thru measurements, consisting of a bonded sleeve for standard 45° PVC T-pieces (d 63 DN 50) or other suitable pipeline systems, one R 2" union nut and the necessary O-ring seals. Please select an adapter from the table on page 101.

Max. pressure:	3 bar
Max. temperature:	122 °F (50 °C)
Material:	PVC/POM

ESS 700 VA/N Order No.: 203 755

Stainless steel weld-in socket, for measurements in pipelines. Please select an adapter from the table on page 101.

Max. pressure:	3 bar
Max. temperature:	122 °F (50 °C)
Material:	
Weld-in socket:	V4A stainless steel 1.4571
Union nut:	PVC-U
Total length:	5.59 in. (142 mm)
Outside diameter:	2.36 in. (60 mm)

ESS 700 VA/10 Order No.: 203 757

Stainless steel weld-in socket, for measurements in pipelines. Please select an adapter from the table on page 101.

Max. pressure:	10 bar
Max. temperature:	140 °F (60 °C)
Material:	
Weld-in socket:	V4A stainless steel 1.4571
Union nut:	V4A stainless steel 1.4571
Total length:	5.59 in. (142 mm)
Outside diameter:	2.36 in. (60 mm)



ESS 700 VA/10



Flow-thru adapters and flow-thru vessels

Flow-thru Vessels

Oxygen Flow-Thru Measurement

D 702/N

Order No.: 203 747

In principle the flow-thru vessel D 702/N for continuous oxygen measurement can be fitted with all TriOxmatic® sensors of the 690/700/701 (IQ) series. However, it is primarily intended for oxygen measurements in the ppb range (TriOxmatic® 702 IQ), e.g. boiler feed water. In this application the flow-thru vessel is usually installed in the bypass of a water circulation system. Please select an adapter from the table (see below).

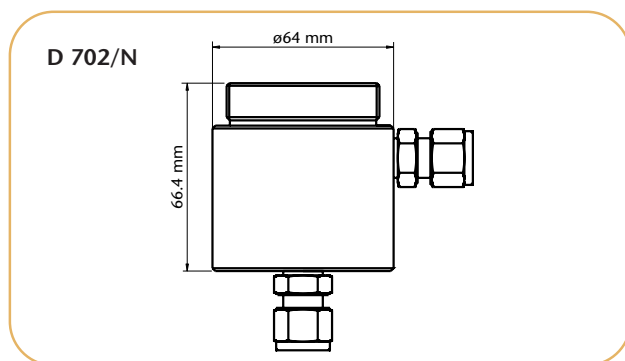

UV/VIS sensors in flow-thru measurement

VIS Flow-thru

Order No.: 480 059

Flow-thru cell for UV/VIS sensors NitraVis®/CarboVis® and NiCaVis® 700 IQ (TS).

The sensor can be cleaned automatically in mounted state by means of compressed air.

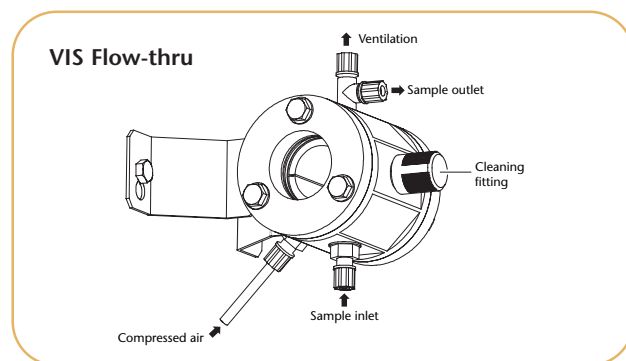

Technical details and further flow-thru vessels see brochure "Product Details".

Available flow-thru adapters with order numbers

Flow-thru vessel	EBS 700-DU/N	EBST 700-DU/N	ESS 700 VA/N	ESS 700 VA/10	D 702/N
	203 751 Flow-thru adapter	203 753 Flow-thru adapter	203 755 Weld-in socket	203 757 Weld-in socket	203 747 Flow-thru vessel
Sensor to be built in					
TriOxmatic® 690/700/700 IN/701 CelloX® 700 TetraCon® 700	ADA-DF 8 203 775	ADA-DF 8 203 775	ADA-DF 8 203 775	ADA-DF 12 203 783	–
SensoLyt® 690/700	ADA-DF 10 203 779	ADA-DF 10 203 779	ADA-DF 10 203 779	ADA-DF 13 203 785	–
VisoTurb 700 IQ ViSolid 700 IQ	ADA-DF 9 203 777	ADA-DF 9 203 777	–	–	–
TetraCon® 700 IQ SensoLyt® 700 IQ	ADA-DF 9 203 777	ADA-DF 9 203 777	ADA-DF 9 203 777	ADA-DF 11 203 781	–
TriOxmatic® 700 IQ/ TriOxmatic® 701 IQ	ADA-DF 9 203 777	ADA-DF 9 203 777	ADA-DF 9 203 777	ADA-DF 11 203 781	–
TriOxmatic® 702	–	–	–	–	ADA-DF 4 203 767 and ADA-DF 5 203 769
TriOxmatic® 702 IQ	–	–	–	–	ADA-DF 4 203 767 and ADA-DF 6 203 771
	– = Configuration not intended				



Retractable Armatures



Online measurements, of suspended solids in particular, are increasingly performed directly in pipework or pressurized containers. Retractable armatures are used in order to enable assembly and removal of sensors during ongoing operation without interrupting the process. Depending on working pressure, these require suitable assembly aids in order to re-insert the sensor against the working pressure.

The universally applicable structure is as follows:

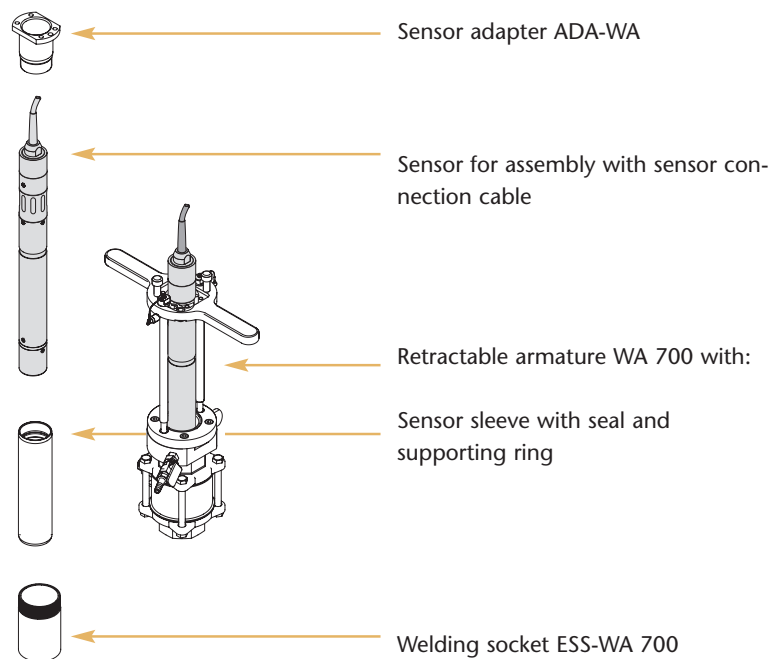

- Universally applicable
- For pressurized applications up to 10 bar (overpressure)
- Insertion and removal of sensor during ongoing operation

Apart from the two retractable armatures (for various pressure ranges) there are two different welding sockets (steel or stainless steel) and different matching adapters for mounting of the various online sensors with a shaft diameter of 1.57 in. (40 mm) available.

Ordering Information Retractable Armatures

	Sensor adapter	Order No.
ADA-WA 1	Adapter for mounting of IQ sensors	480 108
ADA-WA 2	Adapter for mounting of TriOxmatic® 690/70X, CellOx® 700 and TetraCon® 700	480 110
ADA-WA 3	Adapter for mounting of pH/ORP sensor assembly SensoLyt® 690/700	480 112
Retractable Armatures		
WA 700/10	Retractable armature for measurements in pipework, up to 10 bar (overpressure)	480 100
WA 700/2	Retractable armature for measurements in pipework, up to 2 bar (overpressure)	480 102
Welding socket		
ESS-WA 700/ST	Steel welding socket (St 33)	480 104
ESS-WA 700/VA	Stainless steel welding socket (1.4571)	480 106



Cleaning System

Some applications, in particular in the wastewater treatment, require special precautions for permanent and interference-free operation. The following components are required for a continuous compressed air cleaning system (components are highlighted in gray in the diagram):

- Cleaning head CH
- Valve module (MIQ/CHV PLUS or DIQ/CHV)

These components are required for the IQ SENSOR NET system. An additional power supply (e.g. MIQ/PS) is required for other measuring transducers.

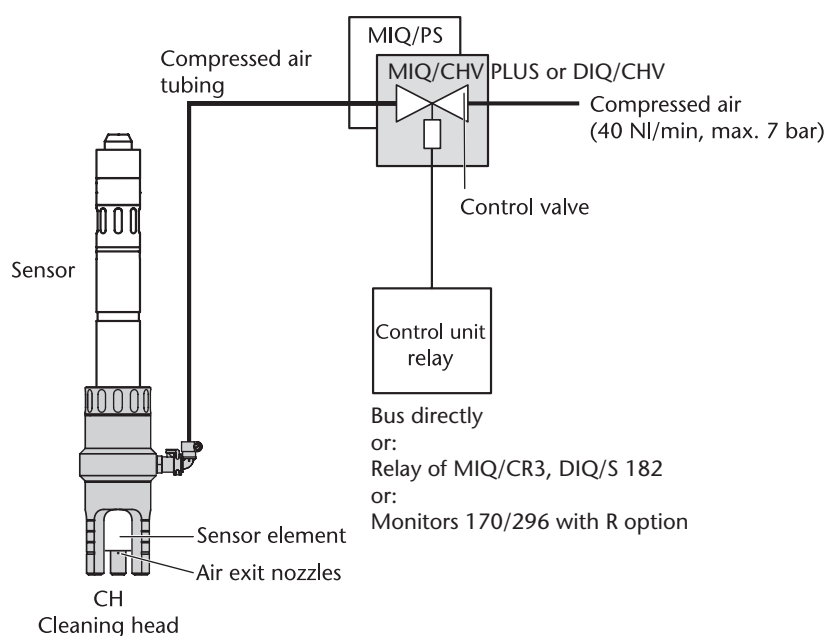

- Universally applicable
- Accessible directly via IQ SENSOR NET bus or via a relay at your choice
- Compressed air cleaning—winterized and interference-free

Efficient compressed air cleaning put into practice:



For cleaning, compressed air is blown at the sensor element (from external source) freeing it from pollutants. The compressed air is turned on and off by means of an electrically actuated control valve. For cleaning, the valve is opened for a certain length of time (duration of cleaning). The valve is activated time-triggered via the IQ SENSOR NET bus or via a relay of the measuring system.

Ordering Information Cleaning System

		Order No.
CH	Cleaning head with tube (16.4 yds/ 15 m)	900 107
MIQ/CHV PLUS	Valve module for cleaning system (IQ SENSOR NET, system 184 XT or 2020 XT)	480 018
DIQ/CHV	Valve module for cleaning system (IQ SENSOR NET, system 182)	472 007
MIQ/PS	Wide-range power supply	480 004

For information visit www.WTW.com for a customer care center near you or inside US: call WTW 800 645 5999.

General Description of Meters

Monitors

IQ SENSOR NET

Analyzer

Sample Preparation

Samplers

Accessories

Measuring stations



On-Line Monitoring and Control Stations

Mobile · Stationary · Remote



WTW manufactures fully instrumented, walk-in sheltered control stations for a variety of water and wastewater applications.

Project Planning

WTW engineers support the customers in the planning phase of even complex application solutions. The analysis and monitoring stations will be conceptually designed and engineered to optimally meet the customers' requirements, with particular regard to the situation at the project site and the expected operating conditions.

Installation

The fully assembled and self-contained station is transported as a turnkey unit to the project site and positioned on the foundation prepared by the customer. Minimal field assembly is then required by just connecting it to the main supply and the pipework.

Integrated, turn-key system solutions

Reduced risk of design errors by individual project planning





Monitoring and Control Stations

Portable, Battery Powered Measuring System

based on IQ SENSOR NET

WTW designs and manufactures fully assembled, compact and transportable measuring stations ideally suited for mobile field applications, but also for permanent installation. The standard instrumentation of the systems includes components of the IQ SENSOR NET system, the choice of the appropriate IQ sensors is determined by the particular application. For documentary purposes or evidence of pollution events, the collected data can be stored in a data-logger for later readout. Custom designed system configurations can be supplied to meet specific users' needs.

Features

- Robust water resistant housing equipped with an eyelet for carrying purposes with a chain or belt.
- Battery Powered. 4 weeks of continuous operation before recharging (Turbidity sensors or spectral probes will reduce the charging interval). Battery charger is included to delivery.
- Datalogger for 43.000 values (system 2020), means e.g. logging data with one sensor every minute for one month.
- Measured values (including date, time, temperature) can be downloaded to Excel via interface module.

Features

- Spot-checking for industrial discharger
- Trouble-shooting for polluted effluents
- Mobile pollution monitoring of water resources
- Pilot trials in treatment plants
- Planning studies for determination of process parameters
- Measurements in sewage influent streams
- Monitoring of aquacultural hatcheries
- Control system for transport of live fish



Sample Preparation Systems/Accessories

WTW supplies special accessories to meet specific users' demands.



PA-OP510/S

Sample preparation system for TresCon® Total Phosphorus analyzer. Homogenizers, sample beaker, control, valves and tubings are offered ready for use on a mounting plate.

Multiparameter Monitoring System

including flow section as complete unit on a mounting plate. Design can be individually adapted to the measured parameters.

Laboratory and Field Instrumentation

Are you interested?



Please order the new
WTW Catalog
"Laboratory and Field
Instrumentation"

Laboratory Meters

inoLab® p. 6

720/730/735/740/750

- pH
- ISE
- D.O.
- Cond
- Multi



Field Meters

p. 8

ProfiLine 197i

- pH
- D.O.
- Cond
- Multi



Handheld Meters

p. 9

315i/330i/340i/350i

- pH
- ISE
- D.O.
- Cond
- Multi



VARIO

p. 11

VARIO pH/C_{ond}

- pH
- Cond



Photometers

p. 80

photoLab® S6/S12/Spektral
pHotoFlex

- Photometrical
Tests

wide range
of tests
available



Turbidity Meters

p. 104

Turb 430 / 355 / 550 / 555
NTU



Respirometer OxiTop®

p. 62

OxiTop®/OxiTop® Control

- BOD
- Respiration

soil respiration,
biodegradation
OECD, Biogas
determination,
respiration rate





Environmental Monitoring

e.g. Photometric Measurements with pHotoFlex



see pp. 86



Swimming Pools

e.g. pH Control Measurement with pH 315i



see pp. 17

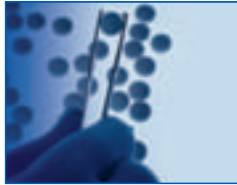

Pharmaceutical Water

e.g. Conductivity Flow Measurement with inoLab® Cond 730



see pp. 40



Food and Beverage Industry

e.g. Turbidity Measurement with Turb 430 + LabStation



see pp. 108



Chemical Water

e.g. pH/Conductivity/ISE Measurement with inoLab® pH/ION/Cond 750



see pp. 54



Cosmetics/Detergents

e.g. pH Measurement with VARIO pH



see pp. 18

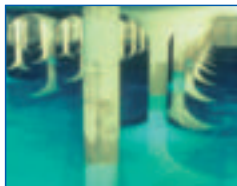

Groundwater

e.g. D.O./pH/Conductivity Measurement with Multi 197i



see pp. 56



Semi-Conductor Industry

e.g. pH/Conductivity Measurement with pH/Cond 340i



see pp. 60



Surface Water

e.g. D.O./pH/Conductivity Measurement with Multi 350i



see pp. 57



Process Technology

e.g. D.O./pH/Conductivity Measurement with Multi 340i



see pp. 60



Depths Profiles, Limnology

e.g. D.O./pH-/Conductivity Profiles with Multi 197i + Depths Armatures



see pp. 56



Laboratory Measurement

e.g. pH Routine Measurement with inoLab® pH 720



see pp. 14



Biotechnology (not autoclavable)

e.g. D.O./pH/Conductivity Measurement with Multi 350i



see pp. 57



Waste Water Treatment Plant: Aeration Basin

e.g. D.O. Control Measurement with Oxi 330i



see pp. 35



BOD Measurement

e.g. Dilution BOD with Analysis Program: inoLab® BSB/BOD 740; Self-Check Measurement with OxiTop®



see pp. 64



Biodegradation according to OECD

OECD 301: Determination with OxiTop® Control



see pp. 76



Fish Farming

e.g. D.O. Measurement with Oxi 315i and DurOx® incl. Protection Cap



see pp. 35



Wastewater: COD

e.g. COD Determination in Wastewater with photoLab® S12



see pp. 84



WTW

About us

Company highlights

- 1945** Company founded by **Dr. Karl E. Slevogt**
- 1948** Renamed to *Wissenschaftlich-Technische-Werkstätten (WTW)*
- 1954** Introduction of first WTW pH meter
- 1965** Introduction of first WTW oxygen meter
- 1976** Bavarian State Award for the **Combibox** compact multi-parameter system
- 1982** Introduction of the first zero-current-free (stable zero point) oxygen sensor for field measurements in the world
- 1983** Start of WTW's on-line measuring technology program
- 1986** First company to offer a 3-electrode oxygen sensor (**TriOxmatic®**) with automatic calibration on air (**OxiCal®**)
- 1987** First company to offer a 4-electrode conductivity sensor (**TetraCon®**) for portable water analysis
- 1993** First manufacturer of D.O., pH and conductivity measuring systems to be certified to ISO 9001
- 1995**
 - Introduction of the mercury-free **OxiTop®** system for manometric BOD determination
 - First company to offer monitors with built-in lightning protection
- 1997** New **photoLab®** laboratory photometers combine precision with outstanding ease of use
- 1998**
 - Introduction of the **PurCon®** sample preparation system as a replacement for conventional filtration systems
 - First WTW spectrophotometer
- 1999** "Innovations that make sense": the new laboratory instruments of the **inoLab®** family with their 3 function levels set new standards for the analytical measurement of pH, oxygen, conductivity and temperature as well as for ISE and multi-parameter measurements



Sean Donnelly, CEO WTW GmbH

There are not many companies around that can look back on 60 successful years. WTW is such a company, and one of the secrets of its enduring success is undoubtedly the permanent strive for top performance in the development and production of water analysis instruments. We are driven by our goal to offer complete solutions to make our customers work easier.

"To make good things even better" is one of the most difficult tasks one could imagine, but we believe there are always opportunities for improvement. This will be part of WTW's strategy for the next 60 or more years – take our word for it! Our customers and partners can look forward to new and innovative products in 2006 and beyond.

On-Line Instrumentation

The IQ SENSOR NET system is a flexible, digital based system providing from 1 up to 20 measuring points suited for - conventional instrumentation with analog outputs as well as for field bus instrumentation. The innovative digital sensors in this system represent the state of the art in process measuring systems. Our latest addition to the digital sensor offering is the NiCaVis™ product. This measurement system measures Nitrate and Carbon (COD), simultaneously in-situ.

The world's most complete line of pH/ORP, D.O., Conductivity and unique self cleaning Turbidity instrumentation. Complete systems, probes and accessories are available for measuring and monitoring water and wastewater.

TresCon™ Analyzers provide unparalleled modular flexibility and convenience for the on-line measurement and monitoring of up to three different parameters and uses the unique





About us

PurCon™ sample conditioning system for high accuracy and reproducibility in highly polluted wastewater samples.

The dependability, reliability, and versatility of WTW field proven Ammonia, Phosphate, Nitrite and Nitrate Analyzers, probes, and pH, ORP, D.O., and Conductivity systems and meters have established WTW products as industry standards world-wide.

Laboratory & Field Instrumentation

Offering the world's most complete line of pH/ORP, D.O./BOD/Respirometry and Conductivity Instruments, Turbidity Meters, Photometers with reagents, WTW systems range from rugged waterproof, hand-held, and portable field meters to an integrated line of laboratory instruments, supplies and accessories that include the new and innovative inoLab™ systems and a wide range of technically advanced Multi-parameter instruments that represent the state-of-the-art in measurement systems. Our latest innovation is the 350i Multi-parameter handheld meter. This product delivers pH, Conductivity, Dissolved Oxygen, and temperature measurements in a portable, water-proof system with a compact multi-parameter probe.

WTW has built a solid reputation in its 60 year history by providing "best in class" products with unparalleled customer and technical support. WTW strives to deliver solutions to our customers measuring problems. Our Customer Care Centers are dedicated to ensuring each customer's individual success. WTW's extensive applications library coupled with knowledgeable applications specialist provides for rapid resolution to technical challenges.



With support facilities around the globe, the WTW manufacturing center, located just south of Munich, Germany, delivers quality technical instrumentation with continuous support. We are proud to present our product offering to you and look forward to serving your needs.



Company highlights

2000 Introduction of **TresCon®** – the modular analytical system for the continuous measurement of ammonium, nitrite, nitrate, phosphate

2001

- **IQ SENSOR NET** – the multi-parameter measuring system offers unlimited possibilities for on-line measurements
- The new **VisoTurb®** and **ViSolid®** turbidity and solid sensors with their revolutionary ultrasonic keeping clean system give "low-maintenance" a completely new meaning

2002

- **AmmoLyt® 700 IQ** enables reliable On-line "in-situ" measurement of Ammonium
- **PurCon® IS: Sample Preparation** – directly without pump

2003 **NitraLyt 700 IQ** is a perfect supplementary nutrient parameter (Nitrate) for On-line "in-situ" measurement

2004

- Multi-parameter handheld meter **Multi 350i** represents state-of-the art in field applications
- **NitraVis®, CarboVis®** and **NiCaVis®** – spectral "in-situ" On-line sensors for combined Nitrate, Carbon and TSS measurement providing new solutions for waste water control

2005



- Portable photometers and turbidity meters for universal applications:
pHotoFlex/pHotoFlex Turb Turb 430 IR
- **IQ SENSOR NET System 182**
compact 2 channel transmitter as a supplement to the IQ SENSOR NET family
- **ECDO DO-Sensors**
Best for DO online measurement

2006 • **VARION** ammonium and nitrate multisensor with automatic compensation of interference ions



www.WTW.com & Contact

Looking for your local contact?

Here you can find your "local WTW":

contact addresses, representatives, distributors...

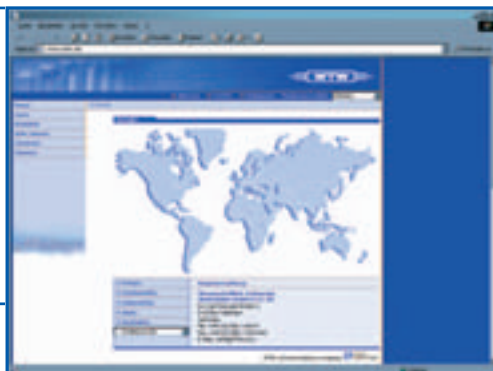

Click!



New Products

Click in – WTW presents its complete line of new products, innovative measuring and analytical instruments, helpful accessories, useful system extensions, special sets and much more –

24 hours a day..

-  Up-to-date
-  Informative
-  Multilingual

Information around the Clock!



Applications

WTW can provide you with a solution for all your measurement needs. In addition you will find tech tips, application notes,

and much more

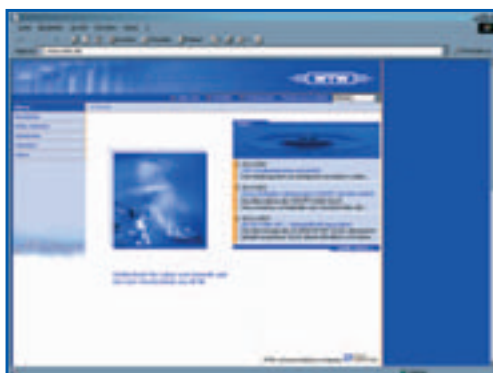

Downloads

You need a Manual, Application Report or a WTW Certificate?

Have a look at our Download Area...



Wissenschaftlich-Technische
Werkstätten GmbH
Dr.-Karl-Slevogt-Straße 1

D-82362 Weilheim

Germany

Tel: +49 (0) 881 183-0
+49 (0) 881 183-100
Fax: +49 (0) 881 183-420
E-Mail: Info@WTW.com
Internet: http://www.WTW.com



Important Information!

General information

1. Special versions of instruments on request.
2. Accessories and spare parts for older models – please make separate inquiry.
3. In order to avoid our customers having to pay a surcharge for small-volume purchases, we supply our consumables in practical minimum ordering quantities.

Technical alterations

The technical description corresponds to the current products.
Alterations because of technical improvements are possible.

Illustrations

We draw your attention to the fact that the illustrations are intended to clarify certain points. There may therefore be discrepancies between the illustrations and the written text.

Liability

We accept no responsibility for printing errors, writing errors or mistakes in the translation.

Edition January 2006

Publisher



Wissenschaftlich-Technische Werkstätten GmbH

Dr.-Karl-Slevogt-Straße 1

D-82362 Weilheim

Germany

Tel: +49 (0) 881 1 83-0
+49 (0) 881 1 83-100
Fax: +49 (0) 881 1 83-420
E-Mail: Info@WTW.com
Internet: <http://www.WTW.com>

