

IWAKI Magnetic Drive Pump

MX Series (MX-250~403)

Instruction Manual (Europe Edition)

 Read this manual before use of product

Thank you for selecting the Iwaki Magnetic Drive Pump MX Series. This instruction manual has been prepared to ensure correct and safe handling of the pump.

Please read this manual carefully and thoroughly prior to operating the pump.

Pay special attention to the "Safety Instruction to Prevent Personal Injuries," "Warning," and "Caution" messages included in this manual.

This instruction manual should be kept by each end user and within reach of the actual operator, for quick reference when needed.



Contents

Safety section	1~5
Outline of product	6~12
1. Unpacking and inspection	7
2. Principle of operation	7
3. Model identification code	8
4. Specification	9
5. Dimension	9
6. Name of parts and construction	10
7. Main parts and label	13
Installation	14~22
1. Before use	15
2. Installation	17
3. Piping	19
4. Wiring	22
Operation	23~27
1. Precautions on operation	24
2. Preparation for operation	25
3. Operation	26
Maintenance	28~41
1. Troubleshooting	29
2. Maintenance and inspection	32
3. Consumable parts	35
4. Disassembling and assembling	36



Safety section

For the Safe and Correct Handling of the Pump

- Before use of the pump, read carefully this "Safety Section" to prevent accidents and to avoid the damage or loss of other assets.
- Observe and abide by the instructions described in this "Safety Section". These instructions are very important for protecting pump users or other persons from hazard or from loss of assets.
- Meaning of symbols
Following two symbols describe the extent of hazards and loss which may brought if the instructions are not observed or if the pump is wrongly used.

 Warning	Nonobservance or misapplication of the contents of the "Warning" could lead to a death or heavy injury of person.
 Caution	Nonobservance or misapplication of the contents of the "Caution" could lead to a injury of person or damage of assets.

Following two symbols describe the content to be observed.

	Prohibited action or procedure is indicated. Inside or near this circle, a concrete activity to be prohibited is depicted.
	Action or procedure which must be performed without fail is indicated. Inside this circle, a concrete activity to be performed is depicted.

Safety section

Warning

- **Damaged or deteriorated tools are very dangerous.** Use qualified and suitable tools only.
- **Use of protectors:** When disassembling, assembling, and conducting maintenance or when handling a dangerous type of liquid or a liquid of unknown property, be sure to wear safety gloves, a helmet, and protective shoes. In addition, when handling wet-end parts, always wear protective goggles, masks, etc.
- **To prevent death or injury from a falling pump,** make sure the rope or chain used for lifting the pump is not accidentally cut or disconnected during installation. Make sure the rope or the chain used to lift the pump has sufficient strength in relation to the pump weight.
- **When lifting the pump with rope or chain,** be sure to use lifting bolts (or rings). Never use any other points for lifting the pump. Otherwise the pump may drop and results in human injury.
- **Always turn off the power supply prior to do maintenance or other works.** Make special provisions so that no other operator mistakenly turns on the power supply while someone is working on the pump. In a noisy or poor visibility environment, display a sign near the power supply switch to notify others that someone is "WORKING" on the pump. Power supply mistakenly turned on during maintenance may lead to personal injury.
- **Magnetic field hazard**
The magnetic drive pumps contain strong magnets which are located in magnet capsule and drive magnet cylinder. The powerful magnetic fields could adversely affect persons who are assisted by electronic devices such as pacemaker. etc.
- **When handling a toxic or odorant liquid,** ventilate the working area well. In addition, the operator must wear protector gear (such as a safety mask, safety goggles, and protective gloves).



Caution



Wear protective gear



Caution



Prohibited



Power off



Caution



Caution

Safety section

Warning

- **Plastic material parts (Casing, flange, baseplate)**

Do not hold plastic material parts when you lift the pump. Otherwise plastic parts may be broken and pump may drop resulting in human injury.



- **No remodeling**

Remodeling of the pump by the user may result in serious personal injury, electric shock, or damage to the pump. Do not attempt remodeling as it is very dangerous.



No Remodeling

- **Cautions when dangerous liquids are transferred.**

When the pumps are used to transfer the dangerous liquids mentioned as below, the pumps always must be checked and watched so that the liquids can not be leaked. The operation of the pumps leaking the liquids may result in personal injury and/or explosion, fire accidents.



- Explosive and inflammable liquids
- Corrosive and toxic liquids
- Liquids harmful to human body

Caution

- **Qualified operators only**

The pump operator and pump operation supervisor must not allow any operators who have little or no knowledge of the pump to run operate the pump. Pump operators must have a sound knowledge of the pump and its operation.



- **For specified application only**

The pump is designed and manufactured to the specifications agreed upon by the user and Iwaki. The use of a pump in any application other than those clearly specified may result in injury or damage to the pump. Use the pump strictly in accordance with the pump specifications and application range. If you change any specification, contact Iwaki or your dealer.



Prohibited

- **Run the pump at the specified power supply voltage indicated on the nameplate.**

Otherwise, pump failure, fire or electric shock may result.



Prohibited

- **Spill-out prevention measures**

Suitable protective measures should be taken against any liquid spill-out accidents. Never discharge hazardous liquid, including, but not limited to, chemical liquid, over the ground or floor on the pump operating site. Follow local rules and regulations in disposing of hazardous substances.



Caution

Safety section

Caution

- **Do not operate the pump dry.**

Do not run the pump dry (without liquid inside the pump). Heat generated as a result of abrasion between elements inside the pump during operation without liquid may damage the inside of the pump. Operating the pump with the suction valve fully closed will result in dry operation.



- **Keep away from heat or flame.**

Do not place any open flame or flammable object near the pump.



- **Do not stand on the pump.**

Do not stand on the pump or use the pump as a step under any circumstances. Otherwise, you may experience a serious injury.



- **Do not touch the pump.**

When the pump is used to feed a hot liquid, do not touch the pump or the piping with your bare hands during and immediately after operation as their surfaces are dangerously hot.



- **Arrange grounding**

Do not operate the pump without connecting the grounding wire. Otherwise, an electrical shock may result. Make sure the grounding wire is connected with the grounding terminal.



- **Install an earth leakage breaker**

The operation of a pump without using an earth leakage breaker may cause an electrical shock. Please install an optional leakage breaker in the system.



- **Do not install or store the pump in the following places.**

- Places where flammable gas, dust or material is used or placed.
- Places where corrosive gas (chlorine gas or the like) is generated.
- Places where the ambient temperature is extremely high (40 deg. C or higher) or extremely low, 0 deg. C or lower.
- Places where the pump is exposed to extreme dust or humidity. (Excluding the outdoor type)
- Places where vibrations occur.



- **Pump start-up**

When connecting a power supply to the pump, make sure there is no person around the pump. The pump has no ON/OFF switch. The pump starts operation when the power is supplied by connecting the power supply cable.



Safety section

Caution

- **Foreign matter**

Should foreign matter enter the pump, turn off the power at once and remove the obstruction. Using the pump with foreign matter inside may cause damage to the pump or a malfunction.



- **Disposal of used pump**

Disposal of used or damaged pumps must be done in accordance with local laws and regulations. (Consult a licensed industrial waste products disposing company.)



- **Strong magnetic power**

The magnet used in the pump has a very high magnetic power. Be careful not to allow your fingers to be seized by the magnet or to allow the magnet near any electronic device which may be affected by the magnet's power.



- **When suspending pump operation for a prolonged period**

When suspending pump operation for a prolonged period, drain and clean the pump. Take appropriate measures to prevent the foreign matter getting into the pump. If the pump is not operated for a period longer than one year, replace the O ring and inspect the pump inside.



- **Countermeasure for static electricity**

When low electric conductivity liquid such as ultra-pure water and fluor inactive liquid(e.g. Fluorinert™) are handled, the static electricity may be generated in pump, which may cause static discharge and break down of pump. Take countermeasure to avoid and remove the static electricity.



- **Ventilate**

When toxic and odorous liquid is handled, ventilate the site to avoid poisoning.



OUTLINE OF PRODUCT

<i>1. Unpacking and inspection</i>	<i>7</i>
<i>2. Principle of operation</i>	<i>7</i>
<i>3. Model identification code</i>	<i>8</i>
<i>4. Specification</i>	<i>9</i>
<i>5. Dimension</i>	<i>9</i>
<i>6. Name of parts and construction</i>	<i>10</i>
<i>7. Main parts and label</i>	<i>13</i>

1. Unpacking and inspection

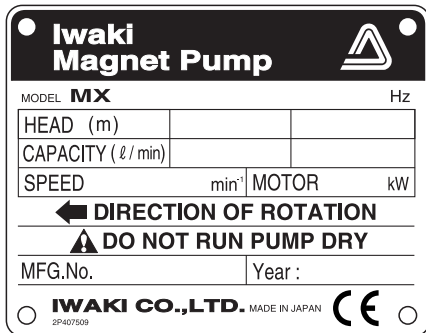

After unpacking, check the following points to confirm that the delivered product and its accompanying parts and elements are exactly what you ordered.

When lifting the pump please follow the procedure mentioned "2. Installation" of "Installation" on page 17.

- [1] Do the model and frequency indicated on the nameplate conform to your order?
- [2] Has the pump unit or any part of it been damaged or have bolts and nuts been loosened during delivery?
- [3] MFG.No. shows the year the product was manufactured.

(e.g.1) When first numeral is "7".

7××2×××

The forth numeral of MFG.No. shows the product was manufactured.

"2" shows the product was manufactured in the year 2002.

(e.g.2) When first numeral is not "7".

××2×××

The third numeral of MFG.No. shows the year the product was manufactured.

If you find anything wrong, please refer to the dealer you placed your order with.

2. Principle of operation

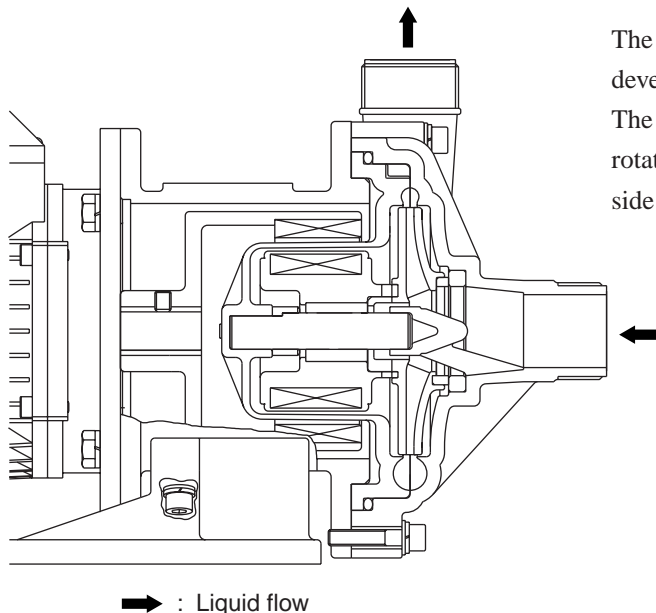

The MX pump is a magnet-driven centrifugal type pump developed for various applications.

The impeller inside the pump chamber (front casing) is rotated by magnetic force to transfer liquid from the suction side to the discharge side.

3. Model identification code

MX – 400 C V 5 E
(1) (2) (3) (4) (5)

(1) Pump bore and motor output code

Code	Pump bore (Suc. × Disch.)	Motor output
250	25A × 25A	0.37kW
251	25A × 25A	0.75kW
400	40A × 40A	0.37kW
401	40A × 40A	0.75kW
402, 402H	50A × 40A	1.5kW
403, 403H	50A × 40A	2.2kW

Note) Motor is two pole, three phase.

(2) Rubbing parts material

C : Carbon bearing × Alumina ceramic spindle

R : Filler charged fluoroplastics bearing × Alumina ceramic spindle

A : Alumina ceramic bearing × Alumina ceramic spindle (available for MX-250 to 401)

(3) O ring material

V : FKM

E : EPDM

A : Aflas®

(4) Impeller code

5 : 50Hz

6 : 60Hz

(5) Kind of motor

E : with IEC motor

4. Specification

50/60Hz

Model	Bore Suc. × Disch.	S.G. limit	Max. head (m)	Standard Specification (l/min, -m)	Max. Discharge capacity (l/min)	Motor output
MX-250	25 × 25	1.0	15.5	50 – 14/13.5	150	0.37kW
MX-251	25 × 25	1.0	22	80 – 19	150	0.75kW
MX-400	40 × 40	1.2	12.5/11.5	100 – 10.5/10	280	0.37kW
MX-401	40 × 40	1.2	17.5/17	150 – 14.5	320	0.75kW
MX-402	50 × 40	1.2	26/23	200 – 20	450	1.5kW
MX-402H	50 × 40	1.0	31	100 – 30	160	1.5kW
MX-403	50 × 40	1.2	30	250 – 23	500	2.2kW
MX-403H	50 × 40	1.0	35.5/37	100 – 35	300/250	2.2kW

Mass of pump (with motor)

MX-250, 400	MX-251, 401	MX-402, 402H	MX-403, 403H

5. Dimension

Model	W	H	L	a	b	c	d	e	f	g	i
MX-250	160	247.5		130	65	130	115	132.5	82.5	155.5	12
MX-251	160	247.5		130	65	130	115	132.5	82.5	163.5	12
MX-400	140	219		110	54	98	95	124	81	144	12
MX-401	160	249		130	72	130	115	134	97	178	12
MX-402(H), 403(H)	260	274		208	80	200	120	154	83	151	14×36

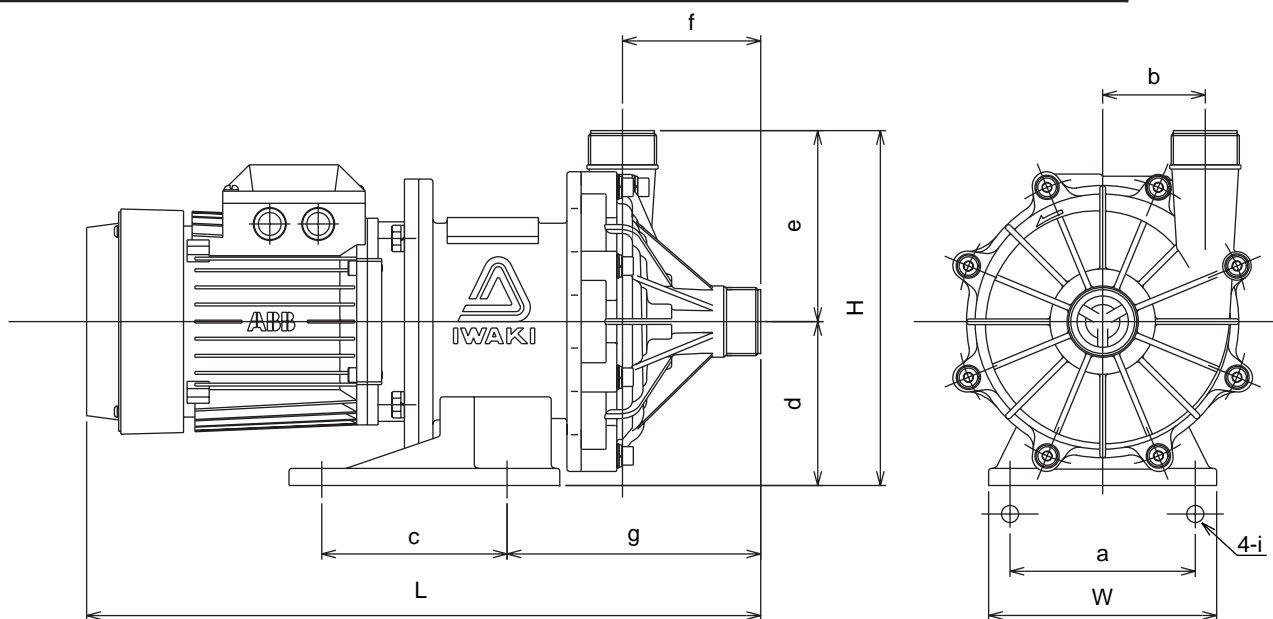

6. Name of parts and construction

(1) MX-250, 251 & 401

No.	Name	Q'ty	MX-250		MX-251		MX-401	
			Material	Remarks	Material	Remarks	Material	Remarks
1	Front casing	1	GFRPP		GFRPP		GFRPP	
2	Rear casing	1	GFRPP		GFRPP		GFRPP	
3	Impeller	1	GFRPP		GFRPP		GFRPP	
5	Drive magnet unit	1	Ferrite mag. + aluminum alloy		Ferrite mag. + FDC450		Ferrite mag. + FDC450	
8	Magnet capsule	1	Ferrite mag. + polypropylene		Ferrite mag. + polypropylene		Ferrite mag. + polypropylene	
9	Hex. head screw	2	Steel	M8 × 10	Steel	M8 × 10	Steel	M8 × 10
10	Hex. head bolt	4	Stainless steel	M8 × 20, with SW	Stainless steel	M10 × 25, with SW	Stainless steel	M10 × 25 with SW
11	Hex. head bolt	6	Stainless steel	M8 × 35, with PW, SW	Stainless steel	M8 × 35, with PW, SW	Stainless steel	M8 × 40, with PW, SW
12	Hex. head bolt	2	Stainless steel	M8 × 50, with PW, SW	Stainless steel	M8 × 50, with PW, SW	Stainless steel	M8 × 50, with PW, SW
15	Motor	1						
16	Base	1	GFRPP		GFRPP		GFRPP	
17	Adapter	1	FC 200		FC 200		FC 200	

No.	Name	Q'ty	Material			MX-250, 251	MX-401
			CV	RV	AV	Remarks	Remarks
18	Liner ring	1	Alumina ceramic 99%				
19	Rear thrust	1	CFRP				
20	Spindle	1	Alumina ceramic 99.5%				
21	Bearing	1	Carbon	Filler charged fluororesin	Alumina ceramic		
22	Mouth ring	1	Filler charged fluororesin				
23	O ring	1	FKM			JIS B 2401 G165	JIS B 2401 G165
27	Hex. head bolt	4	Steel			M8 × 20, with PW, SW	M8 × 20, with PW, SW

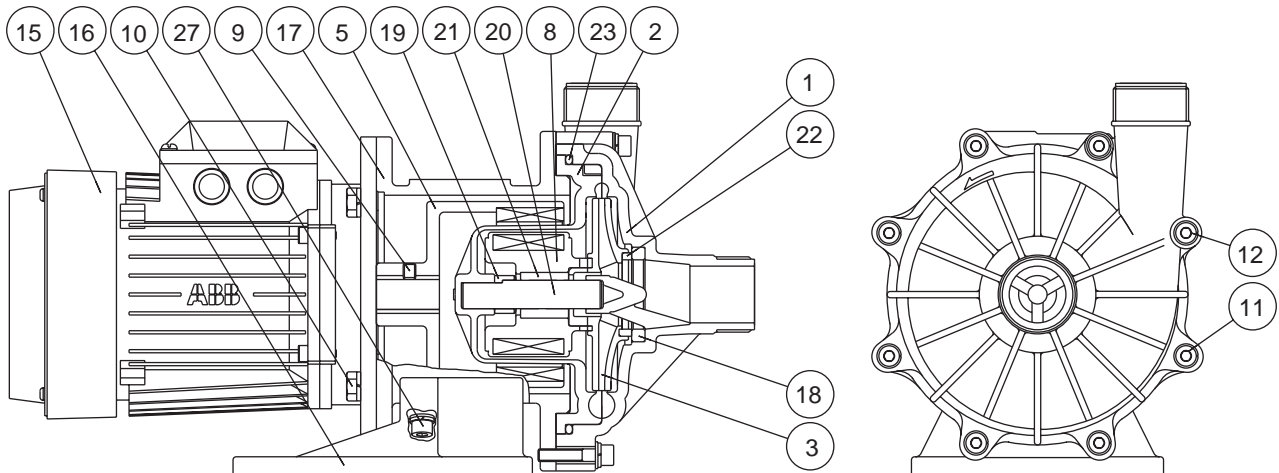

(2) MX-400

No.	Name	Q'ty	Material	Remarks	No.	Name	Q'ty	Material			Remarks
								CV	RV	AV	
1	Front casing	1	GFRPP		18	Liner ring	1	Alumina ceramic 99%			
2	Rear casing	1	GFRPP		19	Rear thrust	1	CFRPPS			
3	Impeller	1	GFRPP		20	Spindle	1	Alumina ceramic 99.5%			
5	Drive magnet unit	1	Ferrite magnet + aluminum alloy		21	Bearing	1	Carbon	Filler charged fluororesin	Alumina ceramic 99%	
8	Magnet capsule	1	Ferrite magnet + polypropylene								22
9	Hex. head screw	2	Steel	M8 × 10	23	O ring	1	FKM			JIS B 2401 G135
10	Hex. head bolt	4	Stainless steel	M8 × 20, with SW	27	Hex. head bolt	4	Steel			M8 × 20, with PW, SW
11	Hex. head bolt	6	Stainless steel	M8 × 30, with PW, SW							
12	Hex. head bolt	2	Stainless steel	M8 × 40, with PW, SW							
15	Motor	1									
16	Base	1	GFRPP								
17	Adapter	1	FC 200								

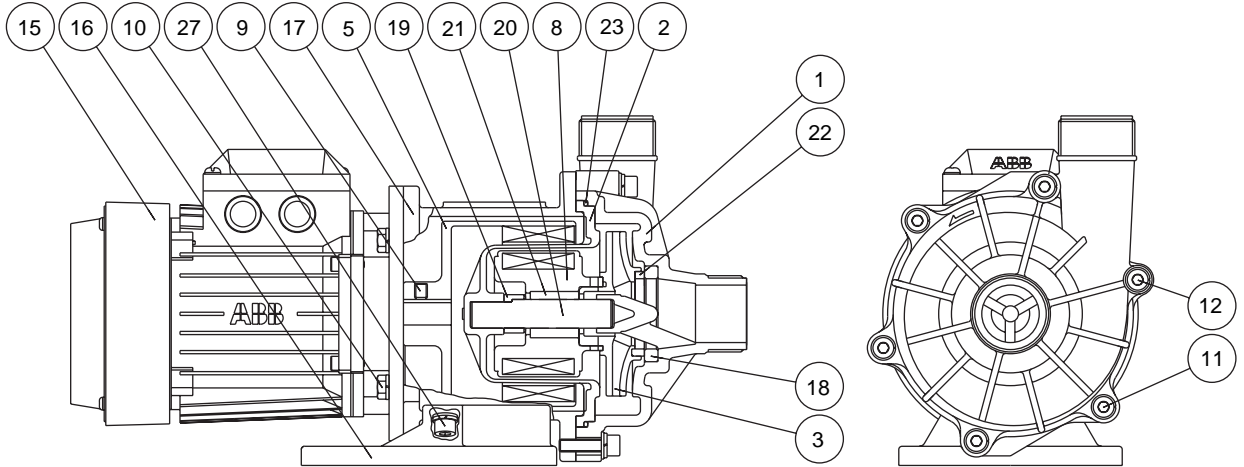

(3) MX-402(H)/403(H)

No.	Name	Q'ty	Material	Remarks	No.	Name	Q'ty	Material		Remarks
								CV	RV	
1	Front casing	1	GFRPP		18	Liner ring	1	Alumina ceramic 96%		
2	Rear casing	1	GFRPP		19	Rear thrust	1	CFRPEEK		
3	Impeller	1	GFRPP		20	Spindle	1	Alumina ceramic 99.5%		
4	Drive magnet unit	1	Rare earth magnet + FCD 450		21	Bearing	1	Carbon	Filler charged fluoro-resin	
8	Magnet capsule	1	Rare earth magnet + polypropylene							
9	Hex. head screw	2	Steel	M8 × 10	22	Mouth ring	1	Filler charged fluoro-resin		
10	Hex. bolt	4	Stainless steel	M10 × 30, with SW	23	O ring	1	FKM		JIS B 2401 G195
11	Hex. head bolt	7	Stainless steel	M10 × 45 with PW, SW	26	Hex. bolt	4	Steel		M8 × 20 with PW, SW
12	Hex. head bolt	1	Stainless steel	M10 × 60 with PW, SW	27	Lock pin	2	GFRPPS		
15	Motor	1								
16	Base	1	GFRPP							
17	Adapter	1	FC200							

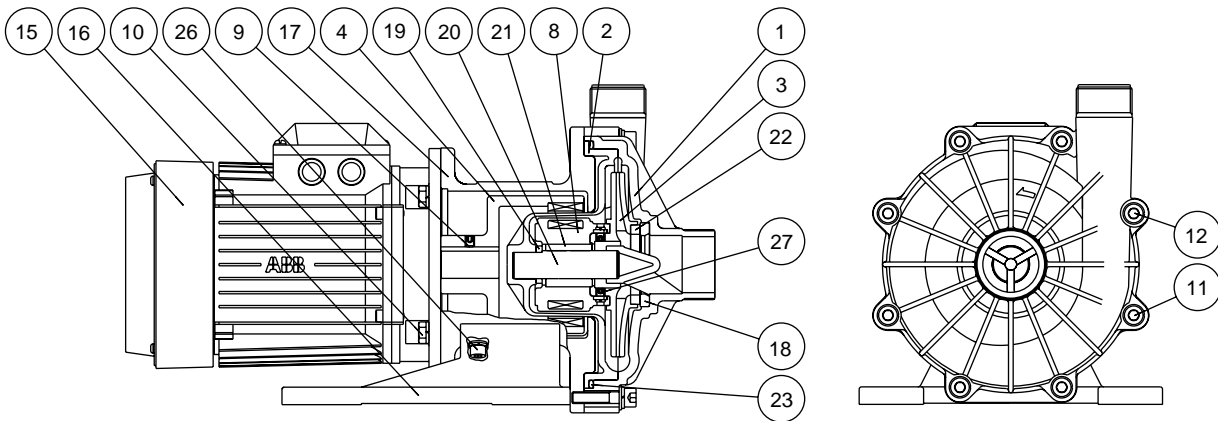

7. Main parts and label

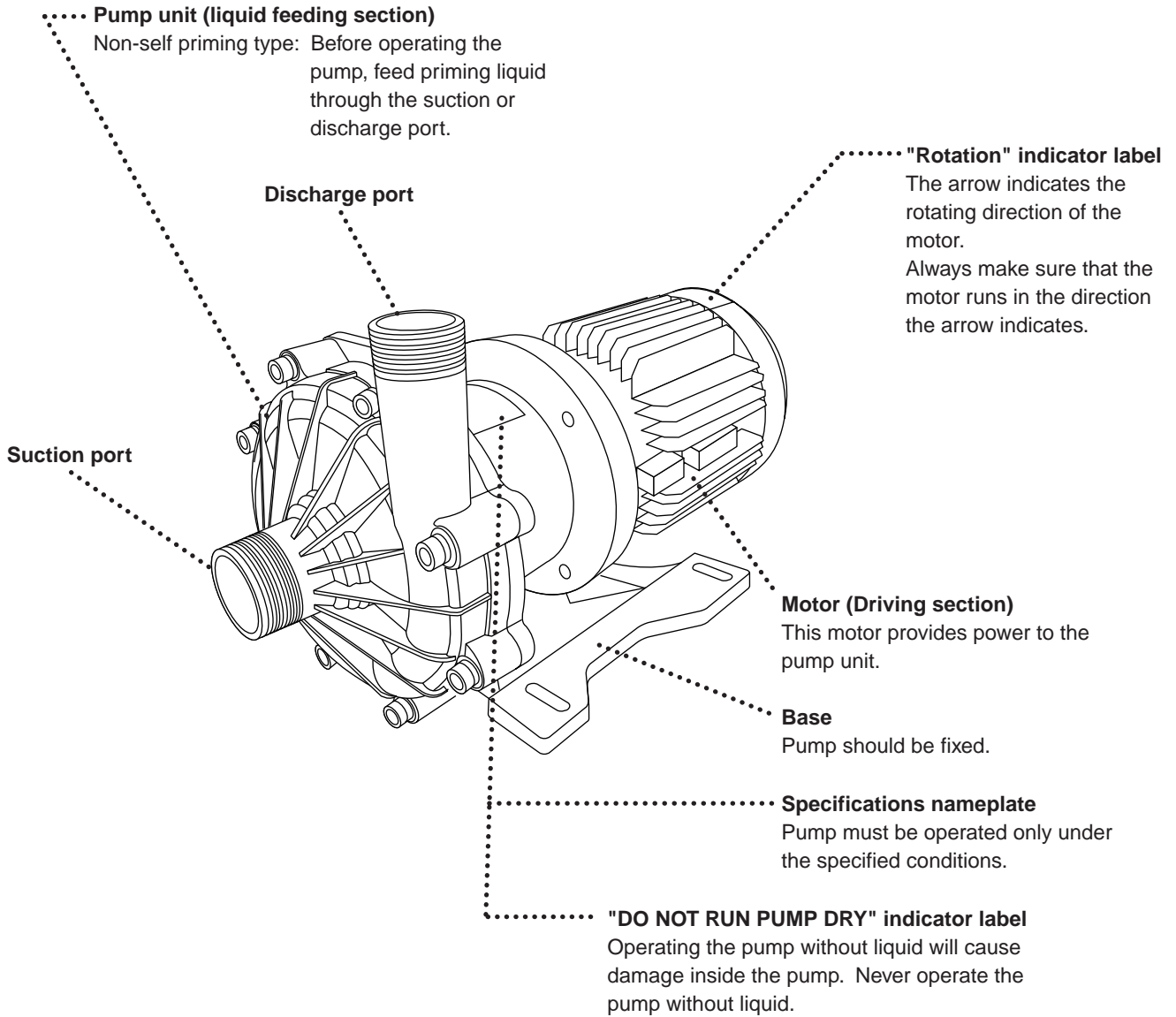

CAUTION

When cleaning the pump, be careful not to wipe the labels or the pump body with solvent.

Installation

<i>1. Before use</i>	15
<i>2. Installation</i>	17
<i>3. Piping</i>	19
<i>4. Wiring</i>	22

1. Before use

Caution

Do not run pump dry

When the pump is operated for the first time after it was installed or after it was disassembled and repaired, fill the pump chamber with the liquid to be pumped. If pump runs dry without any liquid, rubbing parts of pump are seized. The rubbing parts of MX pump are lubricated and cooled by the pumped liquid. Do not run pump dry or with suction side valve fully closed. Otherwise, pump is damaged. If the pump runs dry by mistake, switch off the power and leave it for more than one hour to cool it down slowly. IWAKI dry run protector DR model is recommended to protect pump from dry running.

Keep pump away from fire

To prevent fire and explosions, do not place dangerous or inflammable substances near to pump.

No remodeling

Do not remodel the pump. Otherwise you may be injured or electrically shocked.

1. Precautions on handling

1) Precautions when pump is started or stopped

To avoid water hammer phenomenon, pay attention to the followings when pump is started or stopped. Especially, pay special attention in case the discharge piping is long.

a. When pump is started

After priming is done, do not fail to fully close the discharge valve before the power is switched on to start pump. After the pump is started, gradually open the discharge valve to get to desired duty point.

b. When pump is stopped

Gradually close the discharge valve and switch off the power to stop pump after the valve was completely closed.

Never close the discharge line suddenly with solenoid valve or like. Sudden close of discharge line causes water hammer resulting in pump damage.

2) Do not install or store pump at the following places.

- Place where temperature falls below 0 deg. C.
- Place where exist corrosive gas or explosive gas.
- Place where water is splashed (except the pump equipped with weather-proof motor)
- Place where ambient temperature exceeds 40 deg. C.
- Humid place (Allowable humidity : 35 to 85%RH)
- Place influenced by powder, fire, earthquake and external shock.

3) Prime pump

The pump is not self-priming. Before the pump is started, prime the pump with pumped liquid. Dry running causes the seizure and quick wear of parts.

4) Pump allowable pressure

Pump allowable pressure is shown below. Pay attention so that the discharge pressure does not exceed the allowable pressure.

Model	MX-250	MX-251	MX-400	MX-401	MX-402, 403	MX-402H, 403H
Max. allowable pressure (MPa)	0.25	0.33	0.22	0.28	0.43	0.5

5) Liquids to be transferred

a. Liquid containing slurry

Slurry can not be handled but type AA (with alumina ceramic bearing) can handle slurry liquid of which the concentration up to 5%, slurry size of 50 micron m or below and hardness up to 80Hs. Contact IWAKI if you wish to handle slurry liquid.

b. Performance influenced by specific gravity and viscosity of liquid

Liquid which is heavier or more viscous than water influences the shaft power, discharge capacity and head. The pump you purchased is made according to the specifications you gave us when ordered. If you wish to change the conditions, please contact us.

c. Alumina ceramic bearing (types AV, AE, AA) may be worn in a short time depending on the characteristics of liquid (low viscosity or so). Please ask us if you have any question.

d. Influence by temperature

Pump performance is not influenced by the change of liquid temperature but the liquid changes its viscosity, vapor pressure and chemical corrosivity according to the change of temperature. Pay attention to the change of characteristics of handled liquid.

Temperature of liquid to be handled : 0 – 80 deg. C (for water)
Permissible ambient temperature : 0 – 40 deg. C
Permissible humidity : 35 – 85% RH

Refer to chemical resistant table for permissible temperature for specific chemical liquids.

6) Intermittent operation

Frequent repeat of pump stop and run may hasten pump damage. Keep the start/stop frequency within six times an hour.

7) Disconnection of magnet coupling

If the magnet coupling is disconnected, stop pump within a minute. If the pump runs with the magnet coupling being disconnected, the power of coupling will be decreased.

8) Use of pump in the range of bell-shaped pump performance curve

For the pump which shows bell-shaped performance curve in a small capacity range (Refer to standard performance curve of the pump), if this pump is used at the section of the curve that ascends, the pump may operate unstable and make vibration or noise. To avoid such a surging operation, pay attention to the followings.

- 1) Arrange the discharge piping so that air pocket can not be generated.
- 2) Install the valve near to the pump discharge port to adjust discharge capacity.

2. Installation

Warning

Switch off power

When the works are done, switch off the power. Take care other person not to switch on the power when the works are being done. In a noisy or poor visibility environment, display a sign near to the power supply switch to notify that someone is “Working” on the pump.

Do not hold plastics made parts when transferring pump

To transfer the pump, do not hold plastics made parts such as casing, flange or base. Otherwise, plastics parts may be broken and pump may fall resulting in personal injury. The weight of pump is approx. 30 kg max. Put the pump and motor horizontally with the base downward.

Electrical works

Electrical works should be done by qualified person. Otherwise personal injury or products damage may happen.

● Example of piping

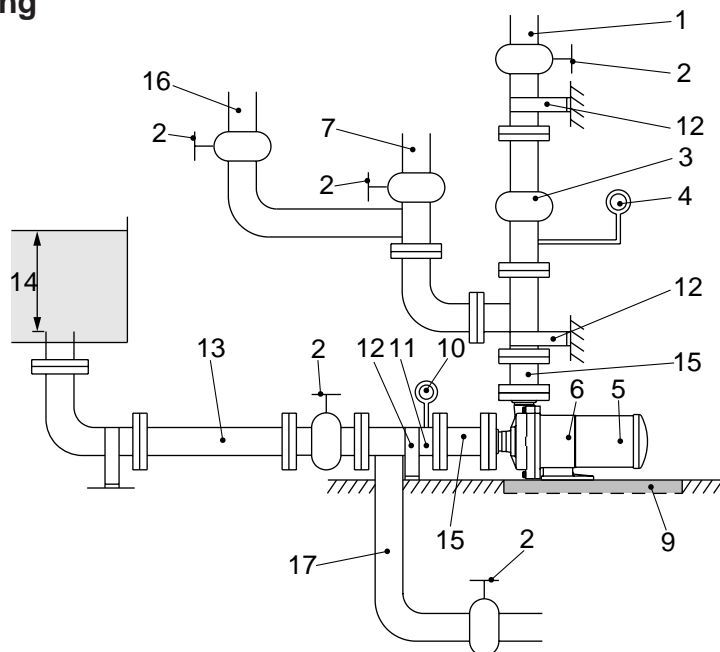

- | | |
|---|---|
| (1) Discharge pipe (Support the pipe to keep the pump free of piping load.) | (11) Suction pipe (pipe diameter: D)
(The horizontal section should be as short as possible and there should be an ascending gradient of 1/100 toward the pump.) |
| (2) Valve | (12) Pipe support |
| (3) Check valve | (13) Suction pipe (pipe diameter: D) |
| (4) Pressure gauge | (14) 2D, 500 mm or above |
| (5) Motor | (15) Expansion joint |
| (6) Pump | (16) Piping for flushing (Discharge side) |
| (7) Air vent pipe | (17) Piping for flushing (Suction side) |
| (9) Drain ditch | |
| (10) Vacuum gauge | |

1) Installation position

- Install the pump as close to the suction tank as possible and in the lowest position available (for flooded suction).
 - If the suction port of the pump is to be positioned higher than the suction tank (for suction lift), be sure to arrange for a foot valve in the priming pipe and suction pipe.
- * The lift head depends upon the liquid properties, temperature, and length of the suction piping. For details of the setup, consult Iwaki or your dealer.

2) Indoor and outdoor use

The pump can be operated either indoors or outdoors. However, safety measures should be taken so as not to expose the motor and power distribution unit to flooding or other natural hazards.

3) Installation site

Select an installation site that is flat and free of vibrations caused by nearby machines. Space sufficient for maintenance work should be provided.

● Foundation work

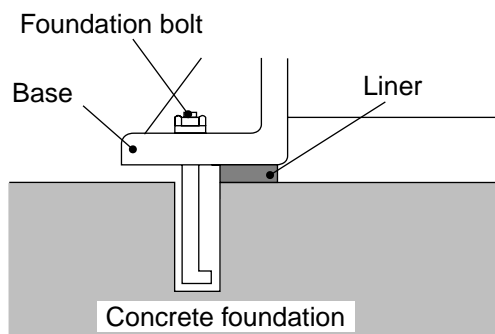

- 1) The area for anchoring the pump must be greater than the area of the base. If the anchoring area is not enough, the base may be destroyed due to a concentrated load on it.
- 2) If pump operation is to be subject to vibration (resonance with the piping, for example), provide an expansion joint between the pump and the piping. Otherwise, the piping, gauge, etc., may be damaged.

3. Piping

● Connection of pipe

Table below shows bolt size and tightening torque to connect pipes to pump flanges.

Observe the bolt size and tightening torque. (Figures on the table refer to metal flange and rubber gasket.)

Model	Bolt size	Tightening torque (N·m)
MX-250, 251, 400, 401, 402, 403	M16	20

● Load of piping and momentum of piping

The permissible stress and moment applicable to pump connection arrangement are as shown below.

The piping should be designed and worked so that stress and moment, higher than those values indicated in the table, should not be applied to the pump.

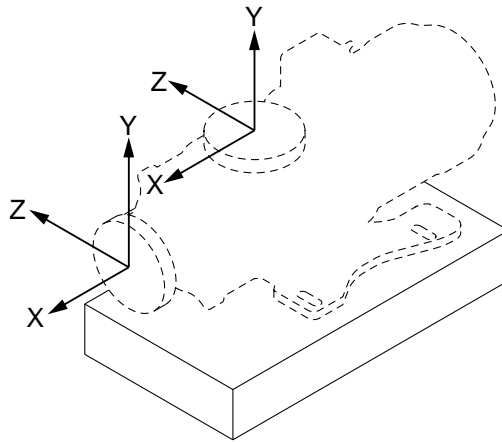

Permissible pipe load to disch. flange

Direction of load	Dia. of pipe (mm)	
	25	40
	Load	
kN		
F _x	0.10	0.15
F _y : compression	0.15	0.20
F _y : tension	0.10	0.10
F _z	0.10	0.15

Permissible pipe load to suc. flange

Direction of load	Dia. of pipe (mm)	
	25	40, 50
	Load	
kN		
F _x	0.10	0.10
F _y	0.10	0.15
F _z	0.10	0.15

Permissible pipe moments to disch. flange

Direction of load	Dia. of pipe (mm)	
	25	40
	Load	
kN·m		
M _x	0.02	0.05
M _y	0.05	0.10
M _z	0.05	0.10

Permissible pipe moments to suc. flange

Direction of load	Dia. of pipe (mm)	
	25	40, 50
	Load	
kN·m		
M _x	0.05	0.10
M _y	0.02	0.05
M _z	0.05	0.10

● Suction piping

- (1) The suction pipe should employ the flooded suction method if possible. The shortest pipe possible, with the minimum number of bends, should be used. Arrange a proper support under the suction pipe such as an expansion joint or the like so that the weight and thermal stress of the pipe are not applied to the pump.
- (2) Attach the coupling on the suction pipe carefully so as not to allow air inside the line. Air in the suction pipe may damage the system.
- (3) If suction is not good (e.g., the suction tank is a vacuum, the suction head is large, or the suction pipe is long), the condition $NPSHa > NPSHr + 0.5 \text{ m}$ should be established. For the $NPSHr$ level, refer to the standard performance curve.
- (4) When using an elbow pipe on the suction side, install a straight pipe with a length of at least 500 mm or 8 times the suction port diameter before the pump suction port. Provide the largest radius possible for the R of the bend.
- (5) Do not allow any projection where air may be trapped along the suction pipe. The suction pipe should have an ascending gradient of 1/100 toward the pump.

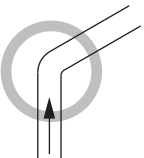
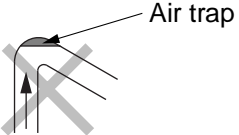
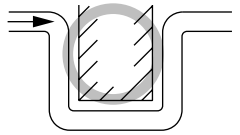
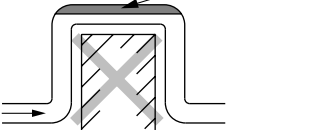
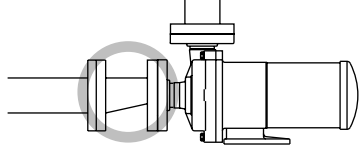
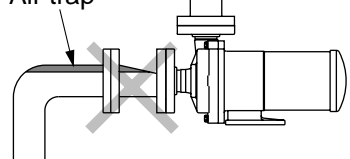
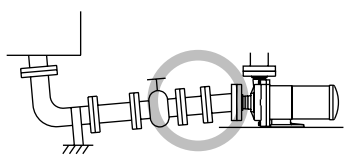
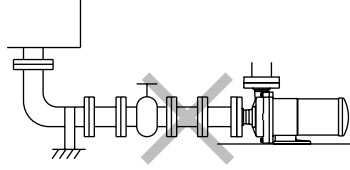
Good conditions		Unacceptable conditions	
○ good		✗ No good	
○ good		✗ No good	
○ good		✗ No good	
○ good		✗ No good	

-
-
- (6) If the diameters of the pump suction port and the suction pipe are different, use an eccentric reducer pipe. Connect the eccentric reducer pipe such that the upper surface is level. In any case, never use a suction pipe with a diameter smaller than that of the suction port.
 - (7) It is also recommended, in the case of flooded suction, that a gate valve be installed on the suction pipe for easier overhaul inspection of the pump. Keep the gate valve fully open during ordinary pump operation; it is required to be closed only during an overhaul inspection.
 - (8) When circulating a dangerous liquid, arrange the flushing pipes so that internal cleaning is possible when disassembling the pump.
 - (9) The diameter of the suction pipe must be larger than that of the pump suction port.

Note: The items below (10), (11), and (12) above are applied to the suction lift method.

- (10) The end of the suction pipe should be located 500 mm or more below the surface of the liquid.
- (11) A screen should be provided at the inlet in the suction tank to prevent the entry of foreign matter into the suction pipe. The end of the suction pipe should be 1~1.5 D (D: diameter of suction pipe) or more away from the bottom of the suction tank. Note that the entry of foreign matter may cause the pump to malfunction.
- (12) In the case of the suction lift method, install a foot valve on the suction pipe.

● Discharge piping

- (1) Use a support so that the weight of the pipe is not applied to the pump as load.
- (2) If a method other than flooded suction is employed, install a priming pipe.
- (3) If the pipe is too long the piping resistance may increase, hampering the pump's performance. The diameter of the pipe should be determined by calculating the piping resistance.
- (4) A check valve should be installed if any one of the following conditions is present. When selecting the check valve, consider the check valve pressure limit (including the influence of water hammer or back flow onto the pump).
 - ① The discharge piping is very long
 - ② The discharge lift exceeds 15 m
 - ③ The end of the discharge pipe is 9 m higher than the surface of the suction tank
 - ④ Several pumps are connected parallel to one another on the same piping

-
-
- (5) It is recommended that a valve be installed on the discharge pipe for the adjustment of discharge volume and for the prevention of overload onto the motor. When installing both a check valve and a valve, the check valve should be positioned between the pump and the valve.
 - (6) Do not fail to install a pressure gauge on the discharge piping.
 - (7) Install an air vent valve if the discharge pipe is very long horizontally.
 - (8) Install a drain valve for the drainage of liquid if there is a chance that the liquid in the discharge pipe might freeze.

4. Wiring

Electrical connections

ATTENTION

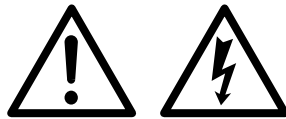

The electrical connection should be carried out by an authorized electrician in accordance with local regulations. We are not responsible for any accident which is caused by non observance of this instruction. Consult us or distributor when necessary.

- (1) Use an electromagnetic switch that conforms with the specifications (voltage, capacity, etc.) of the pump motor.
- (2) If using the pump outdoors, waterproof the wiring to protect the switches from rainwater.
- (3) Electromagnetic switch and push button switch should be firmly installed at the place reasonably distant from the pump.

Operation

<i>1. Precautions on operation</i>	<i>24</i>
<i>2. Preparation for operation</i>	<i>25</i>
<i>3. Operation</i>	<i>26</i>

1. Precautions on operation

Caution

- Never operate the pump dry or with the suction-side valve closed. Otherwise, the pump will be damaged.
- Check the direction of pump rotation. (Clockwise rotation is correct seen from motor fan.) If pump continues to run in reverse rotation, it may be damaged.
- In the event of cavitation, stop the pump within a minute.
In addition, do not continue pump operation with the air mixed into the suction side.
- If the magnet coupling disconnects, stop the pump within a minute. The power of the magnet coupling is reduced if operation is continued with the coupling disconnected.
- The temperature fluctuation should not exceed 80 °C through the starting, stopping, and operating the pump
- Before starting operation, close the discharge valve fully to prevent water hammer action upon start-up.
- Note that pump operation with the discharge valve closed fully over a long time will raise the temperature of the liquid inside the pump and finally damage the pump.
- In the event of a service power failure, turn off the power switch immediately and close the discharge valve.
- Make sure that the pressure beyond the specified one is not applied to the pump.
See page 16 for max. allowable pressure.
- Maximum pump surface temperature
The max. pump surface temperature of each model is shown in the table. Arrange protective measures in accordance with the temperature levels.



Prohibited



Caution



Caution



Model	Liquid temp (deg. C)	Maximum surface temperature when ambient temperature is at 40 deg. C (deg. C)
MX-250, 251, 400, 401, 402(H), 403(H)	80	80

- Sound generated by pump
The level of sound generated by each type of pump is shown in the table. Arrange a muffling measures in accordance with the sound level.



Model	MX-250, 400	MX-251, 401	MX-402(H), 403(H)
Sound Level	70 dB	75 dB	80 dB

2. Preparation for operation

Preparations should be made, as described below, in the case of initial operation after installation and in the case of restarting of operation after a long period of inactivity.

- (1) Thoroughly clean the inside of the pump and pipe. Then, supply liquid.
- (2) Tighten the flange connecting bolts and the installation bolts on the base.
- (3) After priming the pump, close the discharge valve fully.
Also, make sure the air-vent valve and flushing piping valve are closed.
- (4) Run the motor instantaneously to check for correct direction of motor rotation. The motor should run in the direction indicated with the arrow on the pump. If the direction is reversed, exchange any two wires of the three-phase power wires.

3. Operation

Operate the pump by following the steps given below.

No	Operation Step	Procedure
1	<ul style="list-style-type: none"> Close or open the valve. 	<ul style="list-style-type: none"> Suction valve-Fully opened Discharge valve-Fully opened
2	<ul style="list-style-type: none"> Prime the pump 	<ul style="list-style-type: none"> Confirm pump is filled with liquid. If pump is not filled with liquid, fill it in accordance with steps [5] and [6] of 'Start-up preparation'. After priming completely, close the discharge valve fully.
3	<ul style="list-style-type: none"> Check the motor for correct rotating direction. Switch on the power and then immediately switch off the power (within a second) 	<ul style="list-style-type: none"> Supply power immediately to run the pump only when checking the rotating direction of the pump. (Correct direction of pump operation is indicated with arrow on the pump. Check the direction of motor fan by looking at the fan through the fan cover.) Observe carefully to see if the motor fan slowly and smoothly stops rotating when the power switch is turned off. <p>Note: If the motor fan does not stop smoothly, the pump may be locked inside. In this case, inspect the inside of pump.</p>
4	<ul style="list-style-type: none"> Turn on the power and start the pump. Then, adjust the discharge pressure and discharge volume. <p>Following discharge volumes should be kept during pump operation. MX-250, 251, 400, 401 : 10L/min. or more MX-402(H), 403(H) : 20L/min. or more</p> <ul style="list-style-type: none"> In case of automatic drive, too, close discharge valve before start-up and open valve slowly within one minute. <p>⚠ Caution Do not run pump longer than 1 minute with a fully closed discharge valve.</p>	<ul style="list-style-type: none"> Within 1 minute, open the discharge valve gradually and adjust the discharge pressure while checking the reading of the pressure gauge on the discharge side. (Otherwise, adjust the flow rate while checking the reading of the flowrate meter.) <p>⚠ Caution Open valve carefully while paying attention to amperage meter, to prevent motor from being overloaded from excessive opening of valve.</p>
5	<p>Points to be observed during operation. If pump enters continuous operation mode, check flow meter and confirm that pump operation is as per specifications.</p>	<ul style="list-style-type: none"> If flow meter is not available, check the values of discharge pressure, suction pressure, and electric current with reference to piping resistance.

⚠ If any trouble happened, switch off power at once and settle the cause referring to the item of Troubleshooting.

Stop the pump by following step.

	Check/Operation Step	Procedure
1	<ul style="list-style-type: none">• Close discharge valve gradually.	<ul style="list-style-type: none">• Do not cause sudden closure with solenoid valve, etc., otherwise pump may be damaged by water hammer action which is likely in case of long discharge piping.
2	<ul style="list-style-type: none">• Turn off the power and stop pump operation.	<ul style="list-style-type: none">• Observe carefully whether the motor fan slowly and smoothly stops rotating. If not, check inside of pump.
3	<p>Points to be observed when stopping pump</p> <ul style="list-style-type: none">• If the pump operation is stopped during cold weather, liquid in pump may freeze and damage pump. When circulating a dangerous liquid, carry out internal cleaning by using flushing piping. Then drain the liquid fully.• Be sure to remove all liquid after stopping pump. In case of short-term suspension of operation, which does not allow for removal of liquid, use band heater, etc., to prevent liquid inside from freezing.• In event of power failure, turn off power switch and close discharge valve.	

Maintenance

<i>1. Troubleshooting</i>	<i>29</i>
<i>2. Maintenance and inspection</i>	<i>32</i>
<i>3. Spare parts</i>	<i>35</i>
<i>4. Disassembling and assembling.....</i>	<i>36</i>

1. Troubleshooting

In the case of trouble, turn off the power supply immediately and refer to this table.

Problem	Symptom on pump		Cause	Inspection and Measures
	With Discharge Valve Closed	With Discharge Valve Opened		
Liquid is not lifted.		Pressure gauge and vacuum gauge indicate 'zero'.	<ul style="list-style-type: none"> ● Not enough priming water ● Dry running. 	<ul style="list-style-type: none"> ○ Stop pump, feed sufficient priming water, and restart pump.
	Water goes down at once when priming is carried out.		<ul style="list-style-type: none"> ● Foreign matter is clogging foot valve. 	<ul style="list-style-type: none"> ○ Clean foot valve. ○ Check whether seat is clogged with foreign matter.
	Pressure is reduced if discharge valve is opened after start-up step.	Points of pressure gauge and vacuum gauge swing but return to zero at once.	<ul style="list-style-type: none"> ● Air enters through suction pipe or gasket section. 	<ul style="list-style-type: none"> ○ Check again whether connecting flange in suction piping is sealed airtight. ○ Check whether suction liquid level is abnormally lowered.
	Pointer of pressure gauge never rises.		<ul style="list-style-type: none"> ● Magnet coupling has disconnected. 	<ul style="list-style-type: none"> ○ Measure electric current level to check for overload condition. ○ Check for foreign matter between impeller and casing. ○ Check whether the voltage level is normal.
Discharge volume is small.		Pointer of vacuum gauge indicates a high value.	<ul style="list-style-type: none"> ● Strainer is clogged with foreign matter and liquid passage is blocked. 	<ul style="list-style-type: none"> ○ Eliminate the foreign matter in strainer.

Problem	Symptom on pump		Cause	Inspection and Measures
	With Discharge Valve Closed	With Discharge Valve Opened		
Discharge volume is small.	Pointers of pressure gauge and vacuum gauge indicate normal values.	Pointer of vacuum gauge indicates extraordinarily high value.	● Air is trapped in suction pipe.	○ Inspect setup condition of suction pipe and modify it if necessary.
			● Inlet section of impeller unit is clogged with foreign matter.	○ Eliminate foreign matter.
		Pointers of pressure gauge and vacuum gauge swing.	● Air enters through suction pipe or gasket section.	○ Check connecting section of suction pipe and tighten it if necessary..
			● Discharge side of pump is clogged with foreign matter.	○ Eliminate foreign matter in the pump. ○ Eliminate foreign matter or scale inside pipe..
		Pointer of vacuum gauge indicates a high value while that of pressure gauge indicates normal value.	● There is an air trap or resistance in suction pipe.	○ Check whether there is protruding section in suction pipe and take necessary measures.
		Pointer of pressure gauge indicates high value while that of vacuum gauge indicates normal value.	● There is portion in discharge pipe that causes resistance, or actual head and loss of head are too high.	○ Check actual head and piping loss of discharge pipe and take necessary measures.
	Pointer of pressure gauge indicates low value and that of vacuum gauge indicates extraordinarily low value.	Pointers of pressure gauge and vacuum gauge indicate low values.	● Rotation direction is reversed.	○ Exchange wires.

Problem	Symptom on pump		Cause	Inspection and Measures
	With Discharge Valve Closed	With Discharge Valve Opened		
Motor is overheated.			<ul style="list-style-type: none"> ● Voltage is lowered. ● Overload. 	<ul style="list-style-type: none"> ○ Check whether the voltage and frequency levels are adequate. ○ Check whether the specific gravity and viscosity of liquid are adequate. ○ Improve air ventilation.
Discharge volume is suddenly lowered.		Pointer of vacuum gauge indicates high value.	<ul style="list-style-type: none"> ● Strainer is clogged with foreign matter. 	<ul style="list-style-type: none"> ○ Eliminate foreign matter.
Pump vibrates.			<ul style="list-style-type: none"> ● Foundation is defective. ● Anchor bolt is loose. ● Suction pipe is closed. Cavitation is caused. ● Wear or melting of pump bearing. ● Magnet capsule or spindle is damaged. ● Dynamic balance of drive magnet assembly fluctuates. ● Impeller and/or magnet capsule is in contact with fixing section. ● Wear of motor bearing. 	<ul style="list-style-type: none"> ○ Reinstall. ○ Retighten bolts. ○ Clean, and eliminate cause of cavitation. ○ Replace. ○ Replace. ○ Eliminate cause or replace. ○ Replace. ○ Replace bearing or motor.

2. Maintenance and inspection

Warning

Wear protectors

Hazardous liquids such as chemical liquids may harm your eyes or skin if you touch them directly or they are splashed. When you do the works, wear protectors (mask, goggles, gloves etc.).

Turn off power

To avoid electrical shock, switch off the power to stop pump and equipment when works are done.

● Daily inspection

- (1) Check to be sure there is no liquid leakage in the pump before operating it. If leakage is detected, never try to operate the pump.
- (2) Check whether the pump operates smoothly, without generating any abnormal noise or vibration.
- (3) Check the level of the liquid in the suction tank and the suction pressure.
- (4) Compare the discharge pressure and electric current measured during operation with the values indicated on the motor nameplate for the verification of normal pump load.
 - * Note that the values indicated on the pressure gauge is in proportion to the specific gravity of the liquid. The cock of the pressure gauge or vacuum gauge must be opened only when measurement is carried out. It must be closed upon the completion of each measurement. If the cock remains open during pump operation, the meter mechanism may be affected by abnormal pressure caused by water hammer action.
- (5) If a spare pump is prepared, activate it from time to time to keep it ready for use any time.
- (6) Check to be sure the discharge pressure, discharge flow rate, and motor power supply voltage do not fluctuate during pump operation. If considerable fluctuation of the respective values occurs, refer to "Troubleshooting" for correct measures.

● Periodic inspection

To ensure efficient and smooth operation of the pump, carry out periodic inspections by following the procedures described below. When the pump is disassemble, handle the rubbing parts and plastics parts with care not to damage them. Pay attention not to pinch your fingers because the drive magnet and magnet capsule have strong magnetic force

Inspection Timing	Part Name	Check Points	Countermeasures
Every 6 months * Inspection record should be kept.	Drive magnet unit	<ul style="list-style-type: none"> ● Are there slide-scratches? ● Is drive magnet fixed correctly? Is hex. socket set screw loose? ● Are inner perimeter of magnet and motor shaft coaxial? (Max. eccentricity: 1/10 mm) 	<ul style="list-style-type: none"> ○ Contact your dealer if abnormality is found. ○ Fix drive magnet correctly. Tighten set screw. ○ Tighten set screw correctly or replace drive magnet. (Contact your dealer if replaced.)
	Rear casing	<ul style="list-style-type: none"> ● Are there slide-scratches in bore? ● Are there cracks on liquid end part? ● Wear of rear thrust. ● Wear of spindle. ● Stains in rear casing. 	<ul style="list-style-type: none"> ○ Contact your dealer if abnormality is found. ○ Replace rear casing if abnormality is found. ○ Contact your dealer if abnormality is found. ○ Replace if wear limit comes. ○ Clean.
	Magnet capsule	<ul style="list-style-type: none"> ● Are there slide-scratches in the rear section or in the cylindrical body? ● Are there cracks in resin of rear section or in cylindrical body? ● Wear of bearing. (Measure dimensions.) ● Condition of impeller fixed to magnet capsule 	<ul style="list-style-type: none"> ○ Contact your dealer if abnormality is found. ○ Contact your dealer if abnormality is found. ○ Replace if wear limit comes. ○ Replace or contact your dealer if fixing is loose.
	Impeller	<ul style="list-style-type: none"> ● Wear of mouth ring. (Measure dimensions.) ● Are there cracks? ● Stains or clogging inside impeller. ● Dimensional change in impeller. 	<ul style="list-style-type: none"> ○ Replace if wear limit comes. ○ Replace if abnormality is found. ○ Clean ○ Replace if abnormality is found.
	Front casing	<ul style="list-style-type: none"> ● Stains in liquid contacting part. ● Are there cracks? ● Are there wear, slide-scratches, or cracks in liner ring? ● Are there expansion or cracks on O ring. ● Slide-scratches in unlikely position. 	<ul style="list-style-type: none"> ○ Clean ○ Replace if abnormality is found. ○ Contact your dealer if abnormality is found. ○ Replace O ring if it is expanded or cracked. ○ Contact your dealer if abnormality is found.
	Spindle	<ul style="list-style-type: none"> ● Are there cracks? ● Wear of rubbing parts 	<ul style="list-style-type: none"> ○ Replace if abnormality is found. ○ Replace if wear limit comes.

● Wear limit of bearing and spindle

Unit: mm

Part \ Model	MX-250, 251, 400, 401		MX-402, 402(H), 403, 403(H)	
	When shipped	Time to be replaced	When shipped	Time to be replaced
Inner diameter of bearing	18	19	24	25
Outer diameter of spindle	18	17	24	23

* If the difference between the inner diameter of the bearing (No.21 of view on page 35) and the outer diameter of the spindle (No.20 of view on page 35) exceeds 1 mm, either the bearing (as magnet capsule unit No.8 shown on view of page 35) or the spindle whichever has the greater wear should be replaced regardless of the values in the above table. In the case of AV or AE type pump (MX-250 to 401), the spindle and the bearing (as magnet capsule unit No.8) should be replaced simultaneously.

* Initial wear may appear in the sliding parts in the first stages of operation. This is not abnormal.

● Wear limit of mouth ring

Unit: mm

Model	MX-250, 251, 400, 401, 402(H), 403(H)
Thickness when shipped	8
Thickness when replaced	6

* The step between the surfaces of the mouth ring (No.22 of view on page 35) and the impeller (No.3 of view on page 35) upon shipment is 2 mm (3 mm for MX-250). The wear limit of the mouth ring is that this step is reduced to 0 mm. Replace the impeller unit with the mouth ring then.

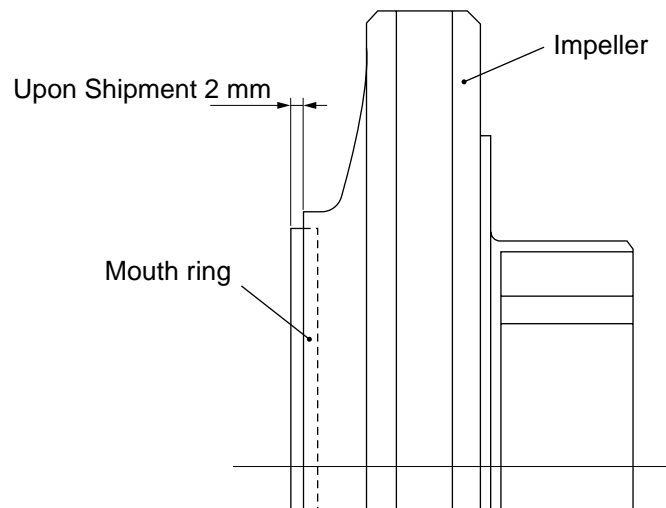

3. Consumable parts

Appropriate consumable parts are necessary to be replaced to ensure long, continuous operation of the pump. Replace the following consumable parts according to the time to be replaced shown below and according to the Notes mentioned below.

No.	Part name	Time to be replaced	Parts code							
			MX-250	MX-251	MX-400	MX-401	MX-402	MX-403	MX-402H	MX-403H
1	Front casing unit	10,000 hours	MX0109		MX0125	MX0131	MX0174		MX0188	
29	Impeller unit 50Hz		MX0111	MX0120	MX0127	MX0133	MX0176	MX0184	MX0190	MX0191
29	Impeller unit 60Hz		MX0112	MX0121	MX0128	MX0134	MX0177	MX0185	MX0185	MX0176
8	Magnet capsule unit C (Carbon)		MX0113	MX0122	MX0113	MX0122	MX0178	MX0186	MX0178	MX0186
8	Magnet capsule unit R (PTFE)		MX0114	MX0123	MX0114	MX0123	MX0179	MX0187	MX0179	MX0187
8	Magnet capsule unit A (Alumina ceramic)		MX0115	MX0124	MX0115	MX0124	—	—	—	—
23	O ring (for casing)	10,000 hours or every time when pump is disassembled.	MX0116		MX0129	MX0116	MX0180			
20	Spindle	10,000 hours	MX0118				MX0182			
19	Rear thrust		MX0119				MX0183			

Note1: Parts code of O ring is for V type (FKM).

Ask us for E type (EPDM) and A type (Aflas®).

Note2: Time to be replaced mentioned above is based on pumping clear water at ambient temperature. The time to be replaced depends on the characteristics, temperature and other condition of pumped liquid.

Note3: Bearing No. 21 (as magnet capsule unit No. 8), mouth ring No. 22 (as impeller unit No. 29) and spindle No. 20 must be replaced at the time of wear limit mentioned on page 34 regardless of the time to be replaced shown on above table.

MX-250/251/400/401

MX-402/403/402H/403H

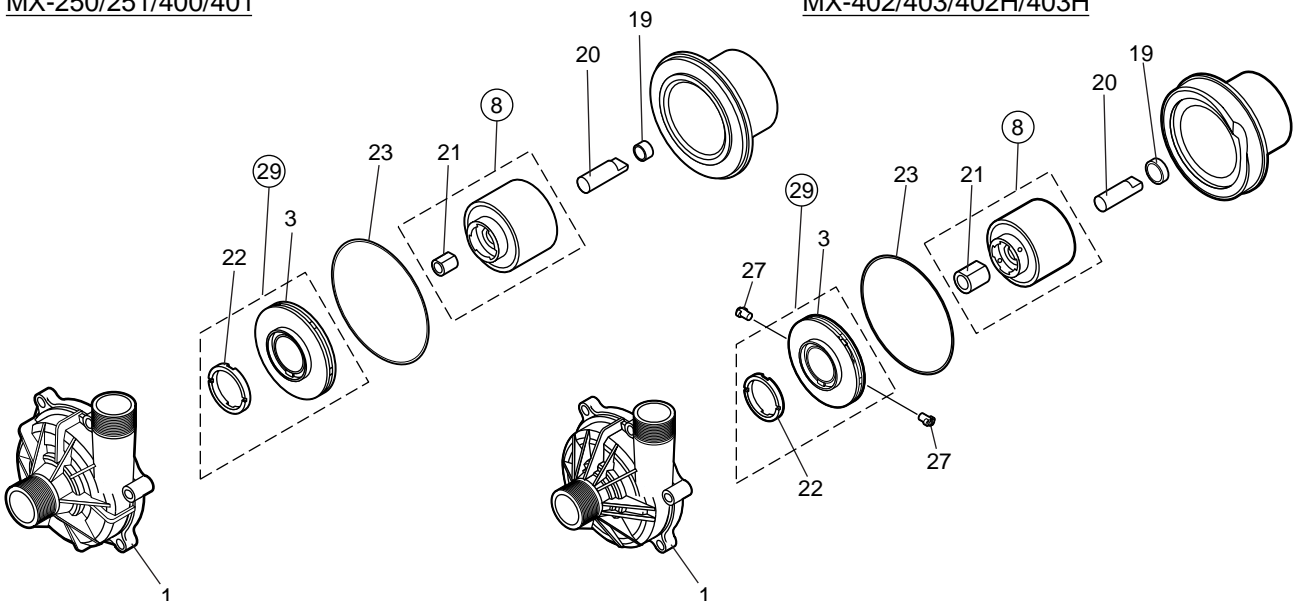

4. Disassembling and assembling

Warning

Wear protectors

Hazardous liquids such as chemical liquids may harm your eyes or skin if you touch them directly or they are splashed. When you do the works, wear protectors (mask, goggles, gloves etc.).

Turn off power

To avoid electrical shock, switch off the power to stop pump and equipment when works are done.

Precautions when disassembling and assembling pump

- * When power wires to motor are removed, mark on each wire so that the wires can be connected correctly not to rotate in reverse when they are connected again.
- * Do not disassemble the pump beyond the extent shown on this manual.
- * Fully close suction and discharge sides valves before the works are done and clean pump inside.
- * The magnet force used in the pump are strong. Pay attention for your fingers not to be pinched on disassembling and assembling of pump. Pay attention for iron pieces or powder not to be attracted by the magnets.
- * Do not put the electronic devices which dislike magnetic field near to the magnets.

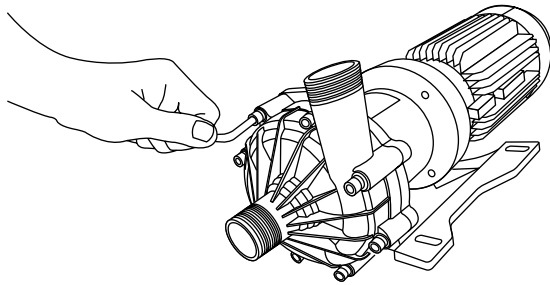

4.1 Disassembling

- 1) Remove hex. socket head bolts to remove a front casing from a motor bracket and evacuate the casing of residual liquid and clean it.

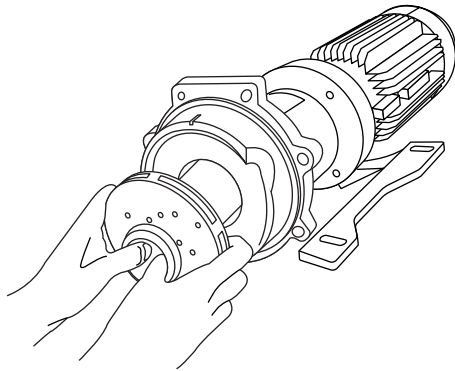

- 2) Pull out an impeller and a magnet capsule. Pay attention for your fingers not to be pinched.

- 3) When the impeller is removed from the magnet capsule, take following procedure paying attention not to scratch the parts.

- a. In case of MX-250-401

Hold the magnet capsule by hand and slightly tap the back side of impeller by plastics hammer to remove it from magnet capsule. If it is hard to be removed, do not remove them by force but put them in hot water (approx. 90 deg. C) for five minutes. Take care for your fingers not to be burnt by hot water.

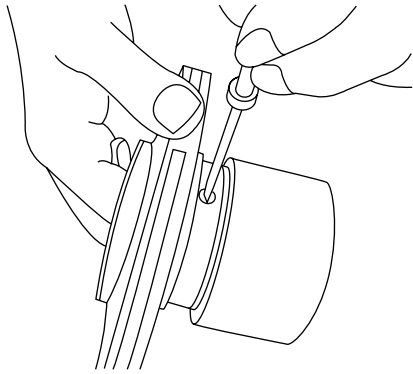

b. In case of MX-402(H) and 403(H)

Turn the lock pin counter clockwise direction by 90 degree using a minus screw driver and then push it out to inside. If it is hard to push it out, slightly tap the end of driver handle. If the screw driver can not be used because the groove of pin was crushed, turn the pin from inside of magnet capsule using hex. wrench. In this case pay attention to turn the wrench clockwise. The lock pin will be damaged if it is turned in reverse direction. After the pin was turned, push it out from outside using a bar or like.

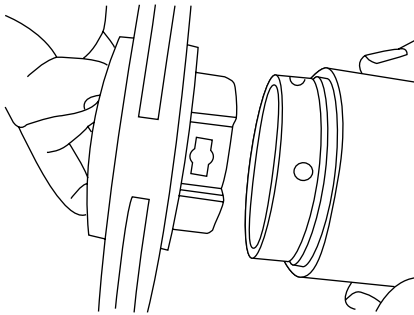
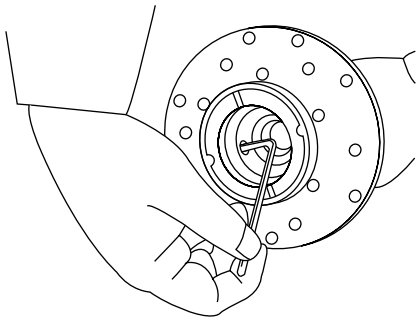

After two lock pins are removed, remove the impeller from the magnet capsule by slightly tapping the periphery of impeller with plastic hammer. If it is hard to remove, warm it with hot water (approx. 90 deg. C) for five minutes and remove it by slightly tapping it as above. Pay attention not to burn yourself.

Impeller can not be separated from magnet capsule unless lock pin is removed. The parts are broken if impeller is removed by force.

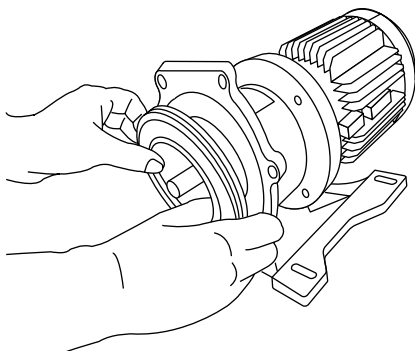

- 4) To remove a rear casing, insert a minus screw driver to the periphery of rear casing and slightly pull forward the screw driver. Pay attention not to scratch an O ring.

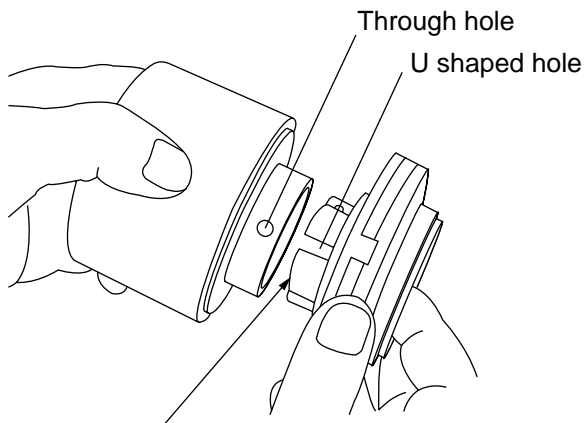

End surface of press-fit part

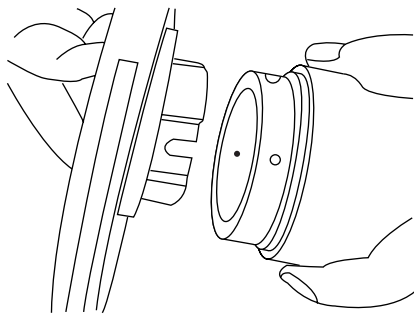
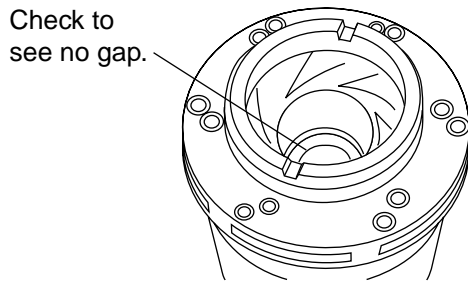

4.2 Assembling

1) Mount the impeller to the magnet capsule.

a. In case of MX-250-401.

Fit together the projected and recessed parts of magnet capsule and impeller and push the impeller to the bottom. Put a through hole of magnet capsule and U shaped hole of impeller together. If you find no gap between the end surface of impeller and bearing end surface, this means the impeller was securely press fit into the magnet capsule. If it is hard to press fit them, do not put them by force but warm the magnet capsule only by putting it in hot water (approx. 90 deg. C) for five minutes. Take care for your fingers not to be burnt by hot water.

b. In case of MX-402(H) and 403(H)

Mating part of magnet capsule has two holes of a bigger hole for lock pin (stepped hole of outside 6 mm dia. and inside 12 mm dia.) and a smaller hole (3 mm dia.) for cooling purpose. U-shape hole of impeller and smaller hole (3 mm dia.) of magnet capsule are for cooling purpose. Insert the impeller into the magnet capsule slowly by positioning the two holes together. If it is hard to insert them, warm the magnet capsule only with hot water (approx. 90 deg. C) for five minutes.

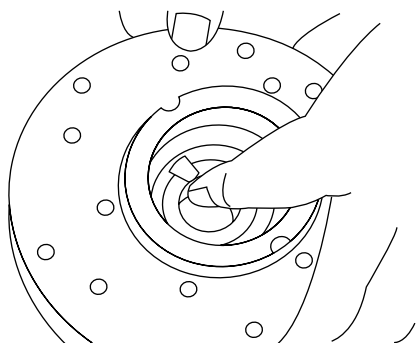

After the impeller is inserted (press-fit), insert the lock pin till the first step from inside and then, strongly holding it by finger from inside, tighten the pin by turning it clockwise by 90 degrees from outside with minus screw driver. You will feel the snap action when it is fixed securely. Mount two lock pins at symmetric position.

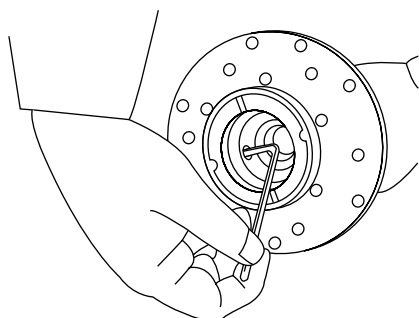
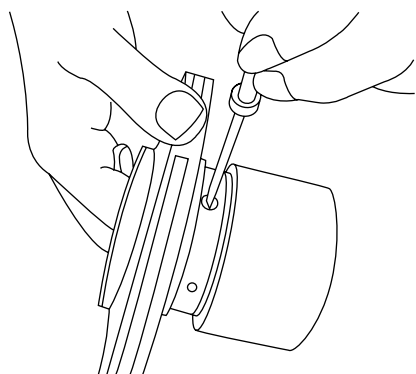

If the groove for minus screw driver is deformed and can not be used, the pin can be fixed from inside with 4mm hex. wrench. In this case pay attention to turn the wrench counter clockwise direction. The lock pin may be broken if it is turned in reverse.

- 2) Put the magnet capsule with impeller into the rear casing slowly. Check if iron pieces or other foreign matters do not adhere to the magnet capsule
- 3) Mount the rear casing with magnet capsule to the bracket.

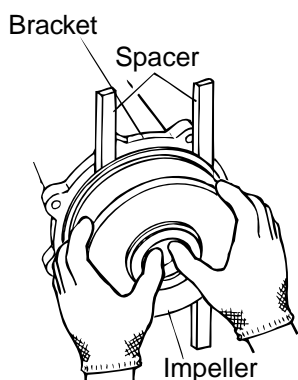

⚠ Caution

Magnet force is very strong. Apply plastics or wooden spacers between the rear casing and bracket not to pinch your fingers.

-
- 4) Put O ring to the front casing. Check to see if there is no dust or scratch on it. Pay attention for the O ring not to be forgotten to be put or not to be bitten. For the models MX-250, 251 and 401, fit together the recessed and projected portions of rear casing and front casing when the front casing is mounted to the rear casing. Two recesses on rear casing and projections on front casing are for MX-402(H) and 403(H).

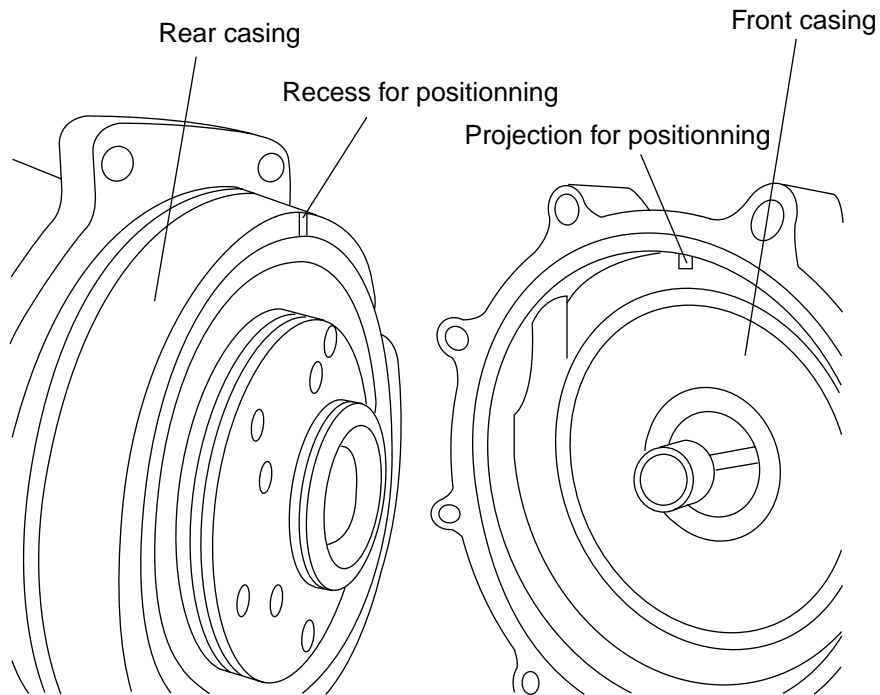

- 5) Mount the front casing to the motor bracket.

Tighten the mounting bolts diagonally and evenly. Tightening torque is shown below.

Model	Bolt tightening torque
MX-250,251, 400, 401	11.8 N·m
MX-402, 402(H), 403, 403(H)	14.7 N·m



IWAKI CO.,LTD. 6-6 Kanda-Sudacho 2-chome Chiyoda-ku Tokyo 101-8558 Japan

TEL:(81)3 3254 2935 FAX:3 3252 8892(<http://www.iwakupumps.jp>)

()Country codes

Germany	: IWAKI EUROPE GmbH	TEL : (49)2154 9254 0	FAX : 2154 1028	U.S.A.	: IWAKI WALCHEM Corporation	TEL : (1)508 429 1440	FAX : 508 429 1386
Italy	: IWAKI Italia S.R.L.	TEL : (39)02 990 3931	FAX : 02 990 42888	Australia	: IWAKI Pumps Australia Pty. Ltd.	TEL : (61)2 9899 2411	FAX : 2 9899 2421
Denmark	: IWAKI Pumper A/S	TEL : (45)48 24 2345	FAX : 48 24 2346	Singapore	: IWAKI Singapore Pte. Ltd.	TEL : (65)763 2744	FAX : 763 2372
Sweden	: IWAKI Sverige AB	TEL : (46)8 511 72900	FAX : 8 511 72922	Indonesia	: IWAKI Singapore (Indonesia Branch)	TEL : (62)21 690 6607	FAX : 21 690 6612
Finland	: IWAKI Suomi Oy	TEL : (358)9 2742714	FAX : 9 2742715	Malaysia	: IWAKIm Sdn. Bhd.	TEL : (60)3 7803 8807	FAX : 3 7803 4800
Norway	: IWAKI Norge AS	TEL : (47)66 81 16 60	FAX : 66 81 16 61	Taiwan	: IWAKI Pumps Taiwan Co., Ltd.	TEL : (886)2 8227 6900	FAX : 2 8227 6818
France	: IWAKI France S.A.	TEL : (33)1 69 63 33 70	FAX : 1 64 49 92 73	Thailand	: IWAKI (Thailand) Co.,Ltd.	TEL : (66)2 320 1303	FAX : 2 322 2477
U.K.	: IWAKI PUMPS (UK) LTD	TEL : (44)1743 231363	FAX : 1743 366507	Hong Kong	: IWAKI Pumps Co., Ltd.	TEL : (852)2 607 1168	FAX : 2 607 1000
Switzerland	: IWAKI (Schweiz) AG	TEL : (41)32 3235024	FAX : 32 3226084	China	: GFTZ IWAKI Engineering & Trading Co., Ltd.	TEL : (86)20 8435 0603	FAX : 20 8435 9181
Austria	: IWAKI (Austria) GmbH	TEL : (43)2236 33469	FAX : 2236 33469	China	: IWAKI Pumps Co., Ltd. (Beijing office)	TEL : (86)10 6442 7713	FAX : 10 6442 7712
Holland	: IWAKI Holland B.V.	TEL : (31)297 241121	FAX : 297 273902	China	: IWAKI Pumps (Shanghai) Co., Ltd.	TEL : (86)21 6272 7502	FAX : 21 6272 6929
Spain	: IWAKI Iberica Pumps,S.A.	TEL : (34)943 630030	FAX : 943 628799	Philippines	: IWAKI Chemical Pumps Philippines, Inc.	TEL : (63)2 888 0245	FAX : 2 843 3096
Belgium	: IWAKI Belgium n.v.	TEL : (32)1430 7007	FAX : 1430 7008	Korea	: IWAKI Korea Co.,Ltd.	TEL : (82)2 3474 0523	FAX : 2 3474 0221