

Systeme für Aquakultur,
Aquaristik, Labore und
zur Wasseraufbereitung

Systems for aqua culture,
sea water aquaria, labs and
water desalination and purification

Systèmes pour aquacultur,
aquariums eau de mer,
laboratoires et traitements d'eau



AquaCare GmbH & Co. KG
Am Wiesenbusch 11
D-45966 Gladbeck
Tel.: +49-2043-375758-0
Fax: +49-2043-375758-90
<http://www.aquacare.de>
e-mail: info@aquacare.de

Instruction manual of Skimmer ACF size 6.000 and more, versions „V“, „VI“, „VC“, „VCI“

lizenziert vom Forschungszentrum Jülich GmbH, Bundesrepublik Deutschland



modifications possible

Content

1.	Safety Instructions	4
1.1.	General information	4
1.2.	Indication of information	4
1.3.	Qualification of the personnel.....	4
1.4.	Dangers if safety information are not minded	4
1.5.	Safe working	4
1.6.	Safety information for the operator	4
1.7.	Safety information for maintaining and assembling personnel	4
1.8.	Arbitrary reconstruction and spare parts production	4
1.9.	Illegal operation	5
1.10.	Linked aggregates	5
2.	Transport	5
2.1.	Mechanical conditions	5
3.	Designated use	5
4.	Configuration	5
4.1.	I O diagram	6
4.2.	Basic equipment.....	7
4.3.	Options.....	8
5.	Principle of function	8
6.	Installation	8
6.1.	Setting up	8
6.2.	Assembly of the skimmer	9
6.3.	Water connections.....	9
6.4.	Electrical connection.....	10
7.	Start up the unit	10
7.1.	Filling up with water	10
7.2.	Adjusting the inlet water flow	10
7.3.	Adjusting the water level inside of the skimmer	10
7.4.	Air and ozone volumes	11
7.5.	Ozone needs of the skimmer	11
7.6.	Flushing equipment of the skimmer	11
7.7.	Features of skimmer type „C“	11
8.	Shut down the unit	11
9.	Maintain the unit	11
9.1.	Inlet pump / main pump	12
9.2.	Injector	12
9.3.	Skimmer cup / flushing nozzles	12
9.4.	Main tube	12
10.	Trouble shooting	12
10.1.	The air flow is diminishing	12
10.2.	The skimmer does not produce foam.....	12
10.3.	The skimmer produces too much and too wet foam / the skimmer foams over.....	13
10.4.	The air bubbles do not reach the basis / expanding cone.....	13
11.	Warranty	13
12.	Technical Data	14
13.	Protocol	15
14.	Appendix: switch board	17
15.	Appendix: pump	18
16.	Appendix: motor	19

17.	Appendix: ozone generator	20
18.	Appendix: ozone destructor	21

1. Safety Instructions

1.1. General information

This manual contains basic information that are important for assembly, operation, and maintenance. This should be read before mounting by the assembly operator and the responsible operator and/or qualified personnel. This instruction must be disposable the at unit at any time.

Pay attention to this safety instruction as well as to the special instructions within the other chapters. In addition local laws and safety instruction must be minded.

1.2. Indication of information



If safety information are important for life or health for persons they are marked with the relevant hazard symbol according DIN 4844-W9.



Safety information marked with this symbol can cause danger for the machine and its function if not respected.



This hints can ease the work with the machine and its maintenance.

At the machine directly marked information as rotation arrow, fluid connections and setting points should be noticed. These marks should be readable at any time.

1.3. Qualification of the personnel

The staff for operation, maintaining, inspection and assembly must be qualified for these work. Responsibility and controlling of the personnel should be directed by the operator.

1.4. Dangers if safety information are not minded

If safety information are not minded persons, environment, and the machine can be endangered. Failure of observe lead to loss of the warranty.

Failure of observe can coarse:

- Failure of important functions of the machine.

- Failure of stipulated methods for maintenance.
- Endanger of persons with electric, chemical or mechanical impacts.

1.5. Safe working

Working with the machine is only allowed if all safety information of this manual, national laws and rules for preventing accidents and internal working, operating and safety rules of the operator must be minded.

1.6. Safety information for the operator

Contact protection for rotating or moving parts should not be removed while operation.

Risks of electrical energy must be averted. Please pay attention to the local laws and information, too.

1.7. Safety information for maintaining and assembling personnel

The operator must take care that all works for assembling, inspecting and maintaining are made by authorized and qualified personnel. These persons must be informed about the machine and the works by reading the manual or otherwise.

Working at the machine is only permitted if unit is out of operation. The described procedure of putting out of operation must be redeemed. Immediately after the work safety and protection facilities must be mounted and put into function.

Before starting again all issues treated in the chapter “putting into operation” must be minded.

1.8. Arbitrary reconstruction and spare parts production

Reconstruction or modifying the unit are only proper if the manufacture agrees. Original spare parts and authorized accessories by the manufacture are made for the safety. The use of other parts can destroy the warranty demands.

1.9. Illegal operation

Safety is only guaranteed if the unit is running within the field of application described in „designated use“ in this manual. The technical limits mentioned in manual (chapter “Technical data and unit protocol”) must be redeemed.

1.10. Linked aggregates

The listed information dealing with safety and operation in manuals of linked aggregates must be redeemed, too.

2. Transport

2.1. Mechanical conditions



The unit may transported only with suitable lifting tools. Pay attention to the transport weight listed in chapter “Technical data and unit protocol”.

Do not tilt the unit more than 10% out of the horizontal position.

Before transporting the unit it must be totally empty (this does not apply to the filter bed granules).

3. Designated use

AquaCare skimmers are made only for filtering water of aquaria and aqua culture units. The treated water should have a TDS (total dissolved solids) of minimum 15.000 ppm. Other purposes are only allowed after consultation with AquaCare.

4. Configuration

The unit is completely delivered. The skimmer has to be erected and supplied with water and electricity. Please control the delivery if it is complete and not broken.

The type “C” has built in an internal circulation for treating very highly polluted waters.

The type “I” are insolated and can be used with water around zero degree Centigrade.

On request the types are equipped with an ozon-recycling device to enlarge the ozone enrichment.

4.1. I O diagram

IO diagram AquaCareFlotor		AquaCare Josefstrasse 35-37 D-45699 Herten Germany phone: +49/2366/32552 fax: +49/2366/104385 email: info@aquacare.de
EA_E_ACF.CDR	Version 1: 03.11.06 B. Ramsch	scale: - material: -

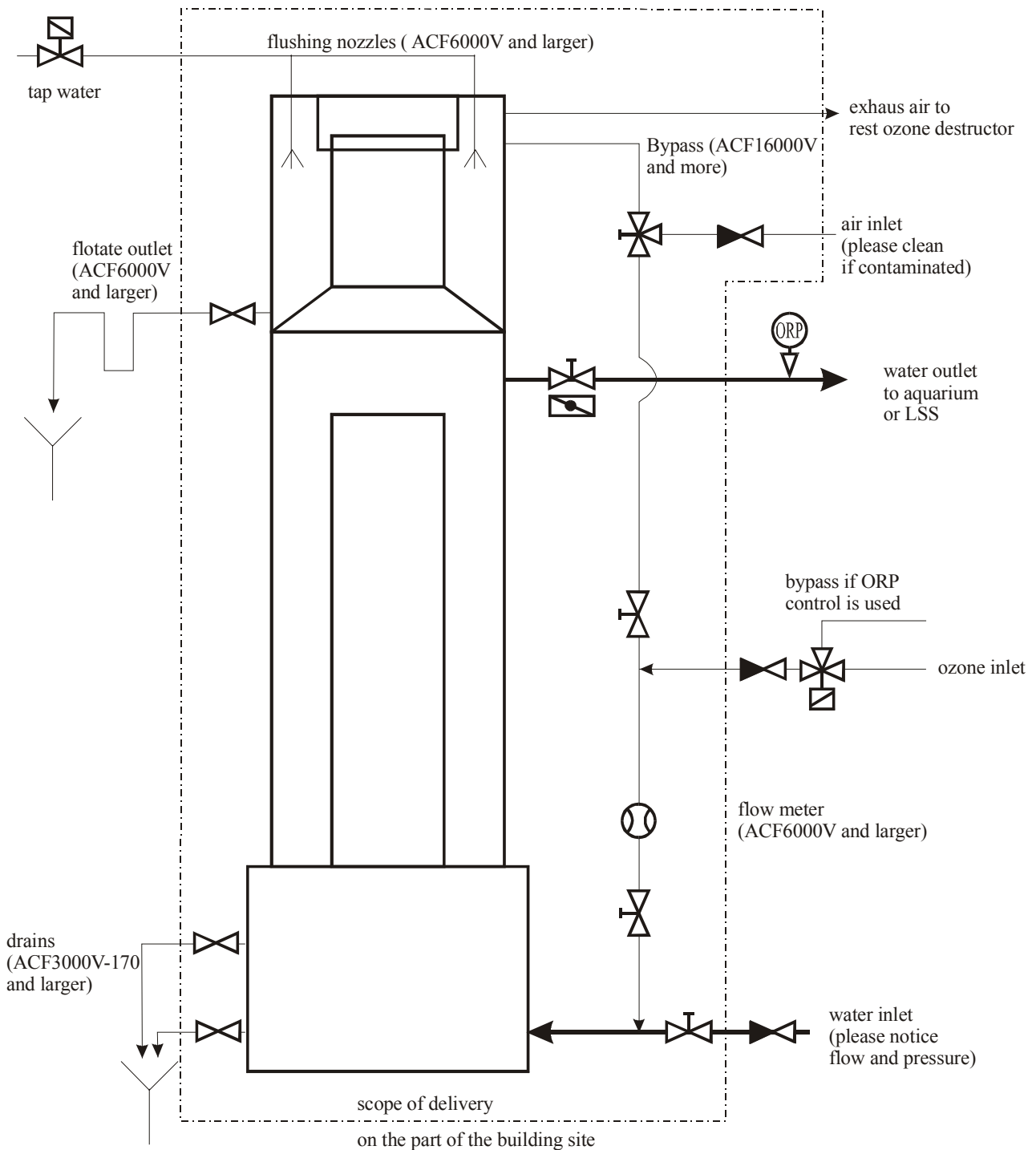

4.2. Basic equipment

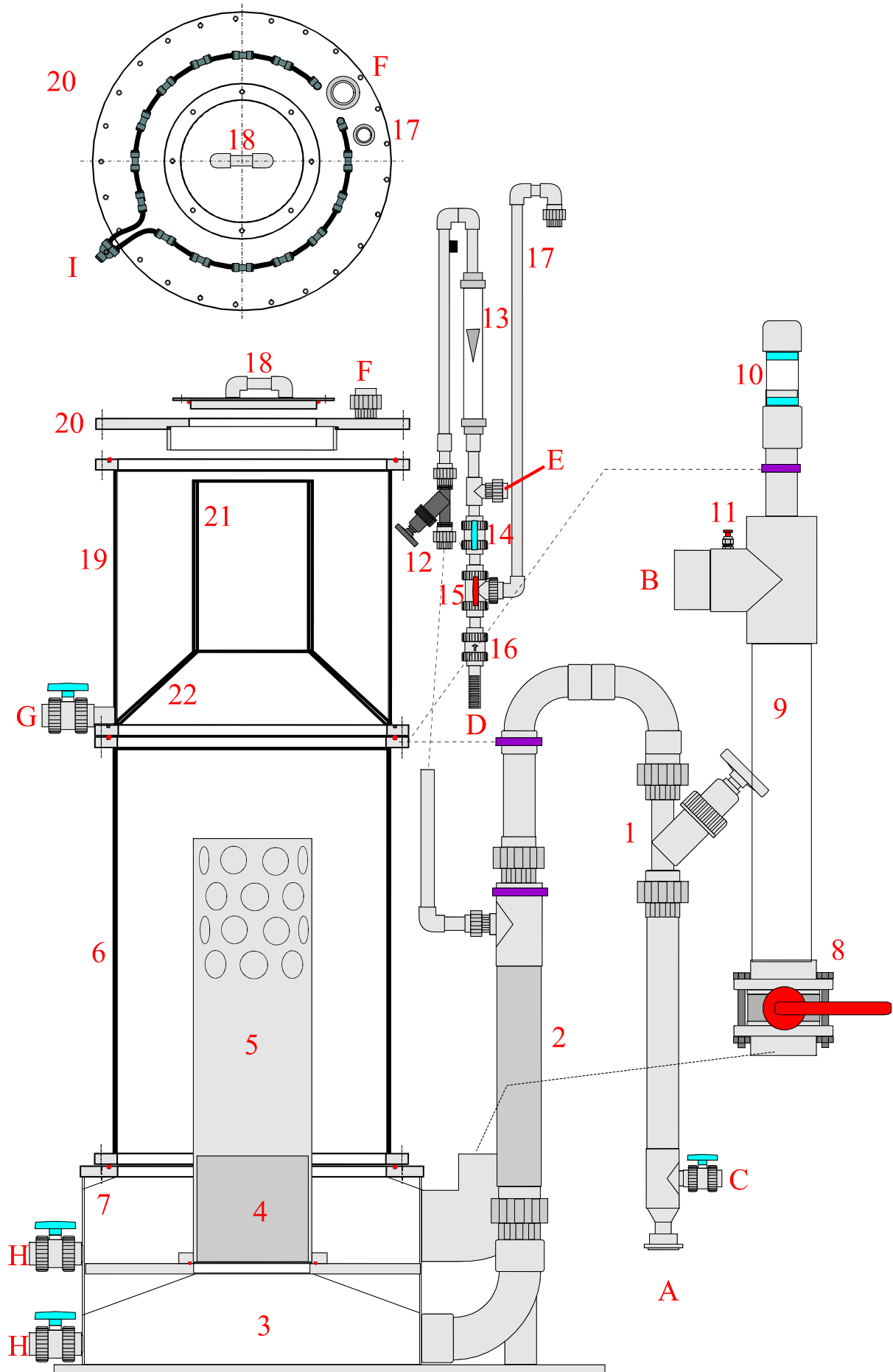

The skimmer is mounted on a rigid PVC plate and consists of:

1. water inlet regulating valve
 2. injector (Venturi)
 3. rotation chamber
 4. rotation breaker
 5. inner tube with distributing system
 6. main tube
 7. expanding cone
 8. water outlet ball valve / butterfly valve
 9. water outlet tube
 10. activated carbon for de-aerating
 11. ORP sensor connection
 12. air inlet regulating valve
 13. air flow meter
 14. air throttling valve
 15. 3/3 way valve for ozone recycling
 16. spring-loaded check valve
 17. tubing ozone recycling
 18. maintaining cap
 19. skimmer cup
 20. cap of skimmer cup
 21. contact tube
- A. water inlet (from aquarium);
B. water outlet (to aquarium);
C. auxiliary connection for e.g. AquaCare de-nitrifying filter
D. air inlet
E. ozone connector
F. air outlet
G. waste water outlet
H. drain
I. connector for flushing water

4.3. Options

As an option following parts may be installed:
inlet pump / injector pump;
water inlet flow meter (floating or electronic system);
ozone supply;
rest ozone destructor;
control for flushing nozzles;
activated carbon filter for air inlet;
automatic level control (PLC possible);
potential-free contacts for flow meters:

5. Principle of function

The aquarium water is pumped into the water inlet, will be enriched with air or and air-ozone mixture by an injector (2) and is pressed into the

deepest point of the unit – the rotation chamber (3). At this place is the maximum static pressure and so the gas exchange is most effective. The water-gas mixture ascends in the inner tube (5) and is evenly dispensed through the distribution system. In the main tube (6) the protein-containing foam is established. A part of the gas bubbles is drifted downwards the main tube (6). Because of the bigger diameter at the expanding cone (7) the water velocity gets lower and the bubbles are caught in the main tube and this extreme contact time enables a better protein binding at the bubbles. – The foam ascends the contact tube (21) into the cup (19). During this way the foam will be drained. In the cup only the firm foam with the waste products is collected. The waste air is leaving the cup through the air outlet (F). – The soaked air is regulated at the air inlet regulating valve (12) and its volume is displayed at the air flow meter (13). The skimmer is prepared for ozone consumption: if the air throttling valve (14) is reduced at the ozone input connector (E) is establish an under-inflation. So ozone containing air from the ozone generator is soaked. To enlarge the ozone efficiency a 3/3-way valve (15) may be switched to soak ozone containing waste air from the air outlet instead of the fresh air (D). So you can rise the ORP for some mV. – To prevent an unmeant ozone release a spring-loaded check valve (16) in the air inlet and an activated carbon filter (10) in the de-aeration tube of the water outlet are mounted.

6. Installation

6.1. Setting up



To guarantee a faultless operation of the filter the unit should be erected on an even and stable ground. Uneven parts of the floor must be flattened with floor pavement or a suitable base.



If the operation location is over 1000 meter above the sea level the motor must be larger dimensioned to protect it against overheating.

If sunlight reaches the main tube it should be covered with a black foil to prevent algae growth. This is not necessary with type “C” at an ORP over 700 mV.

6.2. Assembly of the skimmer



To prevent corrosion nearly all parts are made of plastic. So you must take care during transport, assembly and operation of the skimmer.

Large skimmers are delivered in three main parts: basis with rotation chamber (3) and expanding cone (7), main tube (6) and skimmer cup (19).



It is very important to screw the M10-plastic bolts with not more than **2 Nm** torque. If plexi-glas tubes are used (ACF6.000 and ACF16.000) do not exceed **1 Nm**. Higher forces may destroy screws, tapped holes and flanges.

1. Fix the inner tube (5) inside of the basis with screws and the o-ring. The inner tube should stand exactly vertical. With different torques at the screws you can adjust the tube.
2. Put the main tube (6) onto the basis. Do not forget the silicone seal (use a little bit of silicone fat) and turn the main tube that the bar for the de-aeration tube matches the de-aeration tube.
3. Now you can put the skimmer cup (19) onto the main tube. You can turn it as you wish. Then fix the cap (20) onto the cup.
4. The outlet tube with ball valve (8) or butterfly valve should be mounted next. Do not torque the bolts of the butterfly with more than 5 Nm.
5. In the end fix the injector (2) with the tubing to the rotation chamber.

6.3. Water connections

For operation the unit you must install the water connectors with the aquarium.



The connection with PVC-U must be glued only with approved adhesion. The processing regulation of the adhesion should be minded.

The water inlet (A) should be connected with the main pump, if not delivered (for water flow and pressure please look to "Technical data"). Otherwise connect the soaking tube (inlet) of the pump to the aquarium. This main pump is for the water

input and for producing air bubbles with the injector, too.

The water outlet (B) must flow without pressure. That means: the water must flow at least slightly downwards all the time. Do not use valves or tubes going upwards. Otherwise the skimmer will flow over.

At the auxiliary outlet (C) unit like chalk reactors, nitrate filter etc. may be connected. The connected units should need low water flows.

At the air inlet (D) instead of the PVC strainer an activated carbon may be connected. This is useful if there are substances in the air that should not diffuse into the process water (nicotine, organic diluter, etc.).

If you want to use ozone to enhance the efficiency of the skimmer and to increase the ORP of the aquarium water the ozone generator must be connected with the ozone inlet (E). If you do not use ozone this connector is not used.

If you do not use ozone the air outlet (F) should be connected with a tube going outside of the building to prevent high moisture in the rooms. If you use ozone the air outlet (F) must be connected implicitly with a rest-ozone destructor.



ozone is harmful to your health. Pay attention to all hints and laws for working with ozone.

Never close the air outlet (F).



The drain (G) of the skimmer cup (19) should be connected with the waste water systems. If you use ozone you must install a siphon to prevent ozone creeping into the rooms. If you use an automatically working flushing system for the skimmer cup the drain (G) may not be closed.

The connectors (H) are for draining the whole system. You can decide if you use it with hoses or if you connect them with the waste water system.

For flushing the skimmer cup you must connect a tap water line (minimum 2 bar) with the flushing water inlet (I). For automatic operation install a solenoid and a timer.

6.4. Electrical connection

The electrical connection must be done by authorized and qualified according with the local regulation only.



Before opening a terminal box and before every disassembling of electrical components the supply voltage must be disconnected at all phases (contact opening minimum 3 mm).

The electrical supply must be conform with the data at the rating plate. The filter and the pump must be protected with fuses.



It is useful to connect the motor of the pump with motor protection circuit-breaker to prevent damages.



If the power supply is not stable a voltage guard may be installed. If the phase are not stable a phases guard should be installed.



The rotation direction of the pump must be conform with the arrow at the pump body. If the pump runs in the wrong direction faults can occur. The change the direction of rotating two phase must be interchanged.

7. Start up the unit



Before start up the unit check out of all connections are done well. Make sure that all PVC-unions are tight and their o-ring seals are in the correct position.



Check out if the electrical connection is made correctly.

7.1. Filling up with water

Open all valve in the inlet water line of the skimmer to fill water into the pump.

Open the water outlet valve (8) and the air inlet regulating valve (12) totally.



The pump should never run without water. Make sure that the pump is filled with water. If a safe water supply is not sure install a run-dry protection circuit-breaker.

Close the inlet regulating valve (1) totally and open it with ONE turn.

Start the pump: the skimmer fills up with water. Verify if all flanges, unions and other connections are tight.

Open now the water inlet regulating valve (1) so far that the air bubbles will reach the lower part of the main tube (6) of the skimmer.

Before doing other adjustments let the skimmer run for minimum one day. In this time all water contact surfaces are covered with organic films and electrical charges are eliminated.

7.2. Adjusting the inlet water flow

The inlet water flow should not be too high. To less water is better than to much water. Adjust the water inlet in that way that the air bubbles reach the lower part of the main tube (6). Only in off-peak times the bubbles cannot reach the bottom.



It is very important that the water level inside the main tube is smooth. Strong turbulences and currents will destroy the fresh protein foam. If the water level is in motion reduce the inlet water valve.

7.3. Adjusting the water level inside of the skimmer

The water level inside of the skimmer is adjusted with the outlet water valve (8). The more you closed the valve the higher the water level. Normally the water level is few cm below the upper PVC flange of the main tube. In individual cases – if the water is polluted very strongly – the level must be lower.

The optimum water level creates inside the contact tube (21) of the cup (19) a solid dark foam. If the foam is very liquid the water level should be degraded by slightly opening of the water outlet valve (8).

If the skimmer spills over although the outlet valve (8) is fully opened, decrease the air let with the air inlet regulation valve (12), too.

7.4. Air and ozone volumes

Normally the air inlet flow is not reduced. Only with very high loaded water it is sometimes necessary to reduce the air inlet.

If the skimmer operates with ozone you must reduce the air throttling valve (14) in that way that ozone containing air reaches in the right volume the ozone inlet (D). For the right ozone flow please look into the manual of the ozone generator.

7.5. Ozone needs of the skimmer

It is not possible to define the ozone needs of a skimmer. There is one rule: the higher the organic loading the more ozone is required. Practical values are listed in chapter "technical data".



If the ozone generator is too small to get a high OR-potential the soaked fresh air through connector (D) can be changed to ozone containing exhaust air from the skimmer cup (19). Therefore you switch the 3/3-way valve (15) in that way that the air will be soaked through the tubing (17). Normally the ORP is raised about some mV.

To measure the ORP of the skimmer you can connect at the connector (11) an ORP sensor with 12 mm diameter. The ORP value of the outlet tube (B) is the same as the ORP inside of the skimmer main tube.

7.6. Flushing equipment of the skimmer

You can flush the skimmer cup (19) regularly by the use of flushing nozzles.

Depending on the quantity and quality of the foam the interval and flushing time should be varied. The below table gives a clue of that times.

	contamination		
	light	medium	strong
Flushing time	30 s	60 s	60 s
Interval time	10 min	5 min	2 min

7.7. Features of skimmer type „C“

The type "C" has an build-in cycling system, that means that the main part of the water will be soaked directly out of the skimmer. With this extreme long contact time it is possible to take out extreme pollution out of the water. In combination with ozone it is possible to kill all bacteria and you get sterile water. The type "C" is made e.g. for outlets of de-nitrifying filter with high organic and bacterial load and low flows.

The type "C" need perhaps an additional inlet pump – depending on the filter system structure. The type "C" should be filled with water manually to start up the system.

The type "C" is equipped with an water flow meter. Because of the normally high organic loads of the incoming water the flow meter is installed in the outlet of the skimmer. If you are varying the inlet flows you must take time to read the water flow because the system is reacting very slow.

8. Shut down the unit

To shut down the system please follow the above steps:

1. Shut down the ozone producing system.
2. After about 15 minutes stop the main circulation pump (and with type "C" the inlet pump, too). In the meantime the rest ozone will be blown out.
3. Close the ball valves at the inlet pump (normally main pump).
4. Stop the water supply of the flushing nozzles.
5. If the skimmer should be out of order for longer time drain it with the ball valve (H).

9. Maintain the unit

You do not need a lot of time to maintain the system. But for a long time operation without failures it is possible to do some steps.

9.1. Inlet pump / main pump



Principally every pump used in sea water tends to forming chalk crusts at rotors and other parts. Therefore the pump must be cleaned minimum once a year. Pay attention to the instruction manual of the pump. You get off chalk crusts with concentrated vinegar or diluted acids.



If you use acids wear the prescribed protective clothing and pay attention to the common regulation dealing with chemicals.

Depending on carbonate hardness (alkalinity), calcium and magnesium concentration of the aquarium water the pumps and other parts of the tubing may calcify more or less fast. Therefore inspect the pump after 3 months operation the first time.



Adjust the motor protection circuit-breaker in that way, that it will not trigger just yet. If chalk crusts are formed inside the pump the circuit-breaker triggers. This is a signal to maintain the pump.

9.2. Injector

AquaCare uses exclusively high-end injectors – you can see the extreme dimensions compared to others. Therefore the injector will never calcify.

But with the time salt can block the air inlet of the injector. If the air volume sinks below the normal operation limit (see chapter “technical data”) you can flush them away by soaking reverse osmosis water through the air inlet (D).

9.3. Skimmer cup / flushing nozzles

The produced foam is flushed regularly by the automatic flushing system (if installed) into the waste water system. But contact tube (21) and foam cone (22) must be cleaned manually. Deposits of fatty substances will hinder with the time the efficiency of the skimmer. Flushing systems for the contact tube are not working very well because they will flush back the fatty debris into the process water. The back-flushed substances cannot be skimmed again.

For cleaning the skimmer cup shut down the unit as described above. Unfasten the plastic screws and take off the cap (20) of size 6,000 and 16,000 respectively the maintaining cap (18) of size 30,000 and larger. Take away the debris by using soft brushes and paper sheets.

If the flushing nozzles inside the cap are not working properly (wear of ozone driven units is larger) you must replace them. Screw the old one out counter clockwise. Screw the new nozzles into the cap clockwise – do not use tools, because the threads of the nozzles are very sensitive to high torques.

9.4. Main tube

Normally the main tube stays clean for a very long time. If sunlight falls to the main tube it should be wrapped with black foil to prevent algae growth. Especially coralline algae causes scratches during the cleaning process.

10. Trouble shooting

If you cannot eliminate the disturbance ask your service partner or AquaCare.

10.1. The air flow is diminishing

The injector may be blocked by salt crusts. Clean it, see chapter “maintenance: injector”.

10.2. The skimmer does not produce foam

There are several reasons for not producing foam.

1. The concentration of skimmable substances is too low: The skimmer will start again, if organic substances are in the water again, e.g. after feeding the animals. Biological systems have cycles with more or less organic loading.
2. The water level inside the main tube is too low: throttle the out let valve (8) a little bit.
3. There is too much water coming into the skimmer and causes strong currents inside the upper part of the main tube (6): reduce the inlet by throttling the water inlet regulating valve (1).

4. There are foam forming inhibitors in the water, e.g. vitamin E, fats (too fatty food) and other substances: try to identify the substance and stop or reduce the contamination.

10.3. The skimmer produces too much and too wet foam / the skimmer foams over

There are too much skimmable substances in the water, e.g. water treatment substances, some trace element solutions, vitamins: try to find out the substance and reduce the input into the system.

Lower the water level by slightly opening the outlet valve (8) and/or throttling the air inlet regulating valve (12).

10.4. The air bubbles do not reach the basis / expanding cone

To realize extreme long contact times the air bubbles should reach the lower part of the main tube (6).

1. There are too less skimmable substances in the water: do not change the adjustments. The skimmer is working in the low concentration mode.
2. The inlet water flow is too less: enhance the inlet air flow by opening the water inlet regulating valve (1). But take care not to produce currents in the upper part of the main tube.

11. Warranty

You have 24 months warranty on all AquaCare units excepts spare parts like pump bearings and rotors. You have no warranty if parts are broken by violent (for example totally closed water inlet). For consequential losses AquaCare is not liable.

12. Technical Data

<i>AquaCareFlotor size</i>	6000V	16000V	30000V	50.000 V	70000V	110000V	170.000 V	240.000 V	480.000 V	630.000 V
Order number	354-020	354-030	354-040	354-050	354-065	354-080	354-100	354-120	354-120	354-190
Water flow, ca. m ³ /h	4	11	20	33	50	75	110	160	330	420
Water flow type „C“, ca. m ³ /h	0.6	1.6	3	5	7	11	17	24	48	63
Air flow, ca. m ³ /h	1.3	3.6	7	11	16	25	35	53	110	140
Ozone needs*, g/h	0.12...0.6	0.32...1.6	0.6...3.0	1.0...5.0	1.5...7.7	2.2...11.0	3.5...17.5	4.7...23.5	10...50	12...63
Ozone needs* Typ „C“, ca. g/h	5	13	25	40	65	90	150	200	420	530
Height with cup, m	1.8	2.0	2.1	2.3	2.4	2.8	3.1	3.9	4.7	4.9
Footprint size L×B, mm	600×400	750×500	950×600	1,100×800	1,300×900	1,500×1,100	1,800×1,400	2,100×1,600	2,900×2,100	3,100×2,350
Diameter main tube, mm	200	300	400	550	650	800	1,000	1,200	1,700	1,900
Water volume, m ³	0.05	0.12	0.17	0.41	0.58	1.2	2.2	3.2	9.5	13.5
Contact time water, min	0.8	0.7	0.5	0.8	0.7	1.0	1.4	1.2	1.7	1.9
Contact time air, min	larger than 10									
Material main tube	PMMA (Plexiglas)		PVC transparent			PE HWST black (with man hole)				
Material cup	PMMA (Plexiglas)		PVC transparent			PVC transparent (PE on request)				
Material basis	PVC grey					PE HWST black				
Material flange sealing	NBR 70		silikone 60							
Material flange screws	polyamid (corrosion free)					Stainless steel				
Inlet injector	d40, DN30	d50, DN40	d63, DN50	d63, DN50	d75, DN65	d90, DN85	d125, DN110	d140, DN125	d200, DN180	d280, DN250
Outlet skimmer	d75, DN65	d90, DN85	d126, DN110	d125, DN110	d140, DN125	d160, DN150	d200, DN180	d225, DN200	d315, DN300	d315, DN300
Height outlet, m	1,1	1,1	1,1	1,1	1,1	1,5	1,7	1,8	2,1	2,3
Connection drain of cup	d20, DN15	d20, DN15	d40, DN32	d40, DN32	d40, DN32	d50, DN40	d50, DN40	d63, DN50	d63, DN50	d63, DN50
Connection drain basis (×2)	d20, DN15	d20, DN15	d25, DN20	d32, DN25	d40, DN32	d50, DN40	d50, DN40	d50, DN40	d50, DN40	d50, DN40
Connection air	d25, DN20	d32, DN25	d40, DN32	d40, DN32	d50, DN40	d63, DN50	d75, DN65	d90, DN85	d125, DN110	d140, DN125
Connection ozone	d20, DN15	d20, DN15	d25, DN20	d25, DN20	d32, DN25	d32, DN25	d40, DN32	d40, DN32	d50, DN40	d63, DN50
Numbers of flushing nozzles	6	8	12	14	16	18	20	32	46	52
Flushing flow at 4 bar, m ³ /h	0.18	0.24	0.36	0.42	0.48	0.54	0.60	0.96	1.38	1.56
Connection flushing water	d10 (PE pressure tube)									
Operation temperature	2...35°C									
Weight empty, kg	45	52	95	130	180	260	430	520	600	700
Weight operation, t	0.1	0.17	0.27	0.44	0.76	1.46	2.63	3.72	10.1	14.2
min. feed water, m ³ /h (bar)	4 (1.2)	11 (1.2)	20 (2.0)	33 (2.0)	50 (2.0)	75 (2.0)	110 (2.0)	160 (2.0)	330 (2.0)	420 (2.0)
Suitable pump (Iwaki)	MX400	MX401	MX403	MDM40-150	MDM40-150	MDM50-150	MDE125-220	MDE125-240		2×MDE125-250
Power of pumpe, kW	0.37	0.75	2.2	5.5	5.5	11	11	15		
Weight of pump, kg	12	14	24	105	105	105	360	380		
Connection inlet pump	1½"	1½"	2"	Flange d90	Flange d90	Flange d90	Flange d140	Flange d140		
Connection outlet Pump	1½"	1½"	1½"	Flange d50	Flange d50	Flange d63	Flange d110	Flange d110		

* Ozone need is extremely dependend of organic load of the water. The need for type "C" is given for sterile outlet water (about 700 mV).

13. Protocol

Kundennr. / customer no.: Tel./phone: Fax: Email: Kom.	 <p style="font-size: small;">www.aquacare.de </p> <p style="font-size: x-small;">AquaCare GmbH & Co. KG Am Wiesenbusch 11 · D-45966 Gladbeck · Germany Tel.: +49 / 2043 / 375758-0 · Fax: +49 / 2043 / 375758-90 www.aquacare.de · info@aquacare.de</p>	
Anlagentyp / Type of unit	ACF	
Anlagennr./unit no.	2-2011-000	
Hauptpumpe / main pump	Magnetisch gekoppelte Kreislumppe / magnetic coupled circulation pump	
Hersteller / manufacturer	IWAKI	
Typ / type	MX400CV5E	
Nr. / No.		
minimale Fördermenge / minimum flow	m ³ /h	
Motor:		
Hersteller / manufacturer, Nr. / No.		
Anschluss / electrical connection, No.		
Steuerung / control:		
Hersteller / manufacture	maj	
Einstellungen im Auslieferungszustand / parameter in delivery condition	Spülzeit / flushing time: 1 min; Spülintervall / flushing interval: 1 h	
Ventile / valves	Sibo ball valve, Sibobutterfly valve	
Betriebstest / running test:	Testbedingungen / test conditions	Normleistung / normal conditions
Elektrische Daten / electrical data:		
Spannung / voltage L1-L2	390 V	400 V ± 10%
dito L1-L3	390 V	.
dito L2-L3	391 V	.
dito L1-N	221 V	230 V ± 10%
dito L2-N	228 V	.
dito L3-N	225 V	.
Strom / current L1	24,0 A	0 A
Strom / current L2	24,3 A	.
Strom / current L3	23,5 A	.
Strom / N	0,52 A	0,8 A
Betriebstest / running test # 2009-0067:	test conditions	normal conditions
Water flow	20,0 m ³ /h ±0,2%	20 m³/h
Air flow	7,2...8,0 m ³ /h	7 m³/h
Test period	2 h	

Datum / date: 03.09.2009

AquaCare: Herr B. Ramsch

Kunde / customer:

Unterschrift / signature:

14. Appendix: CE Declaration of conformity

Declaration of conformity in accordance with EMC directive

The company:
AquaCare GmbH & Co. KG
Josefstraße 35-37
D-45699 Herten, Germany

declares, that the product

Skimmer AquaCareFlotor

comply with directive
98/37/EEC and
2001/95/EEC
of the European Community.

Gladbeck, 01.07.2011

AquaCare GmbH & Co. KG
* Aquatic Systems Research *
INNOVA-Park, Am Wiesenbusch 11
Tel.: 02043-375758-0 Fax: 375758-90
email: info@aquacare.de
D-45966 Gladbeck



15. Appendix: switch board

16. Appendix: pump

17. Appendix: motor

18. Appendix: ozone generator

19. Appendix: ozone destructor